

WHELEN[®]

ENGINEERING COMPANY INC.

51 Winthrop Road
Chester, Connecticut 06412-0684
Phone: (860) 526-9504
Fax: (860) 526-4078
Internet: www.whelen.com
Sales e-mail: autosale@whelen.com
Canadian Sales e-mail: canadiansales@whelen.com
Customer Service e-mail: custserv@whelen.com

Installation Guide: Universal LED Hide-A-Way

Safety First

This document provides all the necessary information to allow your Whelen product to be properly and safely installed. Before beginning the installation and/or operation of your new product, the installation technician and operator must read this manual completely. Important information is contained herein that could prevent serious injury or damage.

- **Proper installation of this product requires the installer to have a good understanding of automotive electronics, systems and procedures.**
- **If mounting this product requires drilling holes, the installer MUST be sure that no vehicle components or other vital parts could be damaged by the drilling process. Check both sides of the mounting surface before drilling begins. Also de-burr any holes and remove any metal shards or remnants. Install grommets into all wire passage holes.**
- **If this manual states that this product may be mounted with suction cups, magnets, tape or Velcro[®], clean the mounting surface with a 50/50 mix of isopropyl alcohol and water and dry thoroughly.**
- **Do not install this product or route any wires in the deployment area of your air bag. Equipment mounted or located in the air bag deployment area will damage or reduce the effectiveness of the air bag, or become a projectile that could cause serious personal injury or death. Refer to your vehicle owner's manual for the air bag deployment area. The User/Installer assumes full responsibility to determine proper mounting location, based on providing ultimate safety to all passengers inside the vehicle.**
- **For this product to operate at optimum efficiency, a good electrical connection to chassis ground must be made. The recommended procedure requires the product ground wire to be connected directly to the NEGATIVE (-) battery post.**
- **If this product uses a remote device to activate or control this product, make sure that this control is located in an area that allows both the vehicle and the control to be operated safely in any driving condition.**
- **Do not attempt to activate or control this device in a hazardous driving situation.**
- **This product contains either strobe light(s), halogen light(s), high-intensity LEDs or a combination of these lights. Do not stare directly into these lights. Momentary blindness and/or eye damage could result.**
- **Use only soap and water to clean the outer lens. Use of other chemicals could result in premature lens cracking (crazing) and discoloration. Lenses in this condition have significantly reduced effectiveness and should be replaced immediately. Inspect and operate this product regularly to confirm its proper operation and mounting condition. Do not use a pressure washer to clean this product.**
- **It is recommended that these instructions be stored in a safe place and referred to when performing maintenance and/or reinstallation of this product.**
- **FAILURE TO FOLLOW THESE SAFETY PRECAUTIONS AND INSTRUCTIONS COULD RESULT IN DAMAGE TO THE PRODUCT OR VEHICLE AND/OR SERIOUS INJURY TO YOU AND YOUR PASSENGERS!**

For warranty information regarding this product, visit www.whelen.com/warranty

Installation:

Installation of Universal LED Hide-A-Way into a composite automotive headlight or taillight assembly:

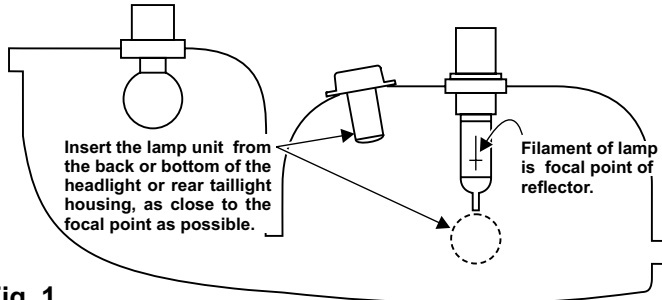

Fig. 1

Top view of automotive composite headlight or taillight housing assembly.

1. Follow manufacturers instructions to remove the headlight (or taillight) reflector assembly from the vehicle.
2. Select the mounting location for the LED Hide-A-Way, keeping in mind the following:
 - The LED Hide-A-Way will share the same reflector as the headlight, brake light, or signal light. Make sure the Hide-A-Way does not interfere with the operation of these lights.
 - There must be a minimum of one inch of space between the LED Hide-A-Way and the lens.
 - The LED Hide-A-Way must not be installed above the horizontal centerline of the reflector.
 - The LED Hide-A-Way must not be installed above any OEM supplied light.

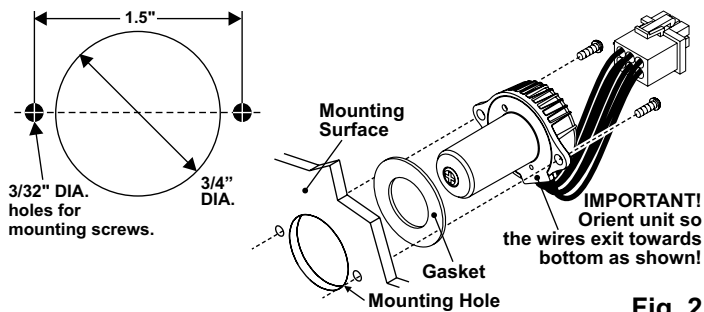

Fig. 2

3. Choose a surface in the rear or bottom of the housing which is as flat as possible. Using a hole saw, cut a 3/4" hole in the housing as shown (Fig. 1 & 2) and de-burr the hole.
4. Insert the LED lamp assembly into the reflector housing. Mark the location for the two mounting holes (3/32" DIA.). Remove the lamp assembly and drill the holes.
5. Install the lamp assembly and gasket using the two provided #6 sheet metal screws and secure the lamp to the reflector assembly.
6. Repeat steps 1 thru 6 for the other side of the vehicle.
7. Remount both headlight assemblies to the vehicle and route the connector cable from the Hide-A-Way to the LED driver module.
8. The module should be mounted in the engine compartment near the vehicle headlight circuit. Do not mount the module onto the engine or close to the exhaust system.

IMPORTANT NOTE: If the LED Hide-A-Way is being used in an area previously occupied by an S30HA light assembly, it is important to seal the mounting holes used by the previous assembly with RTV or other suitable material.

NOTE: Whelen® LED Hide-A-Way systems are designed to interface with the Whelen® LED driver module. Do not connect the Whelen LED Hide-A-Way lamp directly to a battery or to a standard flasher. LED damage will result and void warranty. Detailed wiring, switching and installation instructions are enclosed with this unit.

WARNING! All customer supplied wires that connect to the positive terminal of the battery must be sized to supply at least 125% of the maximum operating current and **FUSED** at the battery to carry that load. **DO NOT USE CIRCUIT BREAKERS WITH THIS PRODUCT!**

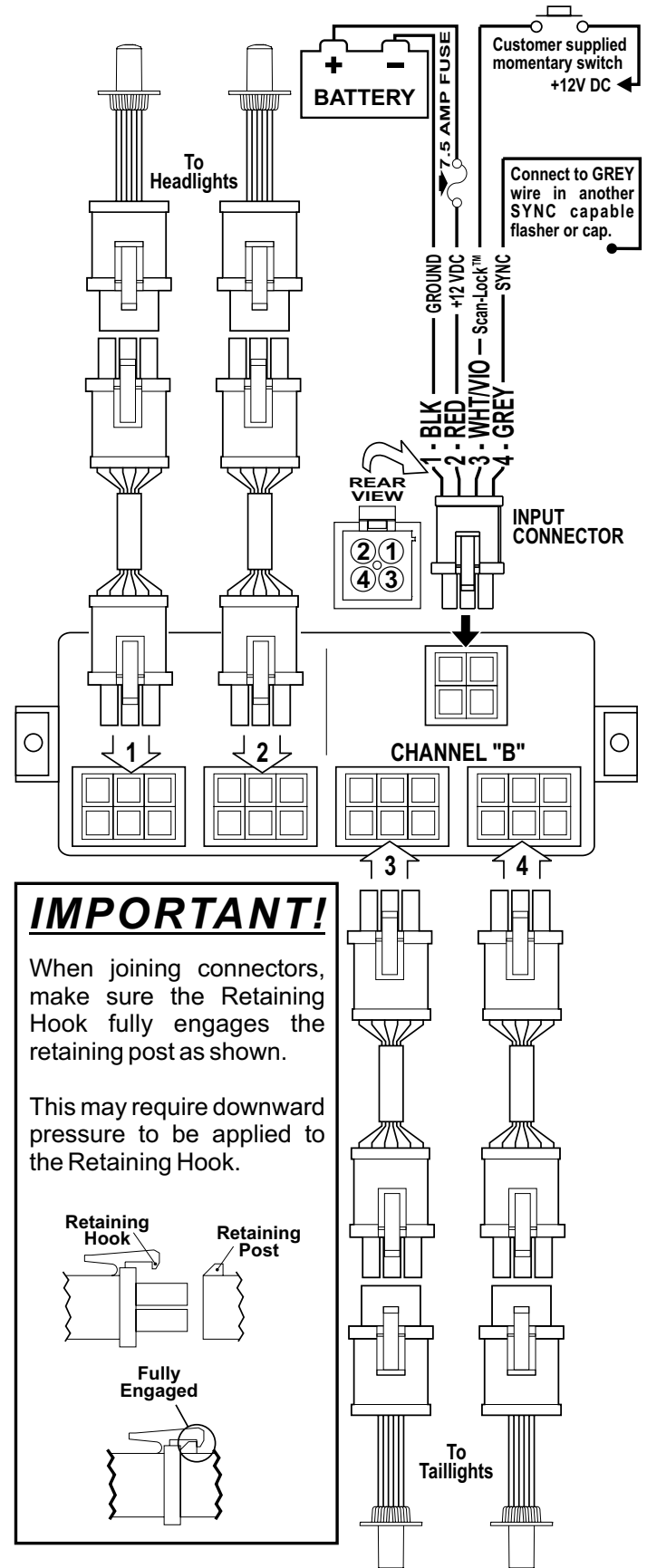

IMPORTANT WARNING!

CAUTION! DO NOT LOOK DIRECTLY AT THESE LEDS WHILE THEY ARE ON. MOMENTARY BLINDNESS AND/OR EYE DAMAGE COULD RESULT!

Wiring & Operation:

The LED driver module is powered & controlled by the 4 wires coming from the Input Connector. Locate the input connector and plug it into the LED driver module.

RED: Positive / Extend the RED wire to a 12 volt DC power source (Fuse @ 7.5 amps)

BLACK: Ground / Extend the BLACK wire to the negative terminal of the battery.

GRAY: SYNC / Connect the GREY wire to other SYNC capable power supplies to synchronize their output. Cap off the wire if not used.

WHITE/VIOLET: Scan-Lock™ / Flash pattern selection. Extend the WHT/VIO wire to a customer supplied momentary switch (Fuse @ 1 amp). See Scan-Lock section for operation.

IMPORTANT WARNING: DO NOT ATTEMPT TO USE THE LED LIGHT-HEAD(S) WITHOUT THE LED DRIVER MODULE CONNECTED.

Scan-Lock™ (WHITE/VIOLET)

In order to program flash patterns, the lighthouse must be on. With the appropriate lighthouse(s) activated:

TO CHANGE PATTERNS: To cycle forward to the next available pattern apply +12 volts to the WHT/VIO wire for less than 1 second and release.

To cycle back to the previous pattern apply +12 volts to the WHT/VIO wire for more than 1 second and release.

TO CHANGE THE DEFAULT PATTERN: When the desired pattern is displayed, allow it to run for more than 5 seconds. The lighthouse will now display this pattern when initially activated.

TO RESTORE THE FACTORY DEFAULT PATTERN: This will reset all patterns back to there default settings. Disconnect main power and apply power to the WHT/VIO wire. With power applied to the WHT/VIO wire, turn main power back on. Allow the unit to run for 3 seconds then remove power from the WHT/VIO wire.

A Normally Open momentary switch should be used to control Scan-Lock operation.

Flash Patterns -

The following is a list of all the available flash patterns and their respective stages:

Pattern	Stage(s)	Pattern	Stage(s)
1. SignalAlert™ 75 *	1>2>3>4	18. SignalAlert™ 75 *	5
2. CometFlash® 75 *	1>2>3>4	19. CometFlash® 75 *	5
3. DoubleFlash 75 *	1>2>3>4	20. DoubleFlash 75 *	5
4. SingleFlash 75 *	1>2>3>4	21. SingleFlash 75 *	5
5. ComAlert™ 75 *	1>2>3>4	22. ComAlert™ 75 *	5
6. LongBurst™ 75 *	1>2>3>4	23. LongBurst™ 75 *	5
7. PingPong™ 75 *	1>2>3>4	24. PingPong™ 75 *	5
8. SingleFlash 60	1>2>3>4	25. SingleFlash 60	5
9. SingleFlash 90	1>2>3>4	26. SingleFlash 90	5
10. SingleFlash 120	1>2>3>4	27. SingleFlash 120	5
11. SingleFlash 300	1>2>3>4	28. SingleFlash 300	5
12. DoubleFlash 150	1>2>3>4	29. DoubleFlash 150	5
13. ComAlert™ 150	1>2>3>4	30. ComAlert™ 150	5
14. ActionFlash™ 50	1>2>3>4	31. ActionFlash™ 50	5
15. ActionFlash™ 150	1>2>3>4	32. ActionFlash™ 150	5
16. ModuFlash™	1>2>3>4	33. ModuFlash™	5
17. ActionScan™	1>2>3>4	34. ActionScan™	5

* = SYNC Pattern

The first half of the patterns are available in Stages 1 thru 4, while the second half are available in Stage 5 only. To better understand how the Stage of a pattern effects its appearance, refer to the following diagram.

REMEMBER! Phase 1 always alternates with Phase 2!

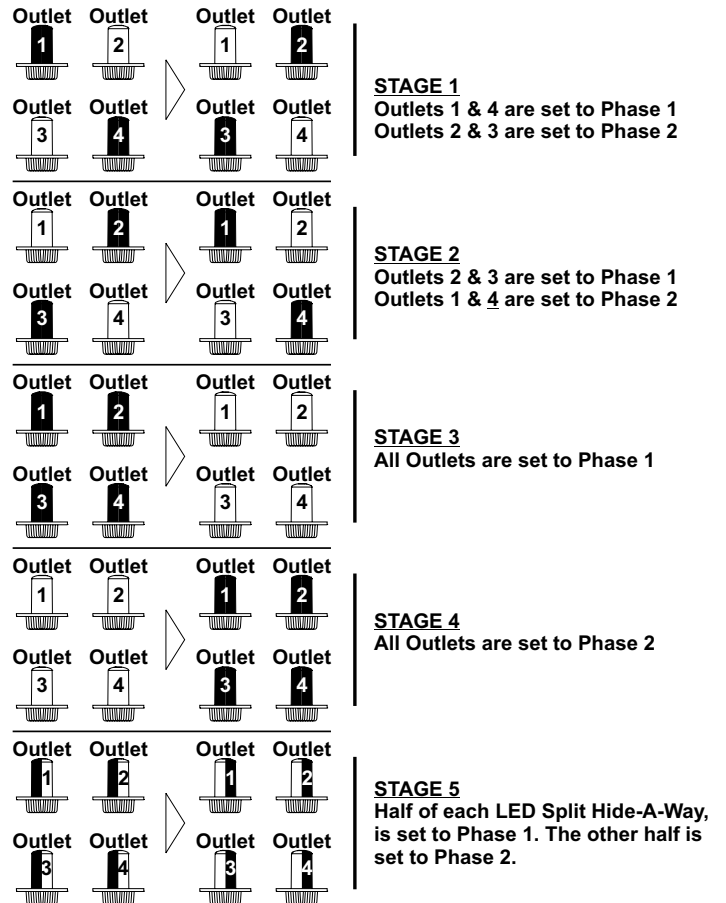

IMPORTANT! Before returning this vehicle to active service, visually confirm the proper operation of this product, as well as all vehicle components and equipment.