

WHELEN®

ENGINEERING COMPANY INC.

Route 145, Winthrop Road,
Chester, Connecticut 06412

Phone: (860) 526-9504

Fax: (860) 526-4078

Internet: www.whelen.com

Sales e-mail: autosale@whelen.com

Canadian Sales e-mail: autocan@whelen.com

Customer Service e-mail: custserv@whelen.com

Installation Guide Remote9 Interconnect Cable

If your control head is model:

WS295HFS4 or PCCS9N

1. Locate the Aux enable line from your remote head.
2. Strip approx. 1/2" of insulation off the end of this wire.
3. Crimp the supplied AMP™ pin securely onto the end of this wire.
4. Locate the 4-position pin housing on your remote9 interconnect cable.
5. Insert the newly pinned, aux enable wire into position 3 of the pin housing.

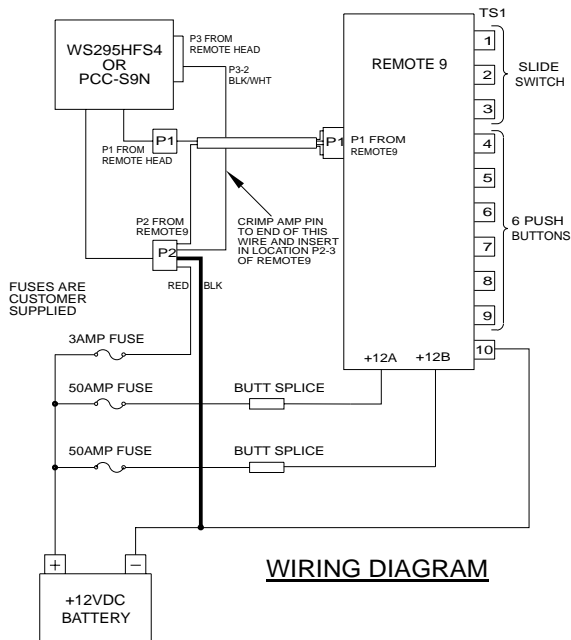

If your control head is model:

WS295HFS5 or WS295HFS5A

1. Using the White with Red stripe wire included with your interconnect cable, insert the pre pinned end into position 3 of the 4-position pin housing on your remote9 interconnect cable.
2. To maintain constant, back-lit control head illumination, connect the White w/Red wire to key-switched +12 VDC.
3. To enable variable intensity, back-lit control head illumination, connect the White w/Red wire to your vehicle's dashboard dimmer control switch.

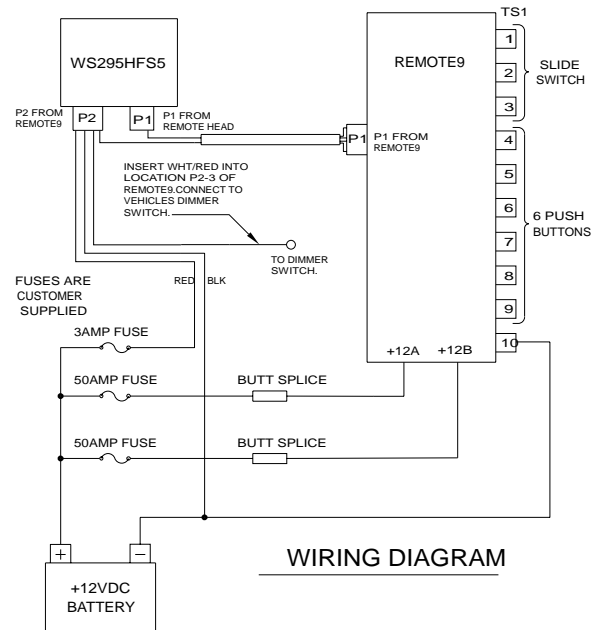

Automotive: Other