

WHELEN[®]

ENGINEERING COMPANY INC.

Route 145, Winthrop Road,

Chester, Connecticut 06412

Phone: (860) 526-9504

Fax: (860) 526-4078

Internet: www.whelen.com

Sales e-mail: autosale@whelen.com

Canadian Sales e-mail: autocan@whelen.com

Customer Service e-mail: custserv@whelen.com

Installation Guide 5000 Plus Gasket Retro-Fit Kit

Safety First

This document provides all the necessary information to allow your Whelen product to be properly and safely installed. Before beginning the installation and/or operation of your new product, the installation technician and operator must read this manual completely. Important information is contained herein that could prevent serious injury or damage.

- **Proper installation of this product requires the installer to have a good understanding of automotive electronics, systems and procedures.**
- **If mounting this product requires drilling holes, the installer MUST be sure that no vehicle components or other vital parts could be damaged by the drilling process. Check both sides of the mounting surface before drilling begins. Also de-burr any holes and remove any metal shards or remnants. Install grommets into all wire passage holes.**
- **If this product is mounted with tape or Velcro™, clean the mounting surface with a 50/50 mix of isopropyl alcohol and water and dry thoroughly.**
- **Do not install this product or route any wires in the deployment area of your air bag. Equipment mounted or located in the air bag deployment area will damage or reduce the effectiveness of the air bag, or become a projectile that could cause serious personal injury or death. Refer to your vehicle owners manual for the air bag deployment area. The User/Installer assumes full responsibility to determine proper mounting location, based on providing ultimate safety to all passengers inside the vehicle.**
- **For this product to operate at optimum efficiency, a good electrical connection to chassis ground must be made. The recommended procedure requires the product ground wire to be connected directly to the NEGATIVE (-) battery post.**
- **If this product uses a remote device to activate or control this product, make sure that this control is located in an area that allows both the vehicle and the control to be operated safely in any driving condition.**
- **Do not attempt to activate or control this device in a hazardous driving situation.**
- **This product contains either strobe light(s), halogen light(s), high-intensity LEDs or a combination of these lights. Do not stare directly into these lights. Momentary blindness and/or eye damage could result.**
- **Use only soap and water to clean the outer lens. Use of other chemicals could result in premature lens cracking (crazing) and discoloration. Lenses in this condition have significantly reduced effectiveness and should be replaced immediately. Inspect and operate this product regularly to confirm its proper operation and mounting condition. Do not use a pressure washer to clean this product.**
- **It is recommended that these instructions be stored in a safe place and referred to when performing maintenance and/or reinstallation of this product.**
- **FAILURE TO FOLLOW THESE SAFETY PRECAUTIONS AND INSTRUCTIONS COULD RESULT IN DAMAGE TO THE PRODUCT OR VEHICLE AND/OR SERIOUS INJURY TO YOU AND YOUR PASSENGERS!**

ATTENTION! The contents of this kit will vary, depending on the serial number of the lightbar you own and whether or not you have added any new lens' to replace the original factory lens'. Only those lightbars whose serial numbers are from 244 through 312 will be receiving two, new lens'. If your lightbar's serial number does not fall into this area but has had replacement lens' installed during the month of November, 1994, through the month of March, 1995 contact your Whelen representative to receive the correct replacement lens' designed for this kit.

Retro-Fit Procedure:

Note: Remove endcaps, lens' and lens dividers before proceeding with this retro-fit.

Lens Divider Gaskets (Fig. 1)

1. Remove the existing gaskets from the lens dividers.
2. Using a file (or other suitable device), remove the molded points shown in Fig.1.
3. Position the new divider gasket loosely onto the lens divider.
4. Align Groove "A" on the new gasket with Tongue "A" on the lens divider and press the new gasket into the lens divider as shown in the illustration below.
5. Now using Groove "B" and Tongue "B", repeat the procedure shown in step 4. Again, press the new gasket into the lens divider as shown in the illustration below.
6. With both hands, simultaneously press the gasket into the lens divider from Tongues "A" & "B" towards the middle of the divider.

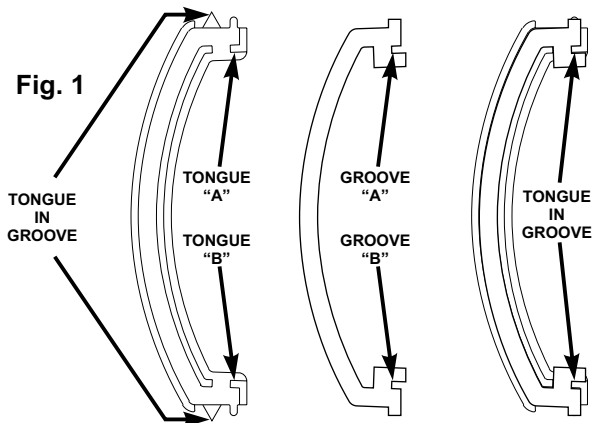

Extrusion Gasket (Fig. 2)

1. Position the extrusion gasket along the bottom of the extrusion so it is flush with the leading edge of the extrusion. Do not stretch or cut this gasket!
2. Once the precise mounting location has been determined, the adhesive backing can now be removed.
3. Re-position the gasket in it's mounting location and press firmly. Repeat procedure for the upper side of the extrusion

Extrusion Plug (Fig. 2)

1. Apply silicone (user supplied) to the carriage bolt opening in the extrusion. Insert the Extrusion Plug into the extrusion as shown.

Re-Assembly

1. You must spread the extrusion apart to slide the lens' into their positions. Failure to do so will cause the extrusion gaskets to "roll" and will result in gasket failure and leakage.
2. If your lightbar has or will receive the new lens', contact Whelen Technical Support for proper installation, based on your specific lightbar. Be sure to have your serial number ready when you call.

Retro-Fit Kit Parts List (P/N# 01-0416281-00)

<u>QTY</u>	<u>DESCRIPTION</u>	<u>PART NUMBER</u>
16	DIVIDER GASKETS	38-0141721-00C
2	EXTRUSION PLUGS	38-0221868-00C
2	EXTRUSION GASKETS	38-0316271-01C

Fig. 2

