

WHELEN[®]

ENGINEERING COMPANY INC.

51 Winthrop Road
Chester, Connecticut 06412-0684
Phone: (860) 526-9504
Fax: (860) 525-4078
Internet: www.whelen.com
Sales e-mail: autosale@whelen.com
Canadian Sales e-mail: autocan@whelen.com
Customer Service e-mail: custserv@whelen.com

Installation Guide BL627 Siren Amplifier

Safety First

This document provides all the necessary information to allow your Whelen product to be properly and safely installed. Before beginning the installation and/or operation of your new product, the installation technician and operator must read this manual completely. Important information is contained herein that could prevent serious injury or damage.

- **Proper installation of this product requires the installer to have a good understanding of automotive electronics, systems and procedures.**
- **If mounting this product requires drilling holes, the installer MUST be sure that no vehicle components or other vital parts could be damaged by the drilling process. Check both sides of the mounting surface before drilling begins. Also de-burr any holes and remove any metal shards or remnants. Install grommets into all wire passage holes.**
- **If this manual states that this product may be mounted with suction cups, magnets, tape or Velcro®, clean the mounting surface with a 50/50 mix of isopropyl alcohol and water and dry thoroughly.**
- **Do not install this product or route any wires in the deployment area of your air bag. Equipment mounted or located in the air bag deployment area will damage or reduce the effectiveness of the air bag, or become a projectile that could cause serious personal injury or death. Refer to your vehicle owner's manual for the air bag deployment area. The User/Installer assumes full responsibility to determine proper mounting location, based on providing ultimate safety to all passengers inside the vehicle.**
- **For this product to operate at optimum efficiency, a good electrical connection to chassis ground must be made. The recommended procedure requires the product ground wire to be connected directly to the NEGATIVE (-) battery post.**
- **If this product uses a remote device to activate or control this product, make sure that this device is located in an area that allows both the vehicle and the device to be operated safely in any driving condition.**
- **Do not attempt to activate or control this device in a hazardous driving situation.**
- **If this product contains strobe light(s), halogen light(s) or high-intensity LEDs, do not stare directly into these lights. Momentary blindness and/or eye damage could result.**
- **Use only soap and water to clean the outer lens. Use of other chemicals could result in premature lens cracking (crazing) and discoloration. Lenses in this condition have significantly reduced effectiveness and should be replaced immediately. Inspect and operate this product regularly to confirm its proper operation and mounting condition. Do not use a pressure washer to clean this product.**
- **It is recommended that these instructions be stored in a safe place and referred to when performing maintenance and/or reinstallation of this product.**
- **FAILURE TO FOLLOW THESE SAFETY PRECAUTIONS AND INSTRUCTIONS COULD RESULT IN DAMAGE TO THE PRODUCT OR VEHICLE AND/OR SERIOUS INJURY TO YOU AND YOUR PASSENGERS!**

For warranty information regarding this product, visit www.whelen.com/warranty

IMPORTANT!!!

Be sure to not only read this entire manual but also SAVE this and all Serial Communication manuals. They contain important data that may need to be referenced in the future. Consider storing these manuals in a 3-ring binder for easy referencing.

Please note that the installation procedure outlined in this manual is drawn from information supplied by factory authorized installation technicians. Although this network can be installed on any vehicle, all manuals demonstrate the installation procedure using a 1995 Ford Crown Victoria as example. The basic procedures, however, do apply to most other vehicles. This manual is written with the assumption that the MPC01 Multi-Purpose Controller and BLDIST1 Power Distribution Center have already been installed and wired in your vehicle.

Mounting the BL627

1. Remove both sections of the rear seat from the vehicle.
2. Remove both the front and rear, driver side sill plate.
3. Remove the front, driver side kick panel.
4. Remove the driver side B-pillar molding from the vehicle.
5. From inside the trunk, position the BL627 against the vertical trunk wall behind the rear seat. Be sure that the BL627 fits properly and does not interfere with any parts of the trunk or seat back (Fig. 1).
6. Now position the BL627 Drilling Template (included) on the proposed mounting location.
7. Carefully drill the indicated holes using a #30 drill bit.
8. Using the supplied #8 x 5/8" sheet metal screws, secure the BL627 to the vertical trunk wall.

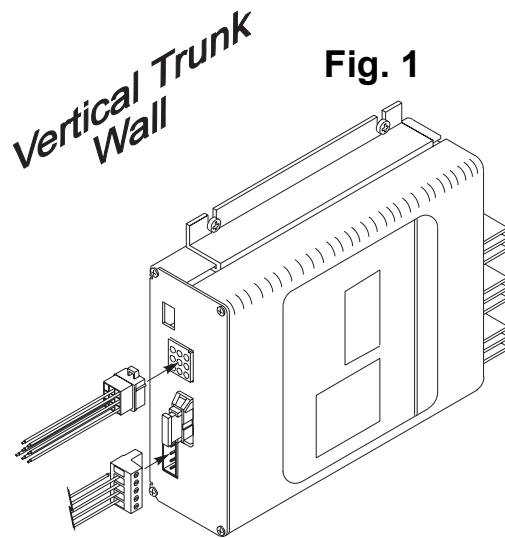

Wiring the BL627

Communication Cable

1. Locate the Communication Cable from the MPC01. This cable should have been routed from the MPC01 to the trunk when the MPC01 was installed. If this cable has not been routed yet, refer to the MPC01 installation manual for this procedure.
2. Cut the communication cable to length.
3. Strip approximately 2" of the cable jacket off the communication cable. Be careful not to cut the non-insulated, drain wire.
4. Strip 1/4" of insulation off each of the four (4) insulated wires.
5. Insert these wires, along with the non insulated drain wire, into the BL627 Phoenix™ connector as shown in Fig. 1.
6. Secure these wires with a small, flat blade screwdriver.
7. Insert the communication connector into the BL627 communications port.

Input/Output Connector

Note: A power distribution block is referenced in the following steps. This device is not necessary for a successful installation. It provides a fused and grounded power source and can be mounted in the trunk of your vehicle. Contact your Whelen representative for ordering details.

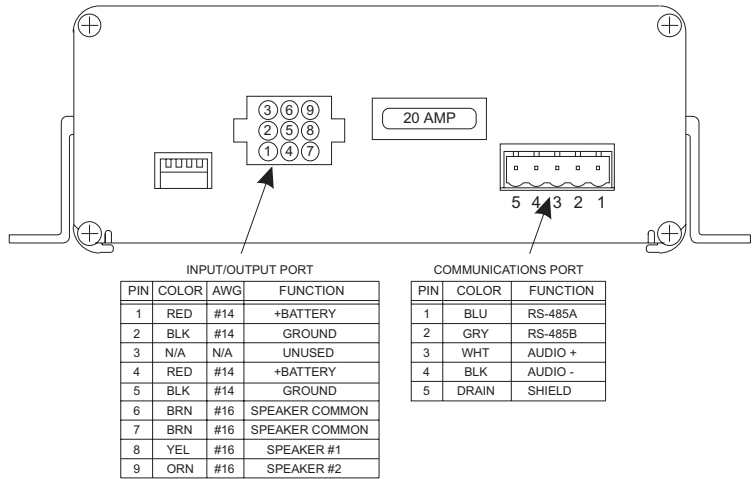

Route and connect the Input/Output connector harness wires as follows:

- 2 RED Wires - To the power distribution block; Connect both to a 25 Amp fused position.
- 2 BLACK Wires- To the power distribution block; Connect both to a grounded spade terminal.
- Yellow & Brown Wires- Route both of these wires through the vertical trunk wall into the vehicle. Route the wires along the driver side rocker sill and through the firewall. Select a factory wire harness that runs toward your number 1 siren speaker (the term "number 1" is user defined and is only referenced as a way to distinguish one speaker from another). Route the YELLOW and BROWN wires along this harness and connect to speaker 1 as follows:
 - YELLOW - Connect to the Positive (+) terminal on Speaker 1
 - BROWN - Connect to the Negative (-) terminal on Speaker 1
- Orange & Brown Wires- Route these wires as shown in the previous step *EXCEPT* route these wires towards Speaker 2 and connect as follows:
 - ORANGE - Connect to the Positive (+) terminal on Speaker 2
 - BROWN - Connect to the Negative (-) terminal on Speaker 2

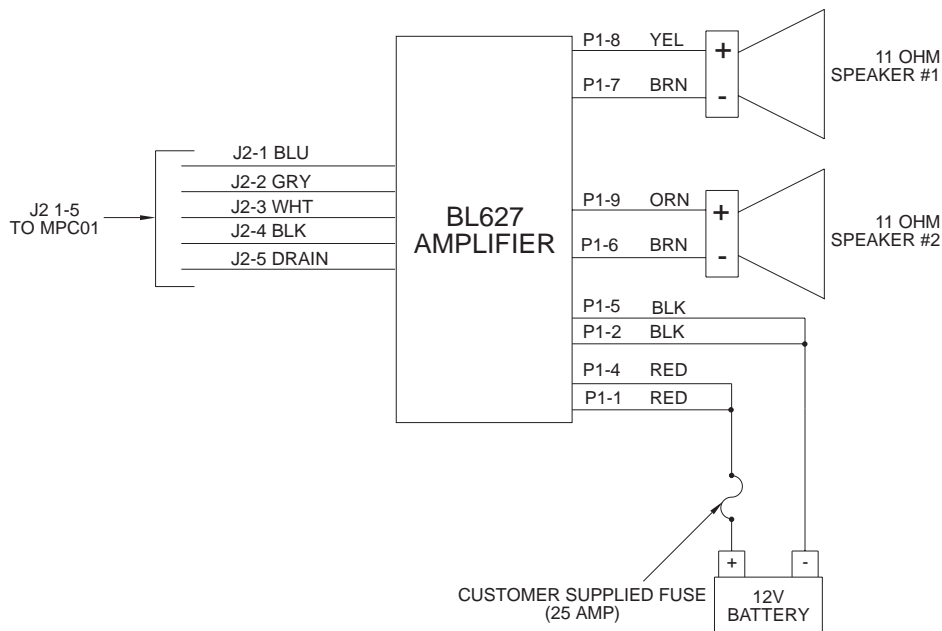

BL627 Mounting Template

