

WHELEN[®]

ENGINEERING COMPANY INC.

51 Winthrop Road
Chester, Connecticut 06412-0684
Phone: (860) 526-9504
Fax: (860) 526-4078
Internet: www.whelen.com
Sales e-mail: autosale@whelen.com
Canadian Sales e-mail: autocan@whelen.com
Customer Service e-mail: custserv@whelen.com

Replacement Guide: Edge[®] Series Power Supply

Safety First

This document provides all the necessary information to allow your Whelen product to be properly and safely installed. Before beginning the installation and/or operation of your new product, the installation technician and operator must read this manual completely. Important information is contained herein that could prevent serious injury or damage.

- Proper installation of this product requires the installer to have a good understanding of automotive electronics, systems and procedures.
- If mounting this product requires drilling holes, the installer **MUST** be sure that no vehicle components or other vital parts could be damaged by the drilling process. Check both sides of the mounting surface before drilling begins. Also de-burr any holes and remove any metal shards or remnants. Install grommets into all wire passage holes.
- If this manual states that this product may be mounted with suction cups, magnets, tape or Velcro[®], clean the mounting surface with a 50/50 mix of isopropyl alcohol and water and dry thoroughly.
- Do not install this product or route any wires in the deployment area of your air bag. Equipment mounted or located in the air bag deployment area will damage or reduce the effectiveness of the air bag, or become a projectile that could cause serious personal injury or death. Refer to your vehicle owner's manual for the air bag deployment area. The User/Installer assumes full responsibility to determine proper mounting location, based on providing ultimate safety to all passengers inside the vehicle.
- For this product to operate at optimum efficiency, a good electrical connection to chassis ground must be made. The recommended procedure requires the product ground wire to be connected directly to the **NEGATIVE (-)** battery post.
- If this product uses a remote device to activate or control this product, make sure that this control is located in an area that allows both the vehicle and the control to be operated safely in any driving condition.
- Do not attempt to activate or control this device in a hazardous driving situation.
- This product contains either strobe light(s), halogen light(s), high-intensity LEDs or a combination of these lights. Do not stare directly into these lights. Momentary blindness and/or eye damage could result.
- Use only soap and water to clean the outer lens. Use of other chemicals could result in premature lens cracking (crazing) and discoloration. Lenses in this condition have significantly reduced effectiveness and should be replaced immediately. Inspect and operate this product regularly to confirm its proper operation and mounting condition. Do not use a pressure washer to clean this product.
- It is recommended that these instructions be stored in a safe place and referred to when performing maintenance and/or reinstallation of this product.
- **FAILURE TO FOLLOW THESE SAFETY PRECAUTIONS AND INSTRUCTIONS COULD RESULT IN DAMAGE TO THE PRODUCT OR VEHICLE AND/OR SERIOUS INJURY TO YOU AND YOUR PASSENGERS!**

For warranty information regarding this product, visit www.whelen.com/warranty

WARNING!!!

The strobe light power supply is a **HIGH VOLTAGE** device. You must wait at least 10 minutes after turning off the power to the system before starting any diagnostic or trouble shooting procedures that may bring you into contact with any internal components.

Removal of Existing Power Supply...

1. Remove endcap and lenses until you have access to your lightbar's power supply. Power supply is located in the center section of your lightbar.
2. Remove the two (2), 10 x 24 3/4" screws that hold the power supply in position (See Diagram 1.1).
3. Disconnect Power Harness and Internal Harness from power supply.
4. Remove power supply from lightbar.
5. If your lightbar has two (2) power supplies, repeat steps 1 through 4 for the second power supply.
6. If you are replacing the power supplies in an older lightbar (eight or more years old) you will have to remove any Guide Pins that are present. These pins prevent the newer style power supplies from being installed. These can be broken off of the lightbar's extrusion by hitting them with a hammer.

Installation of New Power Supply...

1. If your previous power supply was equipped with a drip cover attached, this must be removed and transferred onto the new power supply. The drip cover is held in place by one screw and is mounted onto the new power supply in the same fashion as it was on the previous power supply.
2. Position your new power supply in it's general mounting location.
3. Connect the Power Harness and Internal Harness to the power supply. Refer to Table 1 for Correct Adaptor Cable(s).
4. With harness plugs connected, the power supply is ready to be mounted onto your lightbar.

TABLE 1

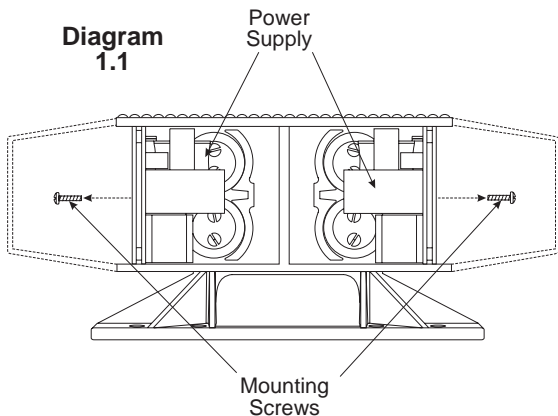

IF YOU HAVE LIGHTBAR MODEL #...	WITH POWER SUPPLY #...	YOU NEED POWER SUPPLY #...	WITH ADAPTOR CABLE(S) #...
9004SL, 9004WB, 9801, 9802, 9806 MINI EDGE@...	ZF, 1ZF	2ZFO	46-0741909-00 46-0741908-00
9004SL, 9004WB, 9801, 9802, 9804, 9806, 9004AK MINI EDGE...	ZS, 1ZS, 5ZS, ZSM	2ZSO	46-0745715-00 *LOW POWER SWITCHING MODIFICATION
9104, 9206, 9206WB, 9308, 9308WB, 9000FM....	ZF, 1ZF	2ZFO	46-0745715-00 46-0745815-00
9104, 9206, 9206WB, 9308, 9308WB, 9000FM....	5ZF, ZFM	2ZFO	46-0745715-00 46-0745815-00
9004SL/AK, 9004WB, 9801, 9802, 9804, 9806, MINI EDGE...	ZSO	2ZSO	NONE *LOW POWER SWITCHING MODIFICATION
9104, 9206, 9308, 9000FM, 9206WB...	ZFO	2ZFO	NONE

* **LOW POWER MODIFICATION** - OLD POWER SUPPLY WAS GROUND ACTIVATION TO VIOLET FOR HI-POWER. NEW SUPPLY IS +12 VOLT MOMENTARY ACTIVATION TO VIOLET FOR LOW POWER

Model 2ZSO

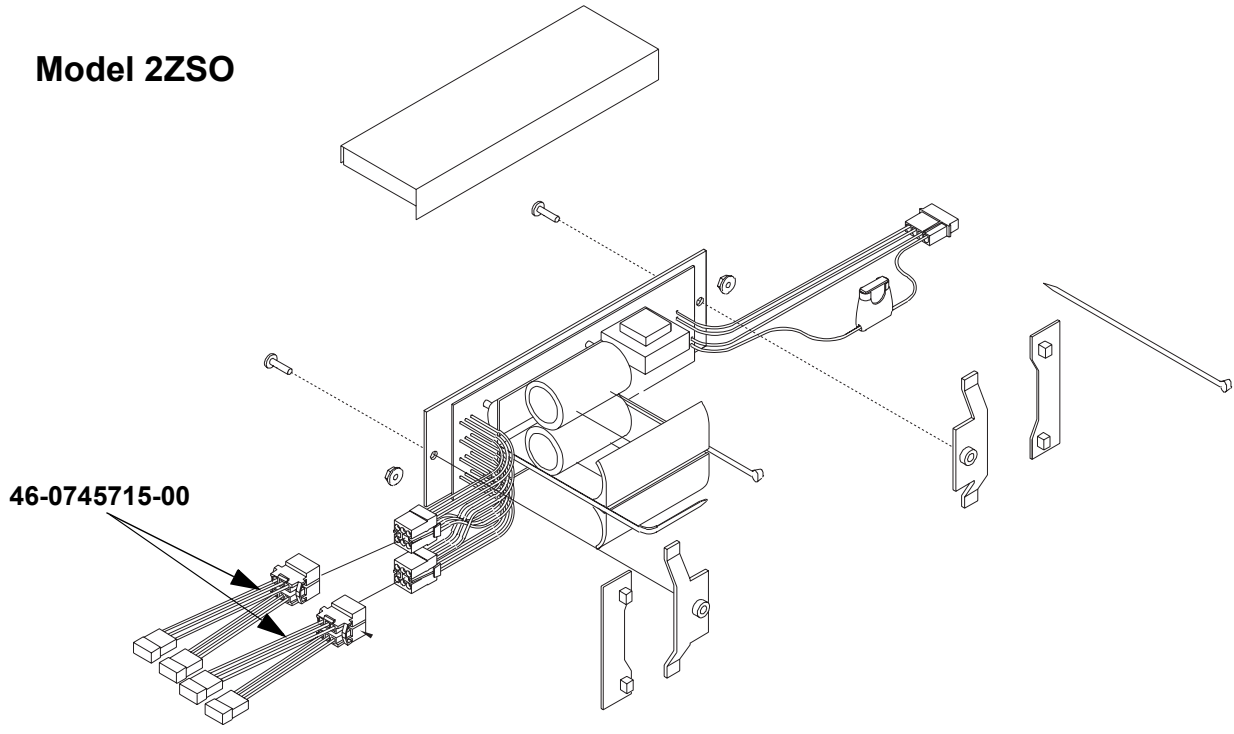

Model 2ZFO

