

# WHELEN<sup>®</sup>

ENGINEERING COMPANY INC.

Route 145, Winthrop Road,  
Chester, Connecticut 06412

Phone: (860) 526-9504

Fax: (860) 525-4078

Internet: [www.whelen.com](http://www.whelen.com)

Sales e-mail: [autosale@whelen.com](mailto:autosale@whelen.com)

Canadian Sales e-mail: [autocan@whelen.com](mailto:autocan@whelen.com)

Customer Service e-mail: [custserv@whelen.com](mailto:custserv@whelen.com)

## Installation Guide: BLDISTI Power Distribution Module

### Automotive: Serial Communication

### Safety First

This document provides all the necessary information to allow your Whelen product to be properly and safely installed. Before beginning the installation and/or operation of your new product, the installation technician and operator must read this manual completely. Important information is contained herein that could prevent serious injury or damage.

- **Proper installation of this product requires the installer to have a good understanding of automotive electronics, systems and procedures.**
- **If mounting this product requires drilling holes, the installer MUST be sure that no vehicle components or other vital parts could be damaged by the drilling process. Check both sides of the mounting surface before drilling begins. Also de-burr any holes and remove any metal shards or remnants. Install grommets into all wire passage holes.**
- **If this manual states that this product may be mounted with suction cups, magnets, tape or Velcro™, clean the mounting surface with a 50/50 mix of isopropyl alcohol and water and dry thoroughly.**
- **Do not install this product or route any wires in the deployment area of your air bag. Equipment mounted or located in the air bag deployment area will damage or reduce the effectiveness of the air bag, or become a projectile that could cause serious personal injury or death. Refer to your vehicle owners manual for the air bag deployment area. The User/Installer assumes full responsibility to determine proper mounting location, based on providing ultimate safety to all passengers inside the vehicle.**
- **For this product to operate at optimum efficiency, a good electrical connection to chassis ground must be made. The recommended procedure requires the product ground wire to be connected directly to the NEGATIVE (-) battery post.**
- **If this product uses a remote device to activate or control this product, make sure that this device is located in an area that allows both the vehicle and the device to be operated safely in any driving condition.**
- **Do not attempt to activate or control this device in a hazardous driving situation.**
- **If this product contains strobe light(s), halogen light(s) or high-intensity LEDs, do not stare directly into these lights. Momentary blindness and/or eye damage could result.**
- **Use only soap and water to clean the outer lens. Use of other chemicals could result in premature lens cracking (crazing) and discoloration. Lenses in this condition have significantly reduced effectiveness and should be replaced immediately. Inspect and operate this product regularly to confirm its proper operation and mounting condition. Do not use a pressure washer to clean this product.**
- **It is recommended that these instructions be stored in a safe place and referred to when performing maintenance and/or reinstallation of this product.**
- **FAILURE TO FOLLOW THESE SAFETY PRECAUTIONS AND INSTRUCTIONS COULD RESULT IN DAMAGE TO THE PRODUCT OR VEHICLE AND/OR SERIOUS INJURY TO YOU AND YOUR PASSENGERS!**

**For warranty information regarding this product, visit [www.whelen.com/warranty](http://www.whelen.com/warranty)**

## Notice!

This BLDISTI power distribution module, can be installed in many different types of vehicles. The guidelines for the installation of this product are written so that no matter what vehicle is being used, the installation and operation of the BLDISTI will be simple and straight forward.

## What is the BLDISTI?...

The BLDISTI Power Distribution Module provides a localized source where other Serial Communication components can access power and ground without having to route wires to the vehicle battery. In addition, the BLDISTI is equipped with special communication ports where the communication wires for each Serial Communication component can be connected.

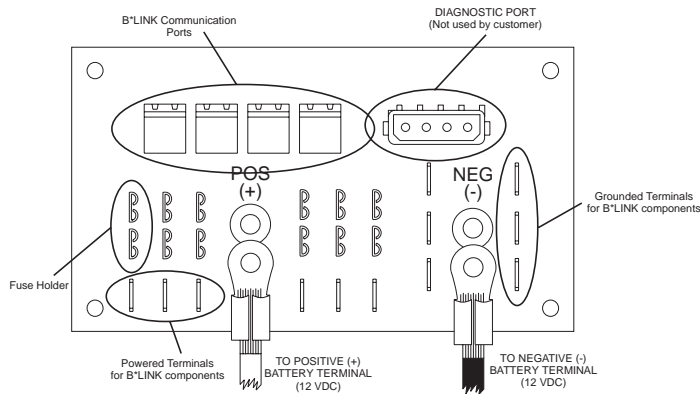

**IMPORTANT!** Do not connect the BL420 Halogen Power Supply (if it is switching more than 20 total amps) or the Edge 10000 Lightbar (in any configuration) to the BLDISTI! The current draw for either of these particular components exceeds the capacity of the BLDISTI.

The nature of the BLDISTI makes it imperative that all wire connection guidelines are strictly followed. The tables included in this manual contain important information that must be followed in order to ensure proper installation.

## Selecting a mounting location...

The BLDISTI should be mounted in the same location as the majority of the other installed serial communication components. For example, if the other components are mounted (or to be mounted) in the trunk or similar compartment, the BLDISTI should also be mounted in the same location. Regardless of the area chosen, keep the following advisories in mind:

- **The BLDISTI should be mounted on a metal surface to aid heat dissipation. Be sure that this surface is not one that either generates or is exposed to excessive heat during normal operation of the vehicle.**
- **Do not select a location where the BLDISTI will be exposed to potential damage from any unsecured or loose equipment in the vehicle.**
- **Be sure the area selected will not allow the BLDISTI to be exposed to water!**

- **When routing the BLDISTI's wires, it is important to choose a path that will keep these wires away from excessive heat and from any vehicle equipment that could compromise the integrity of the wires (ex. trunk lids, door jams, etc.).**

When the best mounting location has been determined, securely fasten the BLDISTI to its mounting surface using the supplied hardware.

**Caution: As it will be necessary to drill holes into the mounting surface, the installer MUST be sure that no vehicle components or other vital parts could be damaged by the drilling process. Check both sides of the mounting surface before drilling begins!**

## Connecting the BLDISTI to the vehicle battery...

Because of the large number of possible system configurations, the current load through the BLDISTI will vary from vehicle to vehicle. To ensure that the proper wire size is used to connect the BLDISTI to the vehicle battery, use the "BLDISTI Current Draw" table to calculate how much current the BLDISTI draws, based on the installed components. Now measure the length of the wire connecting the BLDISTI to the battery will have to travel. With these two values determine the proper wire gage by using the "Wire Gage Calculation Chart". The gage that has been determined will be used for both of the wires (POS and NEG) that are to be connected to the battery.

Route the properly sized wire from the factory chassis ground (adjacent to the NEGATIVE (-) terminal of the vehicle battery) to the NEGATIVE (-) post on the BLDISTI. Install a ring terminal in the end of this wire. Place the ring terminal on the NEGATIVE post and secure firmly with the provided stud nut.

**Caution: Before connecting the POSITIVE (+) battery terminal wire to the BLDISTI, make sure that there are no components connected to the BLDISTI and that there are no fuses installed in the fuse locations on the BLDISTI!**

Route the properly sized wire from the factory auxiliary power terminal (if vehicle is so equipped) to a customer supplied fuse block. There should be no more than 2 (two) feet of wire between the fuse block and the power source. The correct amperage rating for the fuse used in this block can be determined using the "BLDISTI Current Draw" table. Now extend the properly sized wire from the fuse block to the POSITIVE (+) post on the BLDISTI. Install a ring terminal in the end of this wire. Place the ring terminal on the POSITIVE post and secure firmly with the provided stud nut.

**WARNING! All customer supplied wires that connect to the positive terminal of the battery must be sized to supply at least 125% of the maximum operating current and FUSED at the battery to carry that load. DO NOT USE CIRCUIT BREAKERS WITH THIS PRODUCT!**

### Connecting Communication wires to the BLDISTI...

The B\*LINK communication wires (BLUE & GREY) begin at the MPC01. From there, these are routed (in twisted-pair configuration) to the BL627 siren amplifier.

**Caution:** Confirm that the BLUE wire is connected to the COM port marked "A" and that the GREY wire is connected to the COM port marked "B".

From the BL627's COM port, extend the BLUE & GREY twisted-pair wires to the BLDISTI's COM port. As you will see, there are 4 (four) sets of COM ports that may be used. Select a COM port and insert the BLUE wire into port "A" and insert the GREY wire into port "B". Secure these wires to the COM port with a small flat blade screwdriver.

The BLDISTI is now ready to supply power, ground and communication with other B\*LINK components.

### Connecting Components to the BLDISTI...

Refer to the wiring diagram located in the installation manual for the component being connected to the BLDISTI. Extend the wires as illustrated except route the units power and ground wires to the BLDISTI and not to the vehicle battery. Install an appropriately sized spade connector on the ends of both the POWER and GROUND wires. Connect the POWER wire to one of the spade terminals designated for access to power. Install the proper fuse for the component in the fuse holder directly above the spade terminal (refer to "BLDISTI Current Draw" for proper fuse size). Connect the GROUND wire to any of the spade terminals designated for access to ground. These terminals are adjacent to the NEGATIVE battery wire post.

Now extend the communication wires (in twisted-pair configuration) to the BLDISTI. Select a COM port and insert the BLUE wire into the port marked "A" and the GREY wire into the PORT marked "B".

**Note:** The communication wires can be inserted into a COM port already in use. Remember that BLUE goes into port "A" and GREY goes into "B".

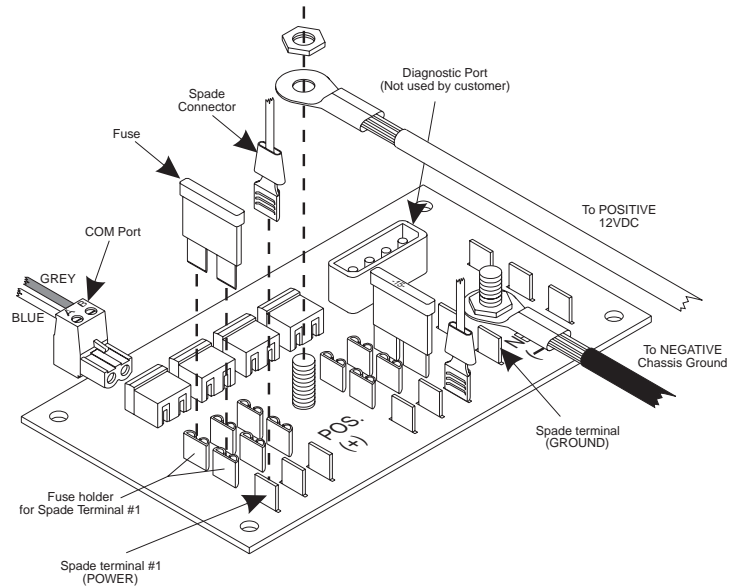

## BLDISTI Current Draw

		Quantity	Maximum Current Draw	Fuse B*LINK Component @
MPC01 Multi-Purpose Controller	<input checked="" type="checkbox"/>	1	x 1 Amp = 1	5 Amps
BL627 Siren Amplifier (Single Speaker)	<input type="checkbox"/>		x 8 Amps = +	20 Amps*
BL627 Siren Amplifier (Dual Speaker)	<input type="checkbox"/>		x 16 Amps = +	20 Amps
BL94C 4 Outlet Strobe Power Supply	<input type="checkbox"/>		x 9 Amps = +	15 Amps
BL188C 8 Outlet Strobe Power Supply	<input type="checkbox"/>		x 18 Amps = +	25 Amps
BL420 4 Outlet Halogen Power Supply	<input type="checkbox"/>		x 80 Amps** = +	100 Amps
BL405 4 Outlet Power Switch	<input type="checkbox"/>		x 20 Amps*** = +	25 Amps
BL2150 Headlight Flasher	<input type="checkbox"/>		x 12 Amps = +	15 Amps
BL5150 Taillight Flasher	<input type="checkbox"/>		x 12 Amps = +	15 Amps
BL10000 Lightbar	<input type="checkbox"/>		x ? Amps = +	? Amps
BLTAREM Traffic Advisor	<input type="checkbox"/>		x 12 Amps = +	15 Amps

\* = Fused for 2 speakers (std).

\*\* = MAX current shown (4 outlets X 20 amps per outlet)  
If module switches more than 20 total amps DO NOT connect to BLDISTI.  
Must be connected and fused at the battery!

\*\*\* = MAX allowable current switched by module.  
Actual current may be lower (to be fused appropriately).

\_\_\_\_\_ = Total BLDISTI Current Draw

### To determine main fuse size...

Total BLDISTI Current Draw x 1.25 = main fuse (amps)

# Wire Gauge Calculation Chart

## Maximum Current Draw Through The BLDISTI

Wire Gauge	5 Amps	10 Amps	15 Amps	20 Amps	25 Amps	30 Amps	35 Amps	40 Amps	45 Amps	50 Amps
22 AWG	6 Feet	3 Feet	Insufficient	Insufficient	Insufficient	Insufficient	Insufficient	Insufficient	Insufficient	Insufficient
20 AWG	9.5 Feet	5 Feet	3 Feet	Insufficient	Insufficient	Insufficient	Insufficient	Insufficient	Insufficient	Insufficient
18 AWG	15 Feet	7.5 Feet	5 Feet	4 Feet	3 Feet	Insufficient	Insufficient	Insufficient	Insufficient	Insufficient
16 AWG	24.5 Feet	12 Feet	8 Feet	6 Feet	5 Feet	4 Feet	3.5 Feet	3 Feet	Insufficient	Insufficient
14 AWG	39 Feet	19.5 Feet	13 Feet	9.5 Feet	8 Feet	6.5 Feet	5.5 Feet	5 Feet	4.5 Feet	4 Feet
12 AWG	62 Feet	31 Feet	20.5 Feet	15.5 Feet	12.5 Feet	10.5 Feet	9 Feet	7.5 Feet	7 Feet	6 Feet
10 AWG	98 Feet	49 Feet	32.5 Feet	24.5 Feet	19.5 Feet	16.5 Feet	14 Feet	12.5 Feet	11 Feet	10 Feet
8 AWG	156 Feet	78 Feet	52 Feet	39 Feet	31 Feet	26 Feet	22.5 Feet	19.5 Feet	17.5 Feet	15.5 Feet
6 AWG	248.5 Feet	124 Feet	82.5 Feet	62 Feet	49.5 Feet	41.5 Feet	35.5 Feet	31 Feet	27.5 Feet	25 Feet
4 AWG	395 Feet	197.5 Feet	131 Feet	98.5 Feet	79 Feet	66 Feet	56.5 Feet	49.5 Feet	44 Feet	39.5 Feet
2 AWG	629 Feet	314 Feet	209 Feet	157 Feet	125.5 Feet	104.5 Feet	89.5 Feet	78.5 Feet	69.5 Feet	63 Feet

## Maximum Current Draw Through The BLDISTI

Wire Gauge	55 Amps	60 Amps	65 Amps	70 Amps	75 Amps	80 Amps	85 Amps	90 Amps	95 Amps	100 Amps
22 AWG	Insufficient	Insufficient	Insufficient	Insufficient	Insufficient	Insufficient	Insufficient	Insufficient	Insufficient	Insufficient
20 AWG	Insufficient	Insufficient	Insufficient	Insufficient	Insufficient	Insufficient	Insufficient	Insufficient	Insufficient	Insufficient
18 AWG	Insufficient	Insufficient	Insufficient	Insufficient	Insufficient	Insufficient	Insufficient	Insufficient	Insufficient	Insufficient
16 AWG	Insufficient	Insufficient	Insufficient	Insufficient	Insufficient	Insufficient	Insufficient	Insufficient	Insufficient	Insufficient
14 AWG	3.5 Feet	3 Feet	3 Feet	3 Feet	Insufficient	Insufficient	Insufficient	Insufficient	Insufficient	Insufficient
12 AWG	5.5 Feet	5 Feet	5 Feet	4.5 Feet	4 Feet	4 Feet	3.5 Feet	3.5 Feet	3.5 Feet	3 Feet
10 AWG	9 Feet	8 Feet	7.5 Feet	7 Feet	6.5 Feet	6 Feet	6 Feet	5.5 Feet	5 Feet	5 Feet
8 AWG	14 Feet	13 Feet	12 Feet	11 Feet	10.5 Feet	10 Feet	9 Feet	8.5 Feet	8 Feet	8 Feet
6 AWG	22.5 Feet	20.5 Feet	19 Feet	17.5 Feet	16.5 Feet	15.5 Feet	14.5 Feet	14 Feet	13 Feet	12.5 Feet
4 AWG	36 Feet	33 Feet	30.5 Feet	28 Feet	26.5 Feet	24.5 Feet	23 Feet	22 Feet	21 Feet	19.5 Feet
2 AWG	57 Feet	52.5 Feet	48.5 Feet	45 Feet	42 Feet	39 Feet	37 Feet	35 Feet	33 Feet	31.5 Feet

Using this chart as described below, determine the proper AWG (gauge) rating for the BLDISTI's main power and ground wires. Be sure to size **both** wires to this gage.

- 1) Determine your BLDISTI's maximum current draw
- 2) Find the column that matches your BLDISTI's current draw
- 3) Within that column, find the row that best represents the distance a length of wire will travel to connect the BLDISTI to the vehicle battery.
- 4) The heading for this row indicates the minimum size AWG (gauge) your power and ground wires will be in order to safely carry your BLDISTI's current draw.

# Typical connections to BLDISTI

