

WHELEN[®]

ENGINEERING COMPANY INC.

Route 145, Winthrop Road,

Chester, Connecticut 06412

Phone: (860) 526-9504

Fax: (860) 526-4078

Internet: www.whelen.com

Sales e-mail: autosale@whelen.com

Canadian Sales e-mail: autocan@whelen.com

Customer Service e-mail: custserv@whelen.com

Installation/Operating Manual: WS295HFS1-series Siren

Automotive: Sirens/Switches

Safety First

This document provides all the necessary information to allow your Whelen product to be properly and safely installed. Before beginning the installation and/or operation of your new product, the installation technician and operator must read this manual completely. Important information is contained herein that could prevent serious injury or damage.

- **Proper installation of this product requires the installer to have a good understanding of automotive electronics, systems and procedures.**
- **If mounting this product requires drilling holes, the installer MUST be sure that no vehicle components or other vital parts could be damaged by the drilling process. Check both sides of the mounting surface before drilling begins. Also de-burr any holes and remove any metal shards or remnants. Install grommets into all wire passage holes.**
- **If this product is mounted with tape or Velcro™, clean the mounting surface with a 50/50 mix of isopropyl alcohol and water and dry thoroughly.**
- **Do not install this product or route any wires in the deployment area of your air bag. Equipment mounted or located in the air bag deployment area will damage or reduce the effectiveness of the air bag, or become a projectile that could cause serious personal injury or death. Refer to your vehicle owners manual for the air bag deployment area. The User/Installer assumes full responsibility to determine proper mounting location, based on providing ultimate safety to all passengers inside the vehicle.**
- **For this product to operate at optimum efficiency, a good electrical connection to chassis ground must be made. The recommended procedure requires the product ground wire to be connected directly to the NEGATIVE (-) battery post.**
- **If this product uses a remote device to activate or control this product, make sure that this control is located in an area that allows both the vehicle and the control to be operated safely in any driving condition.**
- **Do not attempt to activate or control this device in a hazardous driving situation.**
- **It is recommended that these instructions be stored in a safe place and referred to when performing maintenance and/or reinstallation of this product.**
- **FAILURE TO FOLLOW THESE SAFETY PRECAUTIONS AND INSTRUCTIONS COULD RESULT IN DAMAGE TO THE PRODUCT OR VEHICLE AND/OR SERIOUS INJURY TO YOU AND YOUR PASSENGERS!**

WARNING!

DISCONNECTING THE VEHICLE BRAKE LAMP CIRCUIT USING ANY SIRENS WITH RELAY OUTPUTS OR SWITCH CONTROLLERS COULD CAUSE VEHICLE OR PROPERTY DAMAGE, SERIOUS INJURY OR EVEN DEATH.

DISABLING THIS CIRCUIT IS A VIOLATION OF THE FEDERAL MOTOR VEHICLE SAFETY STANDARD FOR THE THIRD BRAKE LIGHT, AS WELL AS REAR BRAKE LIGHTS.

FUNCTIONS THAT BLACK OUT THE REAR BRAKE LIGHTS (SOMETIMES CALLED “BRAKE LIGHT CUT OUT”) MAY INTERFERE WITH THE BRAKE SHIFT LOCK MECHANISM, AND CAUSE THE VEHICLE TO MOVE UNEXPECTEDLY AND DANGEROUSLY.

DISCONNECTING THE BRAKE LIGHTS IN ANY WAY IS AT YOUR OWN RISK AND IS NOT RECOMMENDED BY WHELEN.

Installation...

The WS295HFS1, although technologically advanced, is simple to install. An aftermarket center console is the recommended for the mounting location of the WS295HFS1. This not only allows the driver to reach the controls easily, but also keeps the unit safely out of the path of the vehicle's SRS air-bag. Follow the console manufacturer's instructions for mounting information. If a console-type mount is not possible, the WS295HFS1 includes a bail strap mounting kit for over- or under-dash mounting.

READ BEFORE INSTALLING!!!

Do not install this product or route any wires in the deployment area of your airbag. Equipment mounted or located in the airbag deployment area will damage or reduce the effectiveness of the airbag, or become a projectile that could cause serious personal injury or death. Refer to your vehicle owners manual for the air bag deployment area.

The User/Installer assumes full responsibility to determine proper mounting location, based on providing ultimate safety to all passengers inside the vehicle. Whelen Engineering Company assumes no liability or responsibility for determining individual applications or exact installation location criteria.

The following steps will guide you through the installation process:

Connecting The WS295HFS1 Power & Ground Wires (Red and Black):

RED (Power) and BLACK (Ground)

1. Remove the driver's side front seat.
2. Remove the front, driver's side rocker sill plate and kick panel.
3. Fold back the floor covering so that access is gained to the factory wire harness routed under the driver's seat area.
4. Insert the wiring harness into it's port as shown in Fig. 1.
5. Extend the two RED and two BLACK wires toward the sill plate location. Follow the same path as the factory wire harness.

WARNING: All customer supplied wires that connect to the POSITIVE (+) terminal of the battery must be sized to supply at least 125% of the maximum operating current and be fused "at the battery" to carry that load!

6. Continue to follow the factory harness through the firewall. To pass the RED and BLACK wires through, it may be necessary to drill a hole in the firewall. If so, be absolutely sure that there are no components that could be damaged by drilling. After the hole is drilled, insert a grommet to protect the wires.
7. Route the RED and BLACK wires along the factory harness towards the battery.
8. Install a 20 amp fuse block (user supplied) on the end of the RED wire.

Note: Remove the fuse from the fuse block before connecting any wires to the battery!

9. Connect the fuse block wire to the POSITIVE (+) terminal on the battery. There must not be more than 2 ft. of wire between the fuse block and the battery. As the wire between the fuse and the battery is "unprotected", do not allow this wire to come in contact with any other wires!

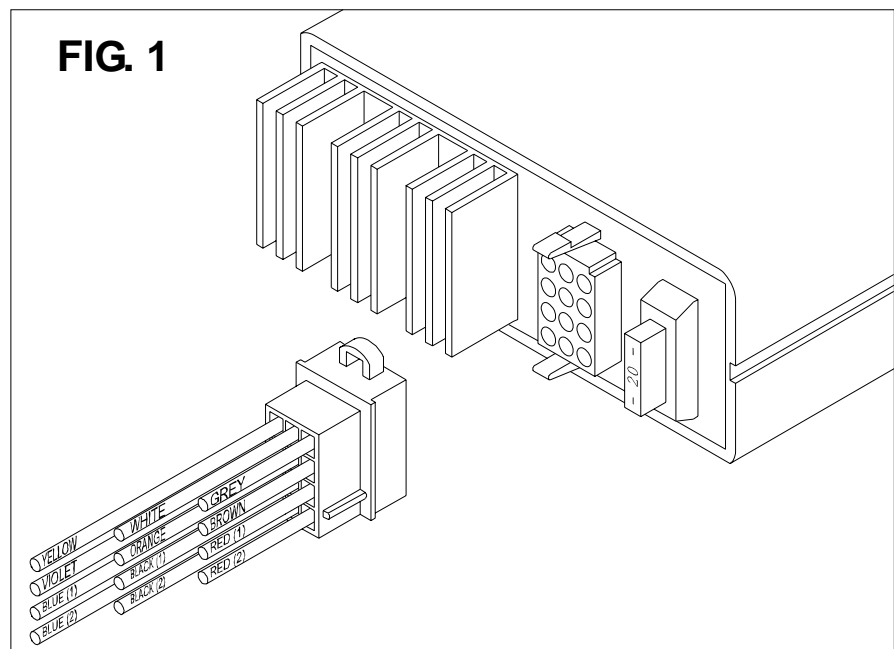

10. Connect the BLACK wire to the factory chassis ground, adjacent to the battery.

Connecting The WS295HFS1 Speaker Wires (Yellow, Orange & Brown):

1. Route the YELLOW, ORANGE and BROWN wires along the factory wire harness and through the firewall at the same point as the RED and BLACK wires.
2. Route these wires toward the vehicle siren speakers.
3. Connect the YELLOW wire to the POSITIVE speaker connection on speaker #1.
4. Connect the ORANGE wire to the POSITIVE speaker connection on speaker #2.
5. Connect the BROWN wire to the NEGATIVE speaker connection on speaker #2.
6. Splice a wire from the NEGATIVE speaker connection on speaker #1 to the NEGATIVE speaker connection on speaker # 2.

Connecting The WS295HFS1 Horn Relay Wires (White & Grey):

1. Route the WHITE and GREY wires along the factory wire harness and through the firewall at the same point as the RED and BLACK wires.
2. Locate your vehicle's horn relay and route the WHITE and GREY wires to this. If possible, follow the factory wire harness to this relay.
3. Locate the wire that connects the vehicle horn to the horn relay.
4. Cut this wire.
5. Connect the WHITE wire to the wire coming from the horn relay.
6. Connect the GREY wire to the wire coming from the horn.

Note:The two (2) remaining BLUE wires are used to connect your two-way radio's external speaker to the WS295HFS1 for radio re-broadcast. This is an optional connection and does not effect the other operations of the WS295HFS1.

Note:Radio re-broadcast will NOT work with amplified remote speakers! If your remote speaker is amplified (I.E.: contains a power amp circuit in the speaker assembly), do not enable the radio re-broadcast feature.

1. Locate the two wires that connect the external speaker to the two-way radio.
2. Cut one of these wires and splice one of the BLUE wires into this circuit.
3. Cut the remaining speaker wire and splice the remaining BLUE wire into this circuit.

Connecting The WS295HFS1 To A Remote Control-head (optional)...

The WS295HFS1 may be connected to an existing control-head, such as the Whelen PCDS-9 or equivalent. This is an optional connection that enables the WAIL tone to be activated through the use of a PCDS-9 button or switch. If this connection is not chosen, cut the VIOLET wire and cap the remaining stub to prevent accidental grounding of the wire.

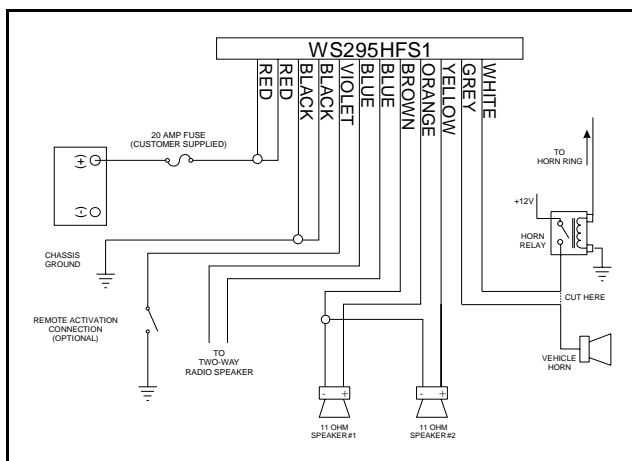

WS295HFS1 WIRING DIAGRAM

Operating the WS295HFS1 Controls:

Power Switch

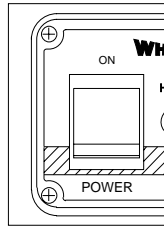

This switch has two positions: Down (WS295HFS1 - Off) and Up (WS295HFS1 - On). When this switch is in the Off position, the WS295HFS1 will not function. When the switch is in the On position the siren is functional and may be activated at the operator's discretion. *NOTE: If the WS295HFS1 is connected to the vehicle's horn ring circuit, the vehicle horn is disabled when the WS295HFS1 power switch is in the ON position.*

MAN Button

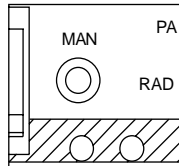

The Manual button generates a variety of tones, depending on what position the Rotary knob is in. For further explanation of this button's function, refer to the Rotary knob section of this manual.

Rotary Switch

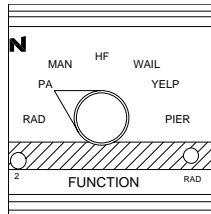

The Rotary Knob controls the siren and PA (Public Address) functions of the WS295HFS1. There are 7 positions that may be selected. Each position and its function is outlined below:

RAD (Radio Repeat) - When the rotary knob is in the RAD position, any signal that is received by the vehicle's two-way radio will be simultaneously broadcast over the vehicle's loudspeaker (the WS295HFS1 must be connected to the two-way radio as outlined in this manual). This function overrides any other siren function.

PA (Public Address) - When the rotary knob is in the PA position, public address functions are operational. Messages may be broadcast over the vehicle's loudspeaker when the WS295HFS1 microphone is in use. The volume level of PA transmissions is controlled by the volume knob. If the Manual button is pressed while the rotary knob is in this position, an "air horn" siren tone will be generated by your vehicle's loudspeaker. This tone is generated until the Manual button is released. The "air horn" may also be generated by pressing the vehicle's steering wheel horn button (if the vehicle's horn has been wired to the WS295HFS1).

MAN (Manual Siren) - When the rotary knob is in the MAN position, pressing the Manual button generates a tone that rises in pitch to a pre-set level. This tone is generated for as long as the Manual button is pressed. The same tone may be generated by pressing the vehicle's steering wheel horn button (if the vehicle's horn has been wired to the WS295HFS1). Please note that the WS295HFS1 microphone will override the siren function.

HF (Hands Free Operation) - When the rotary knob is in the HF position, the siren functions of the WS295HFS1 are placed in a stand-by mode. Siren tones are activated by a single "tap" on the MAN button or a single "tap" on the vehicle's steering wheel horn button (if the vehicle's horn has been wired to the WS295HFS1). The first "tap" produces a "Wail" tone (a steady, rise and fall tone). A second "tap" produces a "Yelp" tone (a fast, rise and fall tone). A third "tap" produces a "Piercer™" tone (an extremely fast, rise and fall tone). The next "tap" returns the siren to a "Wail" tone and the cycle repeats itself. Two quick, successive "taps" will stop the siren.

WAIL (Wail Tone) - When the rotary knob is in the WAIL position, a steady, rise and fall tone is produced. A single "tap" on the MAN button or a single "tap" on the vehicle's steering wheel horn button (if the vehicle's horn has been wired to the WS295HFS1), changes the siren tone to a "Yelp" pattern (a fast, rise and fall tone). A second "tap", and the siren returns to a "Wail" tone. Please note that the WS295HFS1 microphone will override the siren function.

YELP (Yelp Tone) - When the rotary knob is in the YELP position, a fast, rise and fall tone is produced. Pressing the MAN button or the vehicle's steering wheel horn button (if the vehicle's horn has been wired to the WS295HFS1), changes the siren tone to a simulated air horn tone for as long as the button is pressed. Releasing the button causes the siren to return to the Yelp tone. Please note that the WS295HFS1 microphone will override the siren function.

PIER (Piercer™ Tone) - When the rotary knob is in the PIER position, an extremely fast, rise and fall tone is produced. A pressing the MAN button or a single "tap" on the vehicle's steering wheel horn button (if the vehicle's horn has been wired to the WS295HFS1), changes the siren tone to a simulated air horn tone for as long as the button is pressed. Releasing the button causes the siren to return to the "Piercer™" tone. Please note that the WS295HFS1 microphone will override the siren function.

Volume Knob

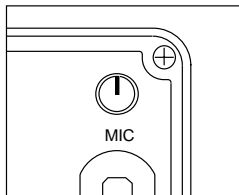

The Volume Knob controls the volume of Public Address function. Volume is increased by rotating the knob in a clockwise direction. Rotating the volume knob in a counter-clockwise direction decreases the volume produced by these features. The volume knob has no effect on any siren tones produced.

To Adjust the Radio Repeat Levels:

Before using the 295HFS1, the Radio Repeat output volume must be adjusted to satisfactory operating levels. To adjust this level, a small, flat blade screwdriver is needed.

Radio Repeat Volume

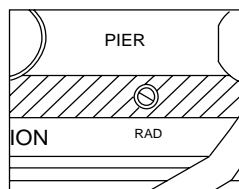

Locate the Radio Repeat adjustment port (potentiometer) to the right of the Rotary Knob on the face of the control head. Set the volume level of the vehicle's two-way radio to its normal operating volume. Turn the Rotary Knob on the control head to RAD to activate Radio Repeat. Insert the screwdriver in the Radio Repeat adjustment port and turn in clockwise direction to increase the sound level.

SI-TEST®

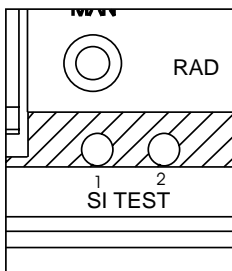

SI-TEST® is a diagnostic feature of the WS295HFS1 and allows the operator to confirm the proper operation of the siren speakers connected to the WS295HFS1 without activating an audible siren tone. To initiate SI-TEST® cycle, set the rotary knob to the RAD position. Now press and hold the MAN button for at least 5 seconds. As the siren is tested, its diagnostic indicator will turn on if no problems are detected. If the indicator flashes, a problem with either the siren or its connectors has been detected. Check the wire connections of the failed speaker and repeat the SI-TEST®. If the speaker fails the test again, have the siren itself inspected by a qualified technician. **NOTE:** *Installed speakers are tested by generating an ultra-high frequency tone through each speaker. Although these tones are inaudible to humans, be sure that there is nobody within 5 feet of the speakers when SI-TEST® is running.*

