

# WHELEN<sup>®</sup>

ENGINEERING COMPANY INC.

Route 145, Winthrop Road,

Chester, Connecticut 06412

Phone: (860) 526-9504

Fax: (860) 526-4078

Internet: [www.whelen.com](http://www.whelen.com)

Sales e-mail: [autosale@whelen.com](mailto:autosale@whelen.com)

Canadian Sales e-mail: [autocan@whelen.com](mailto:autocan@whelen.com)

Customer Service e-mail: [custserv@whelen.com](mailto:custserv@whelen.com)

## Installation Guide Model 810 Warning Light

### Safety First

This document provides all the necessary information to allow your Whelen product to be properly and safely installed. Before beginning the installation and/or operation of your new product, the installation technician and operator must read this manual completely. Important information is contained herein that could prevent serious injury or damage.

- **Proper installation of this product requires the installer to have a good understanding of automotive electronics, systems and procedures.**
- **If mounting this product requires drilling holes, the installer MUST be sure that no vehicle components or other vital parts could be damaged by the drilling process. Check both sides of the mounting surface before drilling begins. Also de-burr any holes and remove any metal shards or remnants. Install grommets into all wire passage holes.**
- **If this product is mounted with tape or Velcro™, clean the mounting surface with a 50/50 mix of isopropyl alcohol and water and dry thoroughly.**
- **Do not install this product or route any wires in the deployment area of your air bag. Equipment mounted or located in the air bag deployment area will damage or reduce the effectiveness of the air bag, or become a projectile that could cause serious personal injury or death. Refer to your vehicle owners manual for the air bag deployment area. The User/Installer assumes full responsibility to determine proper mounting location, based on providing ultimate safety to all passengers inside the vehicle.**
- **For this product to operate at optimum efficiency, a good electrical connection to chassis ground must be made. The recommended procedure requires the product ground wire to be connected directly to the NEGATIVE (-) battery post.**
- **If this product uses a remote device to activate or control this product, make sure that this control is located in an area that allows both the vehicle and the control to be operated safely in any driving condition.**
- **Do not attempt to activate or control this device in a hazardous driving situation.**
- **This product contains either strobe light(s), halogen light(s), high-intensity LED's or a combination of these lights. Do not stare directly into these lights. Momentary blindness and/or eye damage could result.**
- **Use only soap and water to clean the outer lens. Use of other chemicals could result in premature lens cracking (crazing) and discoloration. Lens' in this condition have significantly reduced effectiveness and should be replaced immediately. Inspect and operate this product regularly to confirm its proper operation and mounting condition. Do not use a pressure washer to clean this product.**
- **It is recommended that these instructions be stored in a safe place and referred to when performing maintenance and/or reinstallation of this product.**
- **FAILURE TO FOLLOW THESE SAFETY PRECAUTIONS AND INSTRUCTIONS COULD RESULT IN DAMAGE TO THE PRODUCT OR VEHICLE AND/OR SERIOUS INJURY TO YOU AND YOUR PASSENGERS!**

## Installation:

There are two ways to mount the 810 lighthead, each offering it's own benefits:

- **Secured to vehicle using supplied #10 x 1" sheet metal screws.**
- **Secured to vehicle using an industry-strength, double-sided adhesive tape, like Scotch™ brand VHB™ model 4956 foam tape.**

This manual will outline the first procedure.

1. Position the 810 lighthead in it's approximate mounting location. Make sure that the 810 will not interfere with any existing equipment. Also be aware of any and all items on the opposite side of the mounting surface to prevent any possible damage to existing components.
2. Position the supplied mounting template on the mounting location and temporarily secure it to the surface. Be sure the template is FLAT against the surface.

**Note: Before proceeding, place the reflector against the template and confirm that the mounting holes on the template line up with the actual mounting holes on the reflector.**

**Note: Be sure the gasket is mounted with the drain holes on the bottom. Each gasket is labeled.**

3. Using a #27 drill bit, drill the mounting holes as shown on the template.
4. The rectangle on the template represents the recommended location for the wiring hole. Drill a 5/8" wire access hole any where within this rectangle. DO NOT DRILL OUTSIDE OF THIS AREA.
5. Connect the RED wire to +12VDC and the WHITE wire to chassis ground. Fuse the RED wire at 7.5 amps.

**WARNING! All customer supplied wires that connect to the positive (+) terminal of the battery, must be sized to supply at least 125% of the maximum operating current, and fused "at the battery" to carry that load.**

6. After testing lamp operation, secure the reflector to the vehicle with the supplied mounting screws.
7. Mount the lens onto the reflector and secure with the supplied lens screw.

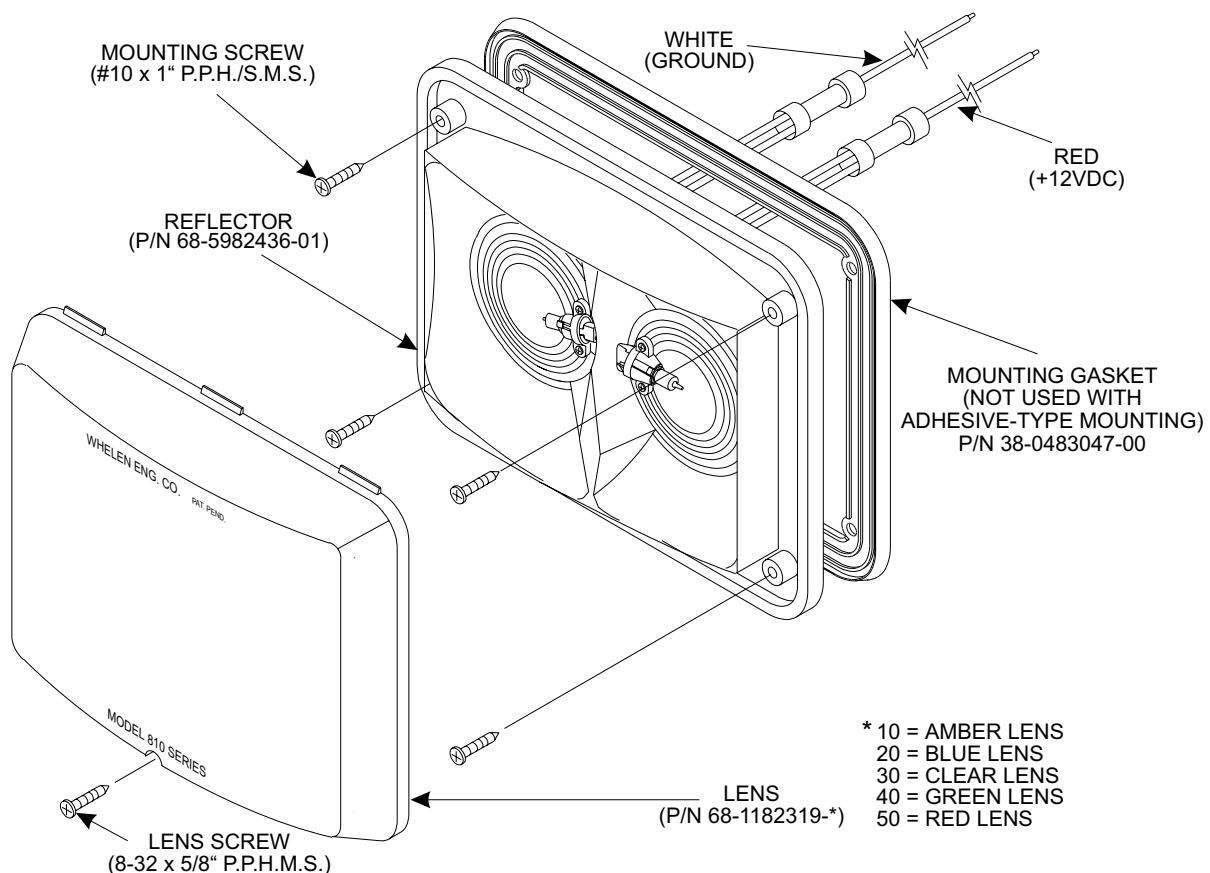

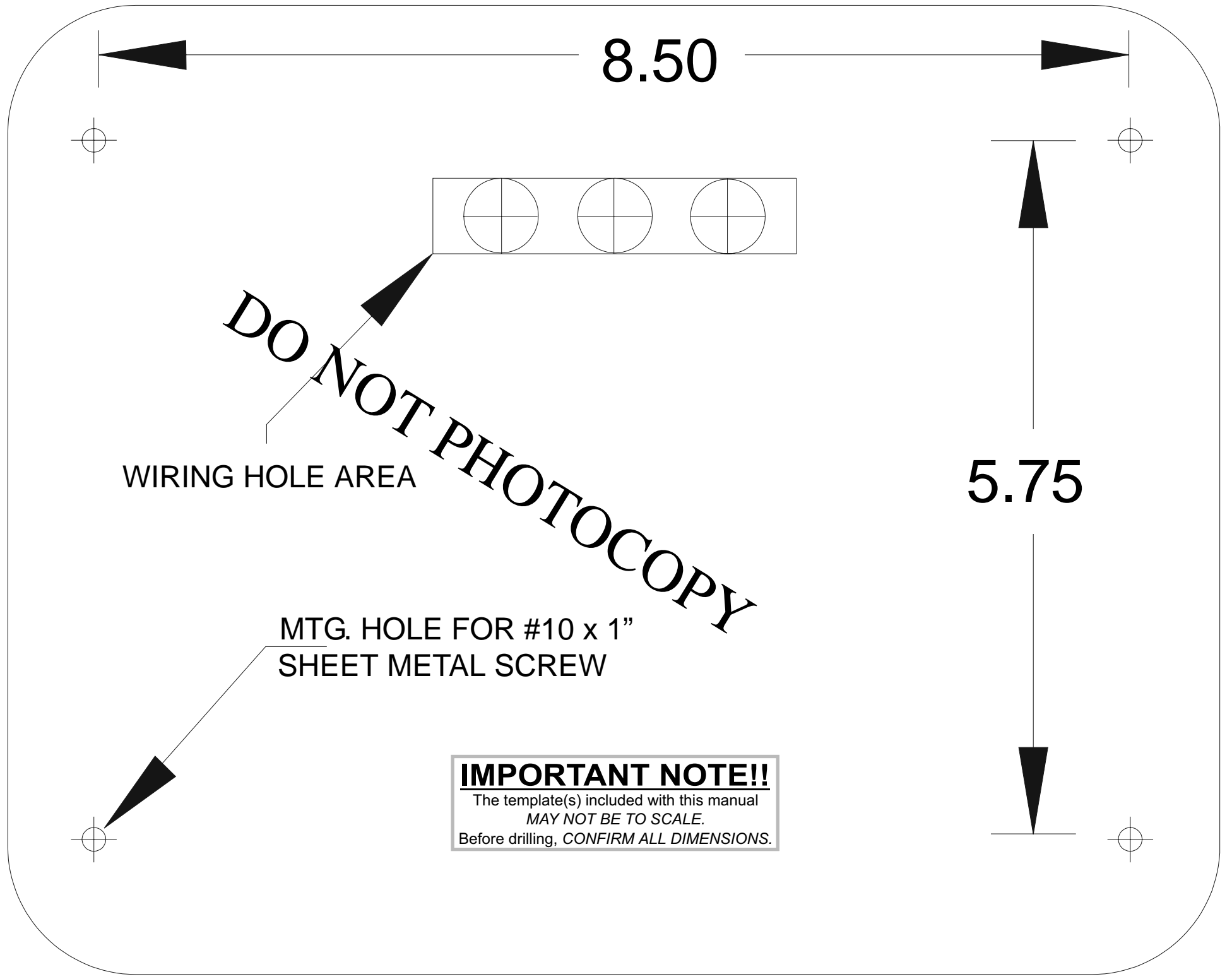

8.50

5.75

DO NOT PHOTOCOPY

WIRING HOLE AREA

MTG. HOLE FOR #10 x 1" SHEET METAL SCREW

**IMPORTANT NOTE!!**  
The template(s) included with this manual  
MAY NOT BE TO SCALE.  
Before drilling, CONFIRM ALL DIMENSIONS.