

WHELEN[®]

ENGINEERING COMPANY INC.

Route 145, Winthrop Road,
Chester, Connecticut 06412

Phone: (860) 526-9504

Fax: (860) 526-4078

Internet: www.whelen.com

Sales e-mail: autosale@whelen.com

Canadian Sales e-mail: autocan@whelen.com

Customer Service e-mail: custserv@whelen.com

Installation Guide Longhorn Siren 1997 E-350 Chassis (High & Low Trim)

Automotive: Sirens/Switches

Safety First

This document provides all the necessary information to allow your Whelen product to be properly and safely installed. Before beginning the installation and/or operation of your new product, the installation technician and operator must read this manual completely. Important information is contained herein that could prevent serious injury or damage.

- **Proper installation of this product requires the installer to have a good understanding of automotive electronics, systems and procedures.**
- **If mounting this product requires drilling holes, the installer MUST be sure that no vehicle components or other vital parts could be damaged by the drilling process. Check both sides of the mounting surface before drilling begins. Also de-burr any holes and remove any metal shards or remnants. Install grommets into all wire passage holes.**
- **If this manual states that this product may be mounted with tape or Velcro™, clean the mounting surface with a 50/50 mix of isopropyl alcohol and water and dry thoroughly.**
- **Do not install this product or route any wires in the deployment area of your air bag. Equipment mounted or located in the air bag deployment area will damage or reduce the effectiveness of the air bag, or become a projectile that could cause serious personal injury or death. Refer to your vehicle owners manual for the air bag deployment area. The User/Installer assumes full responsibility to determine proper mounting location, based on providing ultimate safety to all passengers inside the vehicle.**
- **For this product to operate at optimum efficiency, a good electrical connection to chassis ground must be made. The recommended procedure requires the product ground wire to be connected directly to the NEGATIVE (-) battery post.**
- **If this product uses a remote device to activate or control this product, make sure that this control is located in an area that allows both the vehicle and the control to be operated safely in any driving condition.**
- **Do not attempt to activate or control this device in a hazardous driving situation.**
- **It is recommended that these instructions be stored in a safe place and referred to when performing maintenance and/or reinstallation of this product.**
- **FAILURE TO FOLLOW THESE SAFETY PRECAUTIONS AND INSTRUCTIONS COULD RESULT IN DAMAGE TO THE PRODUCT OR VEHICLE AND/OR SERIOUS INJURY TO YOU AND YOUR PASSENGERS!**

For warranty information regarding this product, visit www.whelen.com/warranty

Important!!!

Installation of the Whelen Longhorn siren requires some vehicle modifications. The procedures outlined in this guide should only be performed by a qualified technician. Before proceeding with the installation, read this entire guide carefully!

Preparing the vehicle for installation (High Trim)...

1. Locate the lowest (air dam) section of the front bumper.
2. Remove the lower, center section of the air dam to accommodate the Longhorn grill. This is first accomplished by locating the centerline of the vehicle and measuring an area with a 19.5" width on center (High Trim /Fig.1) and a height of 3.125" (High Trim/Fig.2).
3. Carefully remove the section outlined in step 2. Make sure to radius the corners to .250" (see High Trim/Fig.1). Using the grill as a guide, trim the air dam for best fit around the grill.
4. Position the Longhorn grill into its mounting location. On High trim vehicles, you will see two rivets where the Longhorn grill mounts to the underside of the bumper. Remove these two rivets with a drill or other suitable tool.

Installing the Longhorn siren...

1. Remove the driver side front sway bar mounting bolt located between the sway bar and the grill. Repeat for passenger side sway bar mounting bolt.
2. Position the grill/horn assembly under the vehicle as shown. Now lift the assembly up and into its mounting location (see Assembly Drawings).

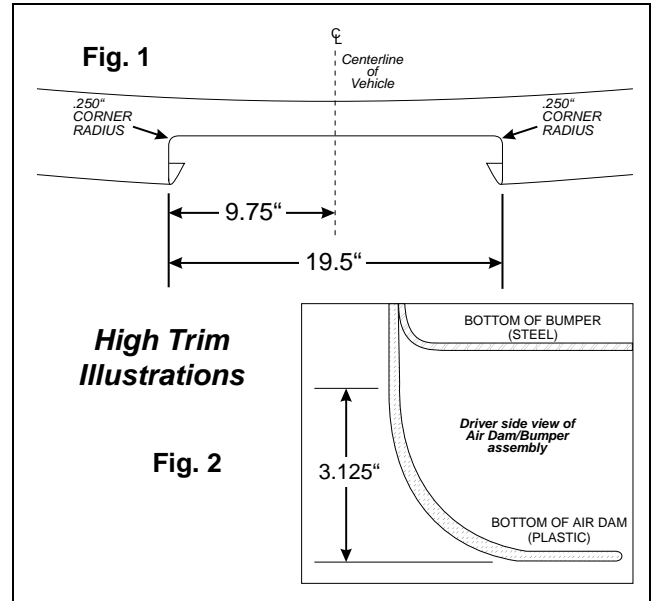

Note: When properly mounted, the horn assembly will come into direct contact the lower radiator air deflector. Although the horn will displace the deflector somewhat, this is normal.

3. Secure the assembly to the bumper using the provided hardware (see Assembly Drawings).
4. The sirens assemblies are now to be mounted onto the grill/horn as shown in the Assembly Drawings. Place the hose clamp onto the horn. Now insert the siren driver elbow into the horn. Do NOT tighten the hose clamp yet. Repeat procedure for the remaining siren driver.
5. Position the mounting plate under the sway bar mounting bracket and insert the bolt removed in step 1. Insert the special hex head bolt (provided) through the mounting plate and into the existing hole in the frame. Repeat for the remaining side.
6. Firmly tighten all mounting hardware and connect the siren wires to your siren amplifier (not included) as outlined in the siren amplifier instruction manual.

Note: For both types of Longhorn sirens, the wires coming from the siren driver assembly are labeled as follows:

WHITE Wire = Positive
BLACK Wire = Negative

Preparing the vehicle for installation (Low Trim)...

1. Locate the lowest (spoiler) section of the front bumper.
2. Remove the lower, center section of the spoiler to accommodate the Longhorn grill. This is first accomplished by locating the centerline of the vehicle and measuring an area with a 19.25" width on center (Low Trim/Fig.1).
3. Carefully remove the section outlined in step 2. Using the grill as a guide, trim the spoiler for best fit around the grill.
4. Position the Longhorn grill into its mounting location. There may be two rivets where the Longhorn grill mounts to the underside of the bumper. If these rivets are present remove them with a drill or other suitable tool.

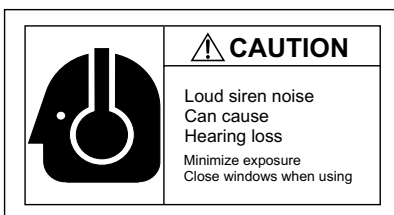
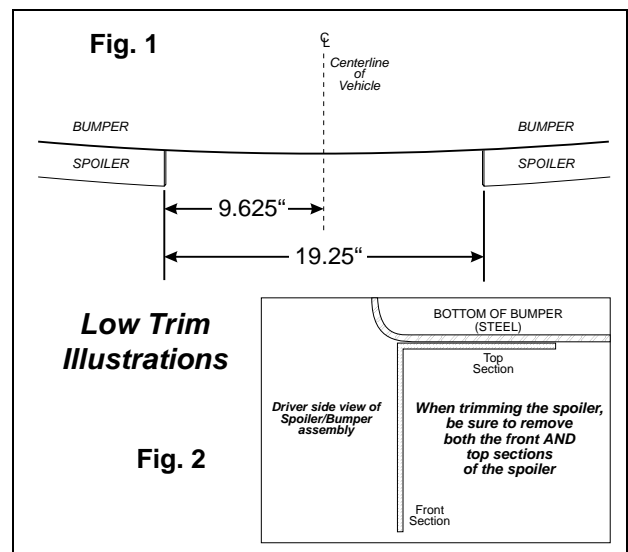

Assembly Drawing #1: Longhorn Installation (High Trim Vehicles)

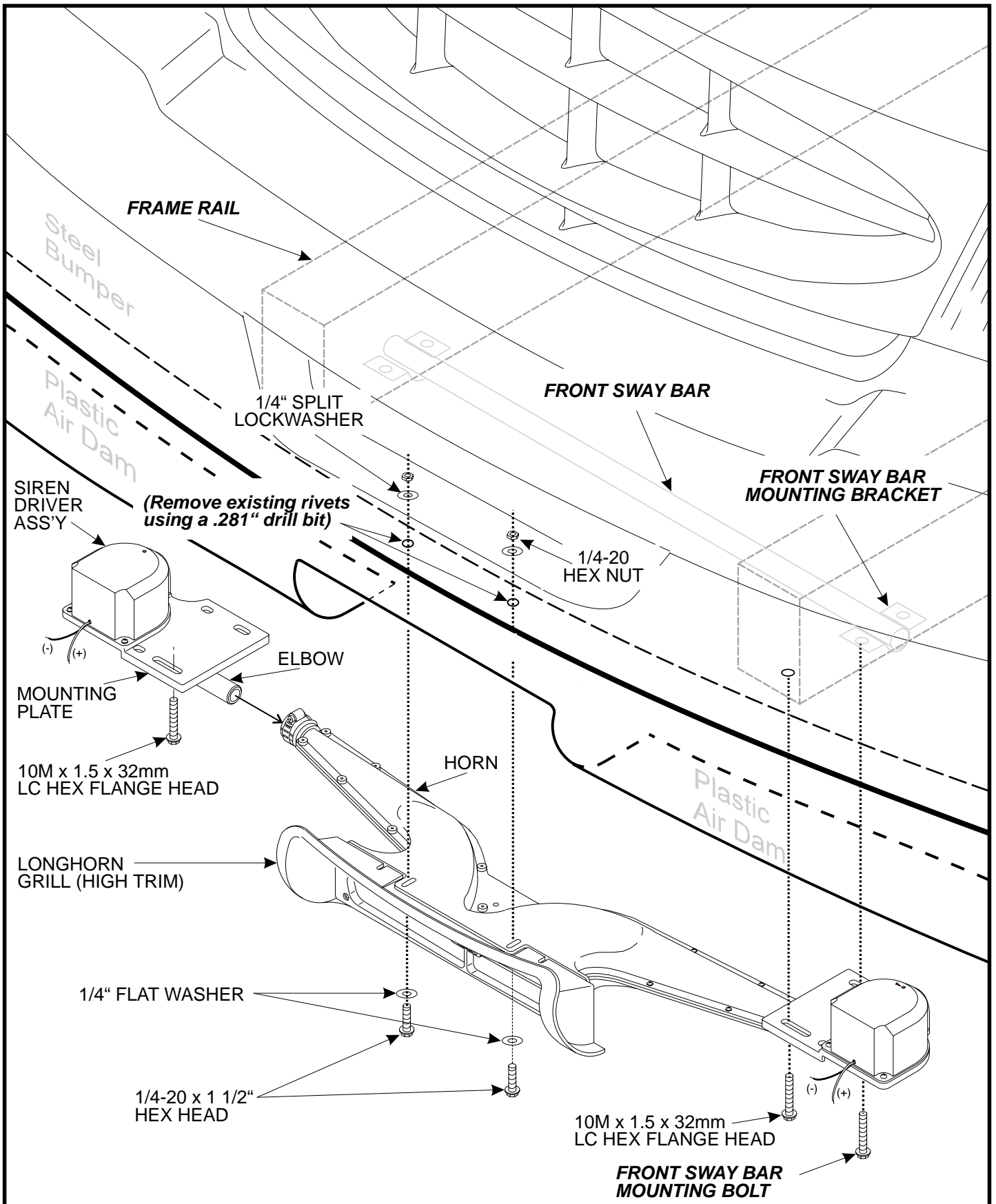

Assembly Drawing #2: Longhorn Installation (Low Trim Vehicles)

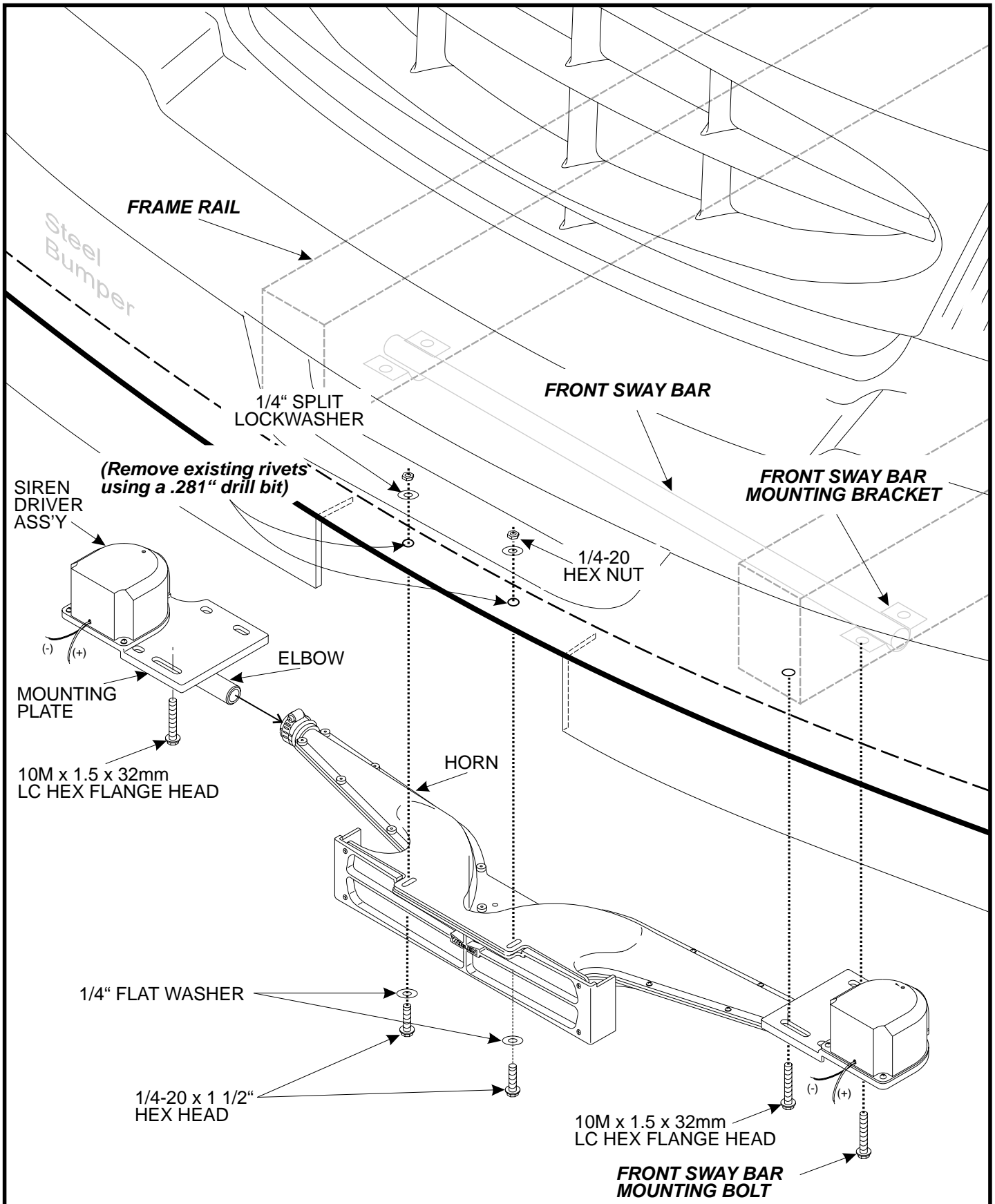

Longhorn Parts List (High Trim Vehicles)

<u>Qty</u>	<u>Description</u>	<u>Part Number</u>
1	Longhorn Grill (High Trim)	11-582685-000
1	Longhorn Grill (High Trim), Polished (replaces standard grill)	11-582685-001
1	Snow and Bug Screen	11-161527-010
1	Horn Assembly	72-1561479-00
2	SD-210R 100 watt Siren Driver	43-0263146-00
2	Siren Elbow	72-6261628-02
2	Siren Driver Cover	11-280566-000
1	Mounting Plate (Passenger Side)	07-281673-000
1	Mounting Plate (Driver Side)	07-281674-000
2	1-3/4" Hose Clamp	19-311599-000
2	10M x 1.5 x 32mm Hex Flange Head Bolt <i>(identical to front sway bar mounting bolt)</i>	14-M32E30-323

Longhorn Parts List (Low Trim Vehicles)

<u>Qty</u>	<u>Description</u>	<u>Part Number</u>
1	Longhorn Grill (Low Trim)	11-581869-000
1	Longhorn Grill (Low Trim), Polished (replaces standard grill)	11-581869-001
1	Snow and Bug Screen	11-161527-010
1	Horn Assembly	72-1561479-00
2	SD-210R 100 watt Siren Driver	43-0263146-00
2	Siren Elbow	72-6261628-02
2	Siren Driver Cover	11-280566-000
1	Mounting Plate (Passenger Side)	07-281673-000
1	Mounting Plate (Driver Side)	07-281674-000
2	1-3/4" Hose Clamp	19-311599-000
2	10M x 1.5 x 32mm Hex Flange Head Bolt <i>(identical to front sway bar mounting bolt)</i>	14-M32E30-323