

ROUTE 145, WINTHROP ROAD
 CHESTER, CONNECTICUT 06412-0684
 TELEPHONE: (860) 526-9504
 FAX: (860) 526-4078

Fig. 1

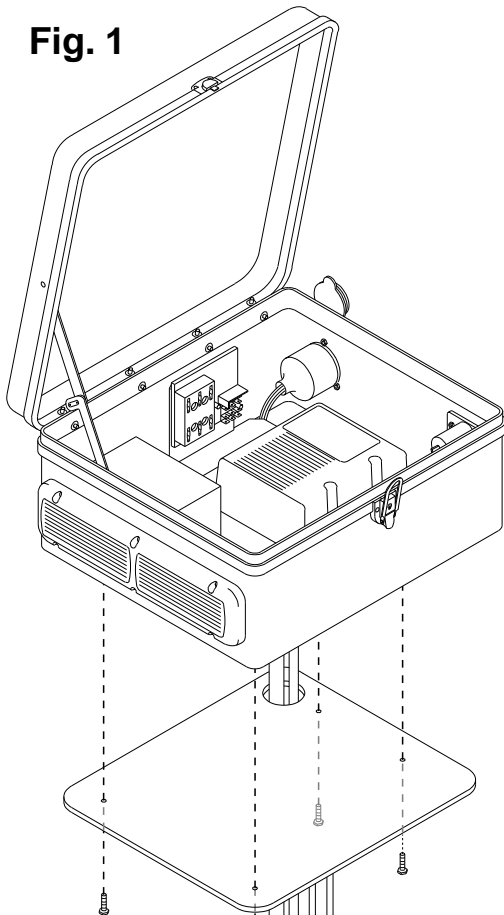

Mounting the Squad Fitters 6 Strobe Power Box...

1. Locate the mounting rack directly behind the motorcycle seat.
2. Drill four, 0.281" holes (see Drilling Guide) into the mounting rack. Make sure that the position of these mounting holes enable the strobe box to be mounted so that the harness opening in the bottom of the box is directly over the access hole in the mounting rack.
3. Feed all of the cables that come from the strobe box through the harness opening in the mounting rack.
4. Mount the strobe box on the mounting rack using the supplied hardware.

Wiring the Squad Fitters Strobe Power Box...

1. Under the seat, locate the siren assembly harness. This free harness bundle consists of 2 (two) PINK wires, 2 (two) YELLOW wires, 1 (one) YELLOW w/RED wire, 1 (one) BLACK w/ YELLOW wire and 1 (one) WHITE w/BLACK wire.
2. Route the 4 conductor (WHITE, GREEN, BLACK & RED) harness from the Power Box to the siren assembly harness and connect as shown in Fig. 1.
3. Route the 5 conductor (RED, WHITE, BLACK, BROWN & GREEN) harness from the Power Box to the pursuit relay circuit and connect as shown in Fig. 1. Be sure that the unused wires are cut and capped.
4. Extend the 2 conductor (BLACK & WHITE) harness from the Power Box to the 100 watt speaker (customer supplied) and connect as shown in Fig. 1.
5. Extend the RED and BLACK wires from the Power Box to the motorcycle battery and connect as shown.
6. Extend strobe cables from the front remote strobes, up through the mounting rack and into the Power Box. Plug the strobe cables into the available outlets (Outlets 1&3 and 2&4 flash simultaneously, while 1&2 and 3&4 alternate).

