

Route 145, Winthrop Road
Chester, CT 06412-0684
TELEPHONE: (860) 526-9504
TOLL FREE: 1-800-637-4736
FACSIMILE: (860) 526-4784

COYOTE SERIES CENTRAL COMMUNICATIONS DEVICE

CDCBAC, 115/220 VOLTS AC, AUDIO OUTPUT

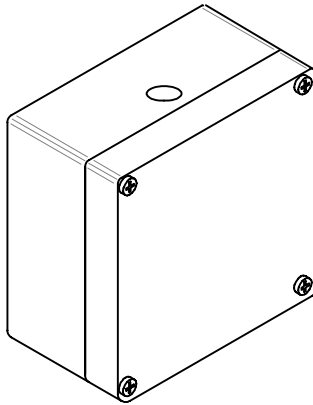

SPECIFICATIONS

Voltage:	115/220 VAC, 50/60 Hz
Standby Current:	.04 Amps, typical
Active Current:	.1 Amps, typical
Weight:	6 lbs. (2.7 kg)
Size:	4" x 7" x 7"

Description

The COYOTE™ Series of audible alerting devices are ideally suited for industrial applications where high quality, high output audible warning is required.

The COYOTE™ **Central Communications Device**, Model CDCBAC, is intended to be a common control unit for one or more remote amplified speakers. A **Central Device** features 19 different selections, including, a Cancel and two field programmed Digital Voice messages. In addition, the CDCBAC can interface with an existing Paging system, to further enhance in plant warning capabilities.

The **Central Device** is easy to install and easy to configure. Four different tones may be selected through simple switch settings. Activation is as simple as supplying a contact closure to a pair of input terminals. The output audio level is adjusted by setting a potentiometer. The Paging input has a separate volume adjustment, so that warning tone levels and paging levels may be set independently. The audio output is a 600 Ω transformer isolated signal.

Installation

A COYOTE™ **Central Device** does not require any special tools or training to install and operate, however, it must be installed and tested in accordance with all local electrical codes and regulations.

1. Remove four cover screws and remove the cover.
2. Mount the unit to the mounting surface using four appropriate screws (not supplied).

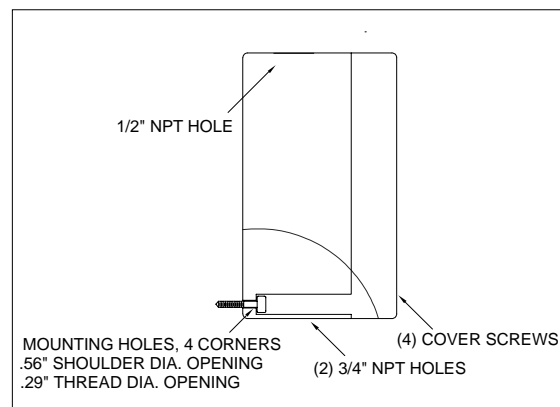

3. Route the AC wiring through the right-hand 3/4" NPT hole in the bottom of the unit. Route the control and paging wires through the left-hand 3/4" NPT hole. (Cable clamps are not supplied).

4. Use wire nuts to connect the AC service. The BLACK wire is Hot, the WHITE wire is Neutral. Connect the service ground to the large brass screw near the knockouts.

5. Connect a Normally Open contact closure between the desired tone and one of the RTN terminals. If all four tones are in use, more than one wire may be installed in each RTN terminal. **Connecting the same closure to more than one COYOTE™ unit may introduce an undesirable ground loop condition.** Separate closures are recommended.

6. Select the tone by setting the rotary switch that corresponds to the Input Terminals. For example, the leftmost Tone Selection Switch (marked Input 1 on the drawing below) corresponds to the leftmost Input Terminal (marked 1 below.). The tones are described in the Table. Note that the tone selection number may vary from switch to switch.

7. Set the **Input 1 Timing Jumper**. If the jumper is installed, Tone 1 will time out after 3 minutes, with

jumper 1 removed, Tone 1 will follow the contact closure at Input Terminal 1. Tones 2, 3 and 4 always follow their respective closures.

8. Most tones (see Table) include a 10 second Ramp Up period, to full output power. The **Ramp Up Jumper** enables or disables this feature for all tones.

9. Route the Audio Output through the 1/2" NPT hole on top of the box. Make the audio connections with wire appropriate for the application.

**CAUTION:
HEARING PROTECTION MAY BE REQUIRED
DURING STEPS 10, 11 AND 12.**

10. Set the **Output Level** to midrange by adjusting the potentiometer. Apply power. Activate a tone and set the speaker volume. If the output sounds distorted, lower the **Output Level** and re-adjust the speaker taps or the COYOTE™ remote Amplifier setting.

11. Connect the **Paging Input** if used. Set the **Paging Level** by adjusting the potentiometer. This setting should be made after the **Output Level** is set.

12. Install the cover and test the set up.

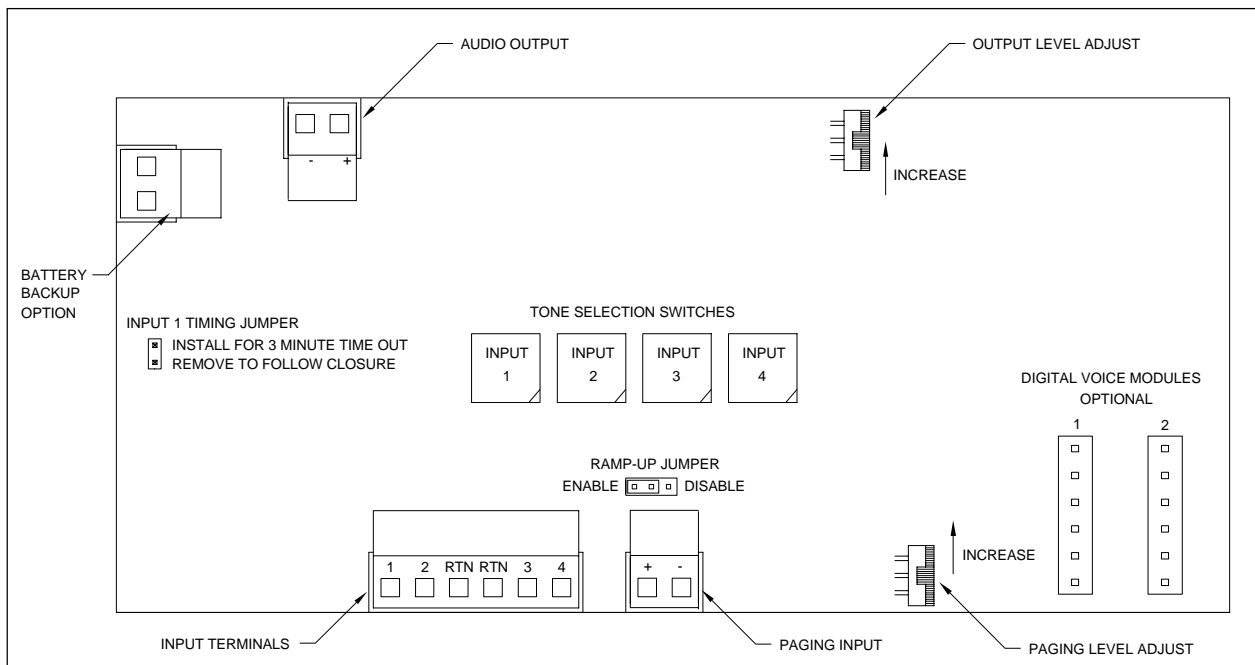

TONE SELECTION TABLE

INPUT #1 TONE SELECTED BY SWITCH SETTING SW1	INPUT #2 TONE SELECTED BY SWITCH SETTING SW2	INPUT #3 TONE SELECTED BY SWITCH SETTING SW3	INPUT #4 TONE SELECTED BY SWITCH SETTING SW4
SW1-0 = WAIL	SW2-0 = WAIL	SW3-0 = HI-LO	SW4-0 = BELL
SW1-1 = YELP	SW2-1 = YELP	SW3-1 = BELL	SW4-1 = YEOW
SW1-2 = HI-LO	SW2-2 = HI-LO	SW3-2 = YEOW	SW4-2 = HORN
SW1-3 = BELL	SW2-3 = BELL	SW3-3 = HORN	SW4-3 = BEEP
SW1-4 = YEOW	SW2-4 = YEOW	SW3-4 = BEEP	SW4-4 = STUTTER
SW1-5 = HORN	SW2-5 = HORN	SW3-5 = STUTTER	SW4-5 = BING-BONG
SW1-6 = BEEP	SW2-6 = BEEP	SW3-6 = BING-BONG	SW4-6 = NFPA WHOOP
SW1-7 = STUTTER	SW2-7 = STUTTER	SW3-7 = NFPA WHOOP	SW4-7 = WESTMINSTER
SW1-8 = BING-BONG	SW2-8 = BING-BONG	SW3-8 = WESTMINSTER	SW4-8 = AIR HORN
SW1-9 = NFPA WHOOP	SW2-9 = NFPA WHOOP	SW3-9 = AIR HORN	SW4-9 = THREE TONE
SW1-A = WESTMINSTER	SW2-A = WESTMINSTER	SW3-A = THREE TONE	SW4-A = HI-LO TYPE-2
SW1-B = AIR HORN	SW2-B = AIR HORN	SW3-B = HI-LO TYPE-2	SW4-B = WARBLE
SW1-C = THREE TONE	SW2-C = THREE TONE	SW3-C = WARBLE	SW4-C = DIGITAL VOICE #1
SW1-D = HI-LO TYPE-2	SW2-D = HI-LO TYPE-2	SW3-D = DIGITAL VOICE #1	SW4-D = DIGITAL VOICE #2
SW1-E = WARBLE	SW2-E = WARBLE	SW3-E = DIGITAL VOICE #2	SW4-E = CANCEL
SW1-F = DIGITAL VOICE #1	SW2-F = DIGITAL VOICE #2	SW3-F = CANCEL	SW4-F = PULSED AIR HORN

TONE DESCRIPTIONS

WAIL	560-1050 Hz, up and down sweep, 11 sweeps per minute
YELP	560-1050 Hz, up and down sweep, 200 sweeps per minute
HI-LO	560 Hz and 760 Hz, alternating, 1 second per cycle
BELL	800 Hz, percussive strike, damping to zero level, no Ramp Up
YEOW	1295-560Hz, descending sweep, 36 sweeps per minute
HORN	470 Hz, steady tone
BEEP	470 Hz, slow intermittent, 75 cycles per minute
STUTTER	470 Hz, fast intermittent, 300 cycles per minute
BING-BONG	880 Hz and 690 Hz, percussive, damping to zero level, 30 cycles per minute, no Ramp Up
NFPA WHOOP	425-775 Hz, slow low to high sweep, 15 sweeps per minute
WESTMINSTER	Musical tone, no Ramp Up
AIR HORN	400 Hz and 800 Hz, steady tone
THREE TONE	636 Hz, 800 Hz, 636 Hz, 475 Hz, 20 cycles per minute
HI-LO, TYPE 2	360 Hz and 520 Hz, alternating, 60 cycles per minute
WARBLE	560-1050 Hz, rapid up and down sweep, 6 sweeps per second
PULSED AIR HORN	400 Hz and 800 Hz, 24 cycles per minute
DIGITAL VOICE 1	Field recorded message, 20 seconds maximum, Note 1
DIGITAL VOICE 2	Field recorded message, 20 seconds maximum, Note 1
CANCEL	Terminates active tone, Note 2

Note 1 - A short Bell tone precedes all Digital Voice messages. There is no Ramp Up feature for Digital Voice messages. Messages automatically repeat, without the Bell tone. Digital Voice modules are individual options.

Note 2 - Activating any new tone will cancel a presently active tone.

