

PRODUCT DESCRIPTION

Model WS15, LOUDSPEAKER ASSEMBLY

Part # 01-1461893-00

Doc. # 04-0113164-00

GENERAL

Whelen Model WS15 is a 15 watt speaker intended for use in personnel warning applications.

The speaker consists of all metal construction. All exposed metal parts are gray baked epoxy finished, to eliminate corrosion. The speaker incorporates a high efficiency double re-entrant loudspeaker.

The WS15 comes with a swivel mounting base that allows for vertical and horizontal positioning with a single adjustment. The base is easily attached to a number of surfaces, such as I-beams or pillars.

INSTALLATION

Determine the location of the speaker and mount the speaker. Use the mounting foot detail below, for either three mounting screws or for strapping.

Connect the speaker cable to the speaker driver. Notice that the terminals are marked 1 and 2. Speaker connections are:

Speaker (+) wire to Terminal 1

Speaker (-) wire to Terminal 2

Dimensions

Width: 8.0" (20.3 cm)

Height: 8.0" (20.3 cm)

Depth: 9.0" (22.9 cm)

Weight 4 lbs. (1.9 kg)

Finish

Gray, baked epoxy

Performance

SPL: 15 W 116 dBA (at 4 ft., 500 Hz)

Dispersion: 110 °

Measurement based on Whelen Amplifier 01-0285564-00C.

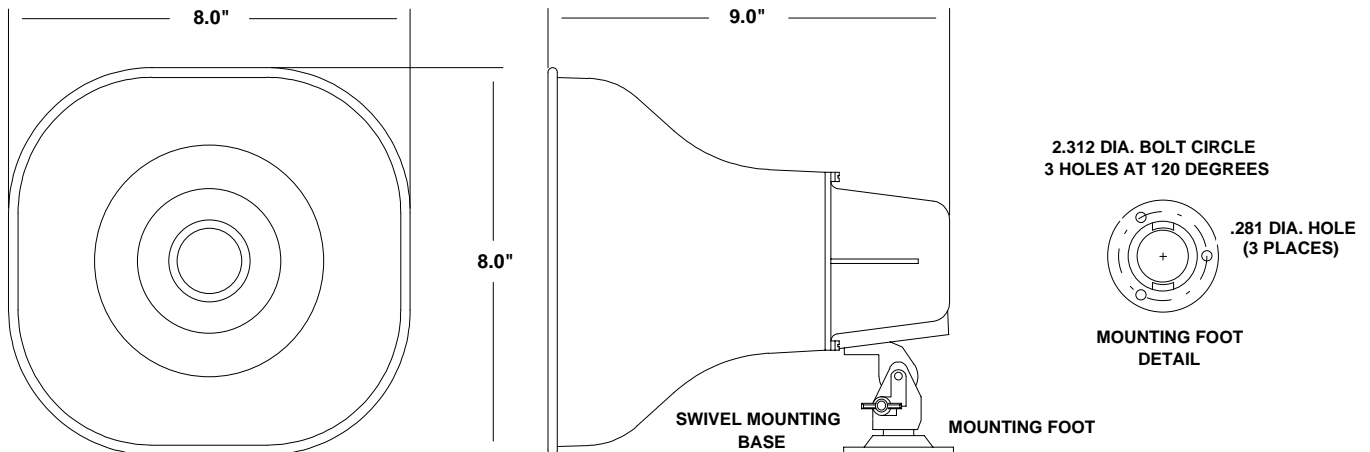

PIONEERS IN WARNING SIGNALS
WHELEN®

ENGINEERING COMPANY, INC.

Route 145, Winthrop Rd., Chester, CT 06412-0684

Tel.: (800) 63 SIREN Fax: (860) 526-4784