

# WHELEN<sup>®</sup>

ENGINEERING COMPANY INC.

51 Winthrop Road  
Chester, Connecticut 06412-0684  
Phone: (800) 63SIREN  
Phone: (860) 526-9504  
Fax: (860) 526-4784  
Internet: [www.whelen.com](http://www.whelen.com)  
Sales e-mail: [iowsales@whelen.com](mailto:iowsales@whelen.com)  
Customer Service e-mail: [iowserv@whelen.com](mailto:iowserv@whelen.com)

Model WS15T Loudspeaker Assembly  
P/N: 01-1461234-00

## GENERAL

Whelen Model WS15T is a 15 watt speaker intended for use in personnel warning applications.

The speaker consists of all metal construction. All exposed metal parts are grey baked epoxy finished, to eliminate corrosion. The speaker incorporates a high efficiency double re-entrant loudspeaker.

An internal impedance matching transformer allows the user to select reduced output power levels.

## INSTALLATION

The WS15T comes with a swivel mounting base that allows for vertical and horizontal positioning with a single adjustment.

Determine the location of the speaker and mount the speaker. Use the mounting foot detail below, for either screws or strapping.

Connect the speaker cable to the speaker driver. Notice that the terminals are marked 1 and 2. Speaker connections are:

Speaker (+) wire to Terminal 1  
Speaker (-) wire to Terminal 2

## Dimensions

Height: 8.0" (20.3 cm)  
Width: 8.0" (20.3 cm)  
Depth: 9.0" (22.9 cm)  
Weight: 4.0 lbs. (1.9 kg)  
Finish: Grey, baked epoxy

Dispersion: 100°

## Performance (at 4 ft., 500 Hz)

SPL:	Tap	Watts	dBA
	1	0.9	103
	2	1.8	107
	3	3.8	110
	4	7.5	113
	5	15	116
	6	Do Not Use	
	7	Do Not Use	

Measurement based on Whelen Amplifier 01-0285564-00C

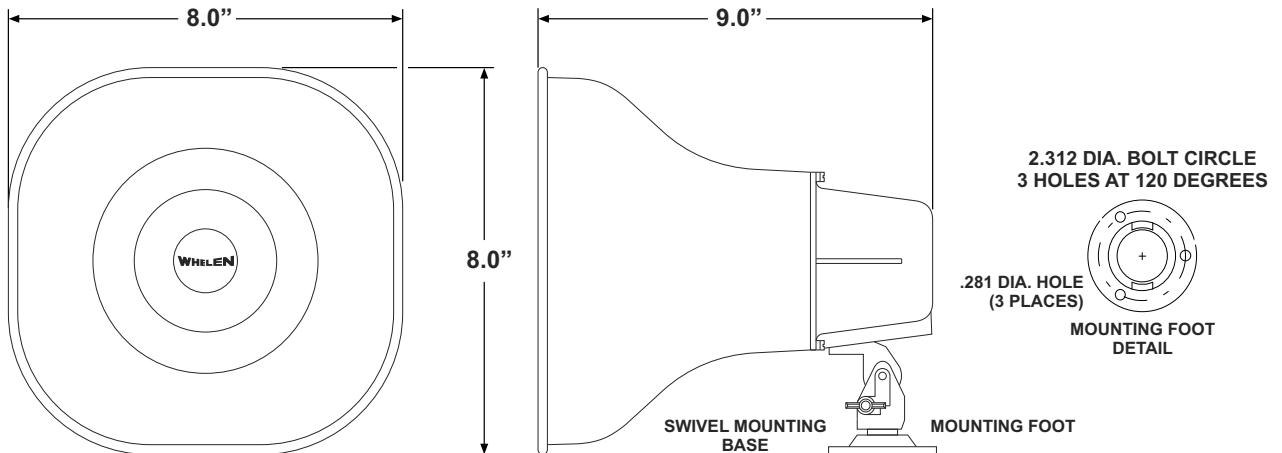

**For warranty information regarding this product, visit [www.whelen.com/warranty](http://www.whelen.com/warranty)**