

WHELEN[®]

ENGINEERING COMPANY INC.

Route 145, Winthrop Road,
Chester, Connecticut 06412

Phone: (860) 526-9504

Fax: (860) 526-4078

Internet: www.whelen.com

Sales e-mail: autosale@whelen.com

Canadian Sales e-mail: autocan@whelen.com

Customer Service e-mail: custserv@whelen.com

Installation Guide: UPS64LX Strobe Power Supply

Safety First

This document provides all the necessary information to allow your Whelen product to be properly and safely installed. Before beginning the installation and/or operation of your new product, the installation technician and operator must read this manual completely. Important information is contained herein that could prevent serious injury or damage.

- **Proper installation of this product requires the installer to have a good understanding of automotive electronics, systems and procedures.**
- **If mounting this product requires drilling holes, the installer MUST be sure that no vehicle components or other vital parts could be damaged by the drilling process. Check both sides of the mounting surface before drilling begins. Also de-burr any holes and remove any metal shards or remnants. Install grommets into all wire passage holes.**
- **If this manual states that this product may be mounted with tape or Velcro™, clean the mounting surface with a 50/50 mix of isopropyl alcohol and water and dry thoroughly.**
- **Do not install this product or route any wires in the deployment area of your air bag. Equipment mounted or located in the air bag deployment area will damage or reduce the effectiveness of the air bag, or become a projectile that could cause serious personal injury or death. Refer to your vehicle owners manual for the air bag deployment area. The User/Installer assumes full responsibility to determine proper mounting location, based on providing ultimate safety to all passengers inside the vehicle.**
- **For this product to operate at optimum efficiency, a good electrical connection to chassis ground must be made. The recommended procedure requires the product ground wire to be connected directly to the NEGATIVE (-) battery post.**
- **If this product uses a remote device to activate or control this product, make sure that this control is located in an area that allows both the vehicle and the control to be operated safely in any driving condition.**
- **Do not attempt to activate or control this device in a hazardous driving situation.**
- **It is recommended that these instructions be stored in a safe place and referred to when performing maintenance and/or reinstallation of this product.**
- **FAILURE TO FOLLOW THESE SAFETY PRECAUTIONS AND INSTRUCTIONS COULD RESULT IN DAMAGE TO THE PRODUCT OR VEHICLE AND/OR SERIOUS INJURY TO YOU AND YOUR PASSENGERS!**

Selecting a mounting location...

The most common choice for a mounting area would be a trunk or similar compartment. However, due to the wide variety of vehicles onto which the UPS64LX could be installed, this is not always possible. The following guidelines will help the installer select an acceptable alternative:

- A) The UPS64LX should be mounted on a metal surface to aid heat dissipation. Be sure that this surface is not one that either generates or is exposed to excessive heat during normal operation of the vehicle.
- B) Do not select a location where the UPS64LX will be exposed to potential damage from any unsecured or loose equipment in the vehicle.
- C) Be sure the area selected will not allow the UPS64LX to be exposed to water!
- D) When routing the UPS64LX's wires, it is important to choose a path that will keep these wires away from excessive heat and from any vehicle equipment that could compromise the integrity of the wires (ex. trunk lids, door jams, etc.).
- E) When the best mounting location has been determined, securely fasten the UPS64LX to its mounting surface using the supplied hardware.

DANGER! The Strobe Light Power Supply is a high voltage device. Do not touch or remove tube assembly in strobe light head assemblies while in operation. Wait 10 minutes after disconnecting the unit from its power source before starting work or troubleshooting on power supply or system.

CAUTION: As it will be necessary to drill holes into the mounting surface, the installer MUST be sure that no vehicle components or other vital parts could be damaged by the drilling process. Check both sides of the mounting surface before drilling begins!

1. Position the UPS64LX in its proposed mounting location to ensure that it fits properly. With the UPS64LX in place, insert an awl or other suitable

tool into the mounting screw area of the power supply and scribe the areas that are to be drilled.

2. Remove the UPS64LX from its mounting area and, using a drill bit sized for a #10 sheet metal screw, drill a hole in each of the areas scribed in the previous step.
3. Return the UPS64LX to its mounting location and using the supplied #10 sheet metal screws, mount the UPS64LX onto its mounting surface.

Wiring your UPS64LX...

1. Locate the 3 position **Power Connector** included with your UPS64LX and plug it into the port indicated in Fig. 1. Extend the BLK and RED wires from the **Power Connector** towards the battery.

WARNING: All customer supplied wires, that connect to the positive (+) terminal of the battery, must be sized to supply at least 125% of the maximum operating current, and fused "at the battery" to carry the load!

2. Connect the RED wire to a fuse block (customer supplied) and then to the POSITIVE terminal on the battery.

NOTE! Although a 15 amp fuse (customer supplied) is required to be used in the fuse block, do not install the fuse until all of the wire connections are completed.

3. Connect the BLK wire to the factory chassis ground adjacent to the battery.

4. Refer to Fig. 2 for wiring information for the **Control Connector** and for the **Pattern Selection Connector**.

5. As indicated in Fig. 2, there is a provision in the **Power Connector** for a wire (VIO) to activate Hi Power/Low Power strobe operation. If this feature is desired, locate the VIO wire included with your power supply and, with the **Power Connector** disconnected from the power supply, insert the pinned end of the VIO wire into position 3 of the **Power Connector**. Refer to Fig. 2 for wiring information.

Pattern Selection Connector

- Pos. 1 WHT/RED
- Pos. 2 BRN
- Pos. 3 WHT

NOTE - The WHITE/RED wire in the Pattern Selection Connector provides positive voltage designed to be used to supply power to your switches. This wire is internally protected to 250 ma. If a short circuit occurs, the circuit will interrupt current flow until the short has been removed.

Control Connector

- Pos. 1 No Wire
- Pos. 2 GRN
- Pos. 3 BLU

Power Connector

- Pos. 1 RED
- Pos. 2 BLK
- Pos. 3 VIO (Optional)

Switch Operation Table

Pattern Control (Switches 1 & 2)

Switches 1&2 Disabled	Comet Flash Pattern
Switch 1 Enabled	Double Flash Pattern
Switch 2 Enabled	Single Flash Pattern
Switches 1&2 Enabled	Action Flash Pattern

Outlet Control (Switches 3 & 4)

Switch 3 Enabled	Outlets 2 & 3 Active
Switch 4 Enabled	Outlets 1 & 4 Active
Switches 3&4 Enabled	All Outlets Active

Fig. 1

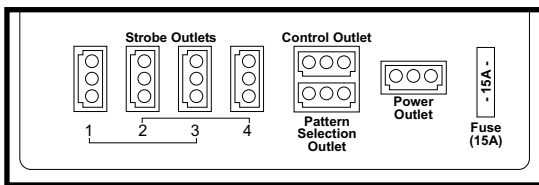

Simultaneous Outlets
 Outlets 1 & 3 - Simultaneously Flash
 Outlets 2 & 4 - Simultaneously Flash

Alternating Outlets
 Outlets 1 & 4 - Alternately Flash
 Outlets 2 & 3 - Alternately Flash

Fig. 2

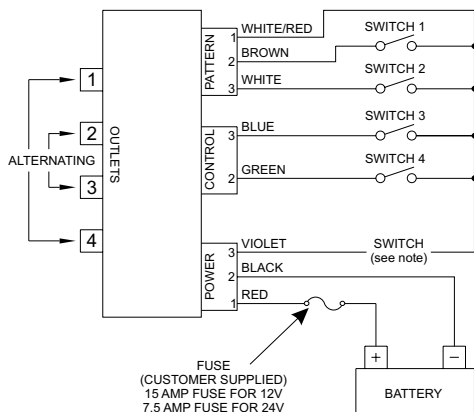

UPS64LX SPECIFICATIONS:

Input Voltage	-	13.5 VDC (26.5 VDC) ± 20%
Input Current (4 Lamps)	-	7 AMPS (4AMPS)
Input Current (2 Lamps)	-	4 AMPS (2.5 AMPS)
Output Power (4 Lamps)	-	75 Watts
Output Power (2 Lamps)	-	40 Watts
V Ctrl	-	13.5 VDC (26.5 VDC) ± 20%
I Ctrl	-	100 ma (MAX)
V Output Ctrl	-	13.5 VDC (26.5 VDC) ± 20%
I Output Ctrl	-	20 ma (MAX)
V Pattern Ctrl	-	13.5 VDC (26.5 VDC) ± 20%
I Pattern Ctrl	-	5 (MAX)
Comet Flash®		
Flashrate (Per Lamp)	-	75 CFPM @ 80 ms
Double Flash		
Flashrate (Per Lamp)	-	120 DFPM @ 80 ms
Single Flash		
Flashrate (Per Lamp)	-	220 SFPM
Action Flash	-	3 CYCLES COMET FLASH
	-	6 CYCLES SINGLE FLASH

NOTE - The type of switch used is dependant on how the operator wishes the Hi/Lo feature to function:

Latching Mode - By applying +voltage to the Violet wire for less than 1 sec., the power supply is "latched" into low power operation. The unit must be turned off and then back on to restore normal, Hi power operation. A momentary switch is desired for this style.

Level Mode - Applying +voltage to the Violet wire for more than 1 sec. holds the power supply in low power mode until that voltage is removed. A toggle switch is desired for this style.