

WHELEN[®]

ENGINEERING COMPANY INC.

Route 145, Winthrop Road,

Chester, Connecticut 06412

Phone: (860) 526-9504

Fax: (860) 526-4078

Internet: www.whelen.com

Sales e-mail: autosale@whelen.com

Canadian Sales e-mail: autocan@whelen.com

Customer Service e-mail: custserv@whelen.com

Installation Guide Edge Lightbars 941/942-series

Safety First

This document provides all the necessary information to allow your Whelen product to be properly and safely installed. Before beginning the installation and/or operation of your new product, the installation technician and operator must read this manual completely. Important information is contained herein that could prevent serious injury or damage.

- **Proper installation of this product requires the installer to have a good understanding of automotive electronics, systems and procedures.**
- **If mounting this product requires drilling holes, the installer MUST be sure that no vehicle components or other vital parts could be damaged by the drilling process. Check both sides of the mounting surface before drilling begins. Also de-burr any holes and remove any metal shards or remnants. Install grommets into all wire passage holes.**
- **If this product is mounted with tape or Velcro™, clean the mounting surface with a 50/50 mix of isopropyl alcohol and water and dry thoroughly.**
- **Do not install this product or route any wires in the deployment area of your air bag. Equipment mounted or located in the air bag deployment area will damage or reduce the effectiveness of the air bag, or become a projectile that could cause serious personal injury or death. Refer to your vehicle owners manual for the air bag deployment area. The User/Installer assumes full responsibility to determine proper mounting location, based on providing ultimate safety to all passengers inside the vehicle.**
- **For this product to operate at optimum efficiency, a good electrical connection to chassis ground must be made. The recommended procedure requires the product ground wire to be connected directly to the NEGATIVE (-) battery post.**
- **If this product uses a remote device to activate or control this product, make sure that this control is located in an area that allows both the vehicle and the control to be operated safely in any driving condition.**
- **Do not attempt to activate or control this device in a hazardous driving situation.**
- **This product contains either strobe light(s), halogen light(s), high-intensity LEDs or a combination of these lights. Do not stare directly into these lights. Momentary blindness and/or eye damage could result.**
- **Use only soap and water to clean the outer lens. Use of other chemicals could result in premature lens cracking (crazing) and discoloration. Lenses in this condition have significantly reduced effectiveness and should be replaced immediately. Inspect and operate this product regularly to confirm its proper operation and mounting condition. Do not use a pressure washer to clean this product.**
- **It is recommended that these instructions be stored in a safe place and referred to when performing maintenance and/or reinstallation of this product.**
- **FAILURE TO FOLLOW THESE SAFETY PRECAUTIONS AND INSTRUCTIONS COULD RESULT IN DAMAGE TO THE PRODUCT OR VEHICLE AND/OR SERIOUS INJURY TO YOU AND YOUR PASSENGERS!**

Mounting your Edge Lightbar

Refer to the Lightbar mounting guide included with your lightbar

Routing your Edge Lightbar Cable(s)

1. To protect the headliner from damage caused by drilling the cable access hole through the vehicle roof, allow a 5" to 7" distance between roof and headliner by lowering the headliner before drilling.
2. Using a 1" hole saw, drill the cable access hole.

NOTE: There may be a roof support member that spans the distance between the driver's and passenger's side. DO NOT DRILL THROUGH THIS MEMBER! Adjust the location until the hole can be drilled without contacting this support member.

3. Use a round file to smooth and de-burr the edges of the hole.
4. Insert a 1" grommet (user supplied) into the cable access hole.
5. Insert the cable(s) through the cable access hole into the vehicle. Use RTV silicone to weatherproof the access hole after the cable(s) are pulled completely into the vehicle.
6. Route the cable(s) down through the B-pillar. The cable(s) must make a 90° turn to enter the B-pillar. Although routing the cable in this manner may be difficult, this has been determined to be the best procedure. It is up to the installation technicians discretion whether to route the cable(s) as recommended or use an alternative route. Pull the full length of the cable(s) out of the hole at the base of the B-pillar (Fig. 1) and route towards your switch panel. Refer to the instructions included with your switches for switch wiring information.

NOTE: The outer surfaces of this product may be cleaned with mild soap and water. Use of any other chemicals may void product warranty. Do not use a pressure washer.

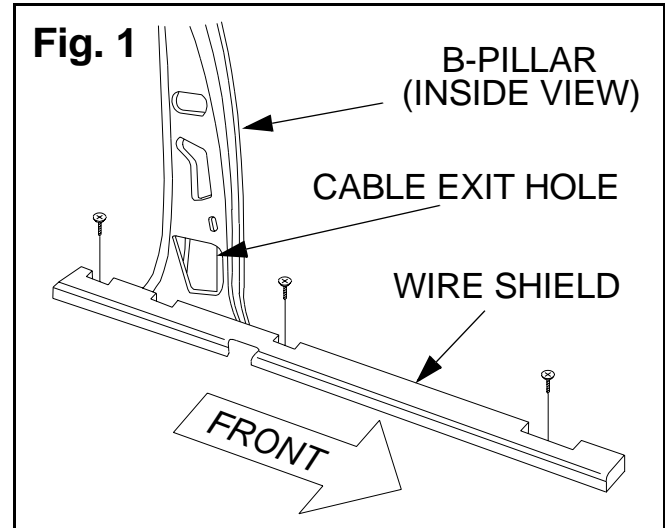
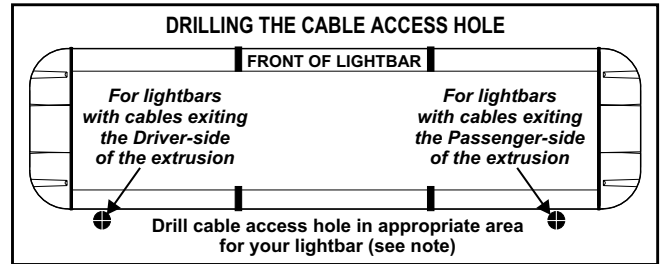

CONTROL CABLE

1. BROWN - Provides 12 VDC power for control wires.
2. GREEN - In the factory default configuration, this wire activate all forward facing strobes (Function 1).
3. GREY - In factory default configuration, this will activate all rear facing strobes (Function 2).
4. BLUE - In factory default configuration, this will activate both front and rear facing strobes (Function 3).
5. VIOLET - When applied to 12 VDC, this will initiate low power operation of all strobes. Lightbar must be turned off, then on again to restart in high power mode.
6. WHITE/BLUE - When activated, strobe flash pattern switches from Comet flash to double flash.
7. WHITE/VIOLET - When activated, strobe flash pattern switches from Comet flash to random flash.

POWER CABLE

1. RED - Provides power for all strobe lamps. Connect to POSITIVE battery terminal (12 VDC) and fuse @ 30 amps AT THE BATTERY.
2. BLACK - Provides ground for all strobe lamps. Connect to chassis ground.
3. RED/WHITE - Provides power for all halogen lamps. Connect to POSITIVE batter terminal (12 VDC) and fuse @ 30 amps AT THE BATTERY.
4. BLACK/WHITE - Provides ground for all halogen lamps. Connect to chassis ground.
5. NONE - RFI shield drain. Connect to chassis ground.

NOTE! Activating wires 6 and 7 simultaneously switches the strobe flash pattern from Comet Flash to Action Flash.

8. YELLOW - Activates passenger alley light.
9. WHITE - Activates driver alley light.
10. WHITE/BLACK - Activates front Take-Down lights.
11. WHITE/BROWN - Activates Rear Flasher (default).
12. WHITE/RED - Activates Front Flasher (default).
13. WHITE/ORANGE - Activates Center Option (default).
14. WHITE/YELLOW - Activates either Flashing Take-down or Steady Burn.
15. WHITE/GREEN - Activates Cruise Lights and/or Lighted Sign.
16. NONE - This is the RFI shield drain wire and is connected to ground.

LOW PRO CABLE (optional)

The Low Pro and Traffic Advisor cables are optional and may not be present on your particular lightbar. If these cables are present, refer to the instructional manuals for these options for wiring and operating information.

1. WHITE - Connect to POSITIVE siren terminal.
2. BLACK - Connect to NEGATIVE siren terminal.

TRAFFIC ADVISOR CABLE (optional)

This cable, if present, will plug into the rear of your Traffic Advisor control head.

941/942 Series Edge Lightbar

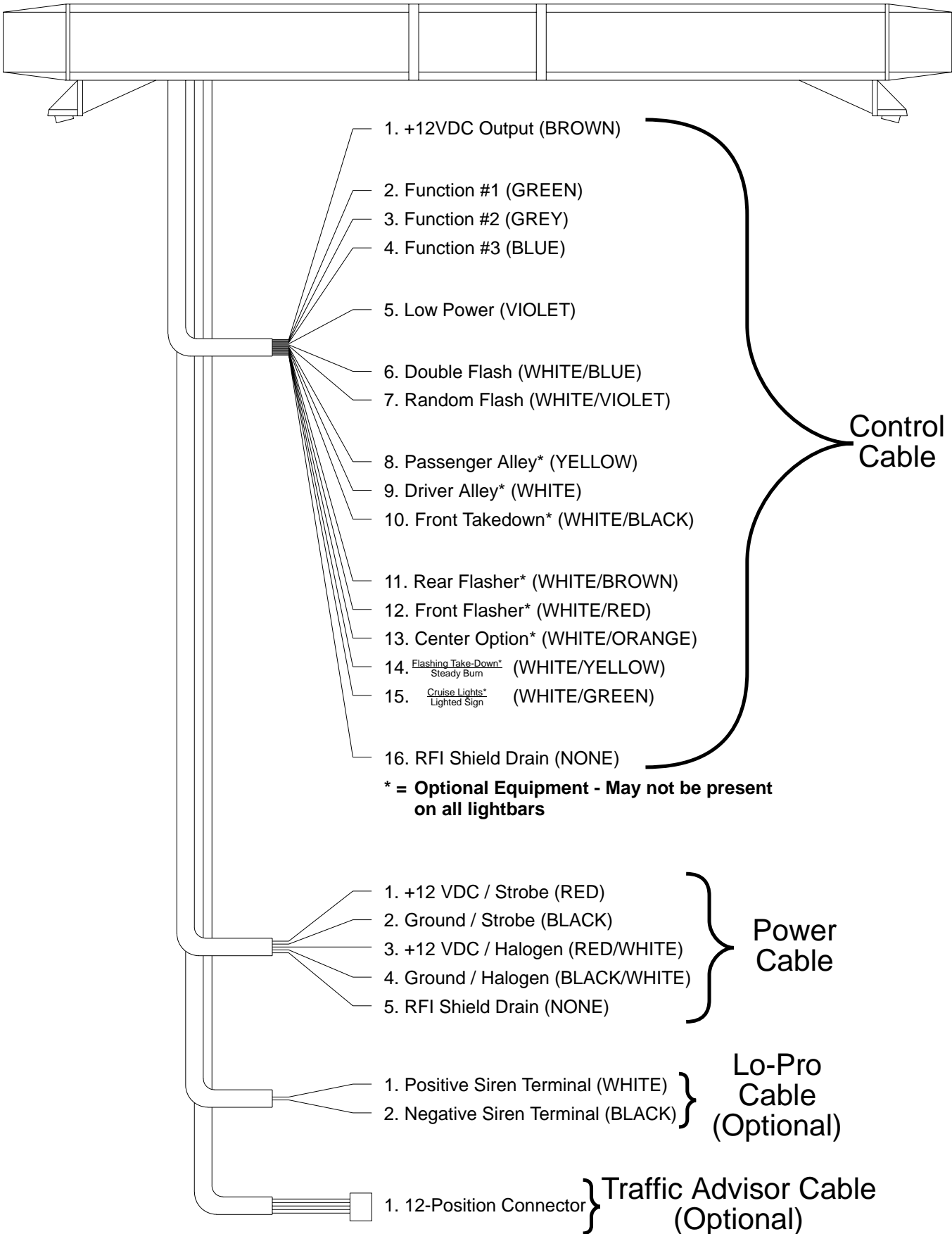

*** = Optional Equipment - May not be present on all lightbars**