

WHELEN[®]

ENGINEERING COMPANY INC.

51 Winthrop Road
Chester, Connecticut 06412-0684
Phone: (860) 526-9504
Fax: (860) 526-4078
Internet: www.whelen.com
Sales e-mail: autosale@whelen.com
Canadian Sales e-mail: autocan@whelen.com
Customer Service e-mail: custserv@whelen.com

Installation Guide: Model ISP94A Intelligent Strobe Power Supply

Safety First

This document provides all the necessary information to allow your Whelen product to be properly and safely installed. Before beginning the installation and/or operation of your new product, the installation technician and operator must read this manual completely. Important information is contained herein that could prevent serious injury or damage.

- **Proper installation of this product requires the installer to have a good understanding of automotive electronics, systems and procedures.**
- **If mounting this product requires drilling holes, the installer MUST be sure that no vehicle components or other vital parts could be damaged by the drilling process. Check both sides of the mounting surface before drilling begins. Also de-burr any holes and remove any metal shards or remnants. Install grommets into all wire passage holes.**
- **If this manual states that this product may be mounted with suction cups, magnets, tape or Velcro[®], clean the mounting surface with a 50/50 mix of isopropyl alcohol and water and dry thoroughly.**
- **Do not install this product or route any wires in the deployment area of your air bag. Equipment mounted or located in the air bag deployment area will damage or reduce the effectiveness of the air bag, or become a projectile that could cause serious personal injury or death. Refer to your vehicle owner's manual for the air bag deployment area. The User/Installer assumes full responsibility to determine proper mounting location, based on providing ultimate safety to all passengers inside the vehicle.**
- **For this product to operate at optimum efficiency, a good electrical connection to chassis ground must be made. The recommended procedure requires the product ground wire to be connected directly to the NEGATIVE (-) battery post.**
- **If this product uses a remote device to activate or control this product, make sure that this control is located in an area that allows both the vehicle and the control to be operated safely in any driving condition.**
- **Do not attempt to activate or control this device in a hazardous driving situation.**
- **It is recommended that these instructions be stored in a safe place and referred to when performing maintenance and/or reinstallation of this product.**
- **FAILURE TO FOLLOW THESE SAFETY PRECAUTIONS AND INSTRUCTIONS COULD RESULT IN DAMAGE TO THE PRODUCT OR VEHICLE AND/OR SERIOUS INJURY TO YOU AND YOUR PASSENGERS!**

For warranty information regarding this product, visit www.whelen.com/warranty

This ISP94A Intelligent Strobe Power Supply (hereafter collectively referred to as "ISP") can be installed in many different types of vehicles. The guidelines for the installation of this product are written so that no matter what vehicle is being used, the installation and operation of the ISP will be simple and straight forward.

Section 1: Selecting a mounting location

A good choice for a mounting area would be a trunk or similar compartment. However, due to the wide variety of vehicles onto which the ISP can be installed, this is not always possible. The following guidelines will help the installer select an acceptable alternative:

- **The ISP should be mounted on a metal surface to aid heat dissipation. Be sure that this surface is not one that either generates or is exposed to excessive heat during normal operation of the vehicle.**
- **Do not select a location where the ISP will be exposed to potential damage from any unsecured or loose equipment in the vehicle.**
- **Be sure the area selected will not allow the ISP to be exposed to water.**
- **When routing wires, it is important to choose a path that will keep them away from excessive heat and from any vehicle equipment that could compromise their integrity (ex. trunk lids, door jams, etc.).**
- **Be sure your mounting location does not block the cooling fan in the rear of the unit. (Fig. 1)**
- **When the best mounting location has been determined, securely fasten the ISP to its mounting surface using the supplied hardware.**

IMPORTANT! All customer supplied wires that connect to the positive terminal of the battery must be sized to supply at least 125% of the maximum operating current and **FUSED** at the battery to carry that load. **DO NOT USE CIRCUIT BREAKERS WITH THIS PRODUCT!**

WARNING! When extending the communication wires (BLUE & GREY), use either the Whelen 25ft cable (P/N 46-9641638250) or similar "twisted pair" wires.

Caution: As it will be necessary to drill holes into the mounting surface, the installer **MUST** be sure that no vehicle components or other vital parts could be damaged by the drilling process. Check both sides of the mounting surface before drilling begins.

Section 2: Operating Instructions:

The ISP has been designed to emulate the operations of four different types of power supplies:

Alternating Outlets Alt. 2X2
Simultaneous Outlets (by pairs) Simul. 2X2
Simultaneous Outlets Simul. 2X1X1
S.C. (Serial Communication). Custom

Select the desired operational mode by configuring dip switches 1, 2 & 5, located on the front panel of the power supply. The use of dip switches 3 & 4 is explained in the "Hi/Low Power" section.

The following will explain how to place the ISP into each of these respective modes, as well as outline the operational procedures for each mode.

Emulation Modes

Mode 1: Alternating Outlets (default configuration)

Dip Switches

Dip Switch configuration for Alternating Outlet Mode:

Dip Switch 1 - OFF

Dip Switch 2 - OFF

Dip Switch 5 - OFF

Control Wires

In this configuration, applying +12VDC to the control wires (using customer supplied switches) will have the following results:

Control Wire #1 = Outlets 1 & 2 enabled

Control Wire #2 = Outlets 3 & 4 enabled

Control Wire #3 = All Outlets enabled

Control Wire #4 = See Section 3: Hi/Low Power)

Flash Patterns: See Section 4.

Mode 2: Simultaneous Outlet Mode

Dip Switches

Dip Switch configuration for Simultaneous Outlet Mode:

Dip Switch 1 - ON

Dip Switch 2 - OFF

Dip Switch 5 - OFF

Control Wires

In this configuration, applying +12VDC to the control wires (using customer supplied switches) will have the following results:

Control Wire #1 = Outlets 1 & 3 enabled

Control Wire #2 = Outlets 2 & 4 enabled

Control Wire #3 = All Outlets enabled

Control Wire #4 = See Section 3: Hi/Low Power

Flash Patterns: See Section 4.

Mode 3: Simultaneous Mode

Dip Switches

Dip switch configuration for Simultaneous Mode:

- Dip Switch 1** - OFF
- Dip Switch 2** - ON
- Dip Switch 5** - OFF

Control Wires

In this configuration, applying +12VDC to the control wires (using customer supplied switches) will have the following results:

- Control Wire #1** = *Outlets 1 & 3 enabled*
- Control Wire #2** = *Outlet 2 enabled*
- Control Wire #3** = *Outlet 4 enabled*
- Control Wire #4** = *See Section 3: Hi/Low Power*

Flash Patterns: *See Section 4.*

Mode 4: S.C. (Serial Communication) Mode

NOTE: When the ISP is configured for S.C. mode, it is important to understand that the connections and operational procedures used are quite different from any of the other modes. In S.C. mode, CometFlash® is the only available pattern.

Dip Switches

S.C. emulation is accomplished by placing Dip Switch 5 in the ON position. At this point, the remaining Dip Switches (1 thru 4) are used to configure the address of the ISP for use in a S.C. system. The addressing properties function as follows:

To Configure Address 1:

- Dip Switch 1** - ON
- Dip Switch 2** - OFF
- Dip Switch 3** - OFF
- Dip Switch 4** - OFF
- Dip Switch 5** - ON

To Configure Address 3:

- Dip Switch 1** - OFF
- Dip Switch 2** - OFF
- Dip Switch 3** - ON
- Dip Switch 4** - OFF
- Dip Switch 5** - ON

To Configure Address 2:

- Dip Switch 1** - OFF
- Dip Switch 2** - ON
- Dip Switch 3** - OFF
- Dip Switch 4** - OFF
- Dip Switch 5** - ON

To Configure Address 4:

- Dip Switch 1** - OFF
- Dip Switch 2** - OFF
- Dip Switch 3** - OFF
- Dip Switch 4** - ON
- Dip Switch 5** - ON

Control Wires

In this configuration, control wires 1, 2, 3 & 4 are not used to enable outlets or control Hi/Low power activation, as with the previous modes. Outlet control and Hi/Low power activation is handled by the S.C. Multi-Purpose Controller.

Section 3: Hi/Low Power

Hi/Low power activation and functionality can be configured in any of 4 available modes, depending upon how Dip Switches 3 & 4 are positioned. Table 2 on Page 4 outlines each of the 4 configurations and their attributes. **NOTE:** In S.C. emulation mode, Hi/Low power activation is controlled with an S.C. Multi-Purpose Controller.

Section 4: Flash Patterns

The ISP can generate up to 8 flash patterns by activating the 4 Pattern Control wires, either individually or in combination. **NOTE:** in S.C. mode, CometFlash® is the only available pattern. Table 1 on page 4 outlines all of the available patterns and the wire activations needed to produce them.

Section 5: Diagnostix™ (Optional)

The optional Diagnostix™ display allows the operator to confirm proper operation of not only the 4 outlets on the ISP, but of the strobe light and strobe cable connected to these outlets as well. Each LED indicator on the Diagnostix™ display, provides diagnostic information for one outlet. For example; LED #1 monitors Outlet #1, etc. The LEDs appearance indicates the condition of it's corresponding outlet. Refer to Table 3 on Page 4.

ISP94A Wiring Diagram

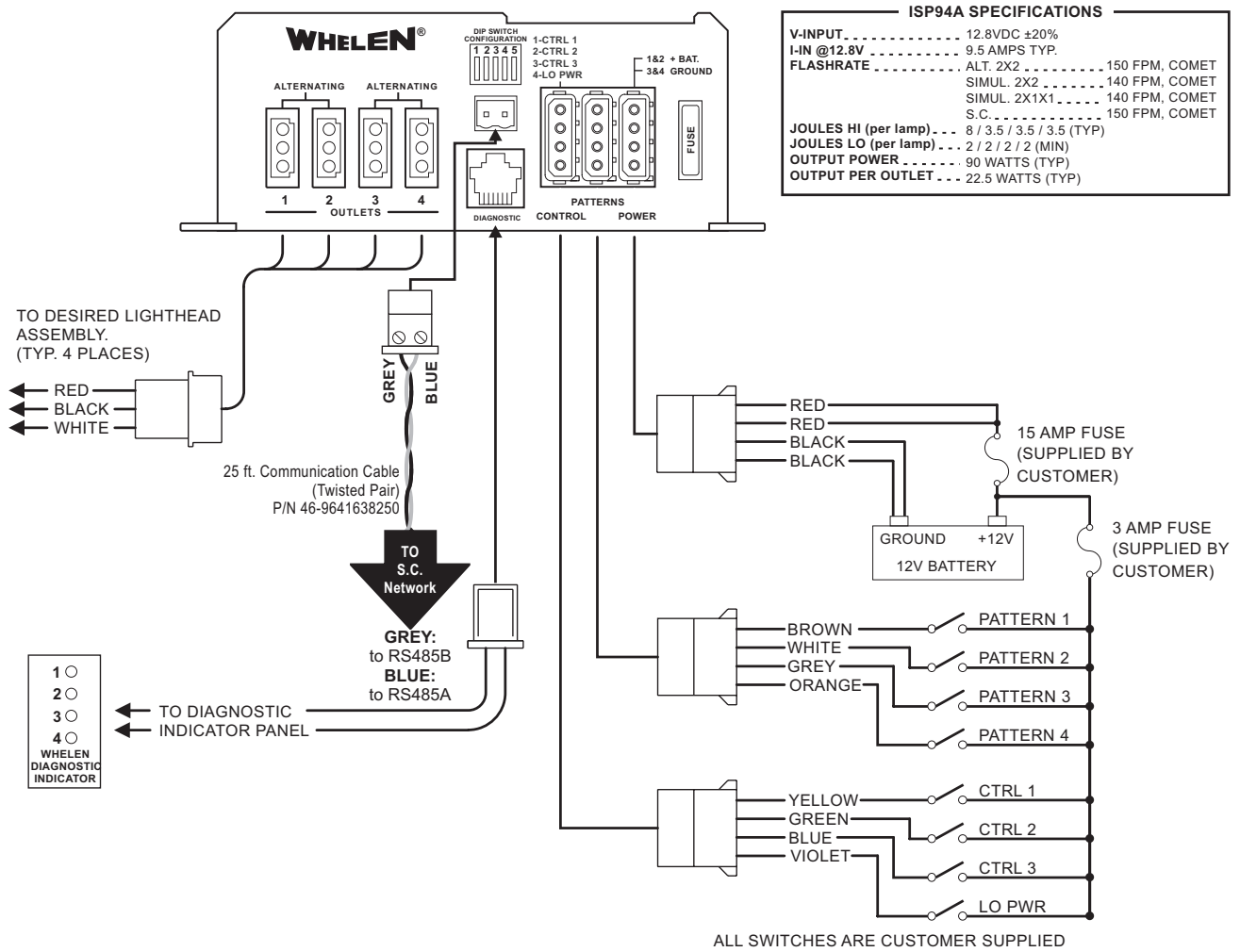

Table 1

FLASH PATTERNS: ■ = +12VDC				
PATTERN WIRE	PATTERN TYPE			
1 2 3 4				
□ □ □ □	CometFlash®*			
■ □ □ □	TripleFlash™			
□ ■ □ □	DoubleFlash			
■ ■ □ □	Rapid Random			
□ □ ■ □	Sequential			
■ □ ■ □	ModuFlash™			
□ ■ ■ □	MicroBurst II™			
■ ■ ■ □	MicroBurst III™			
Pattern Wire 1 = BROWN Pattern Wire 2 = WHITE Pattern Wire 3 = GREY Pattern Wire 4 = ORANGE				

* Only pattern available in Serial Communication mode

Table 2

Hi/Lo Mode Type	Recommended Switch type	To Enable Lo Power Operation	To Restore Hi Power Operation	Dip Switch 3	Dip Switch 4
Latched	Momentary	Apply +12VDC to VIOLET control wire	Turn all strobe outlets off and then on.	OFF	OFF
Level	Single Pole/Single Throw	Apply +12VDC to VIOLET control wire	Remove +12VDC from VIOLET control wire	ON	OFF
Toggle	Momentary	Apply +12VDC to VIOLET control wire	Apply +12VDC to VIOLET control wire	OFF	ON
DISABLED	NONE	No Lo Power Operation In This Mode	Not Applicable	ON	ON

Table 3

If the LED is...	then...
OFF	Either the outlet in question is not enabled, or the power supply is not turned on.
ON continuously	The outlet, strobe cable and strobe light in question are functioning properly.
Flashing rapidly	Either the outlet, strobe cable and/or strobe light in question are malfunctioning. In this condition, further investigation of the components is strongly recommended
ON continuously with a single flash every few seconds	The ISP is operating in Lo power mode.