

WHELEN[®]

ENGINEERING COMPANY INC.

51 Winthrop Road
Chester, Connecticut 06412-0684
Phone: (860) 526-9504
Fax: (860) 525-4078
Internet: www.whelen.com
Sales e-mail: autosale@whelen.com
Canadian Sales e-mail: autocan@whelen.com
Customer Service e-mail: custserv@whelen.com

Installation Guide: MPC-NFPA Multi-Purpose Controller

Automotive: Serial Communication

Safety First

This document provides all the necessary information to allow your Whelen product to be properly and safely installed. Before beginning the installation and/or operation of your new product, the installation technician and operator must read this manual completely. Important information is contained herein that could prevent serious injury or damage.

- **Proper installation of this product requires the installer to have a good understanding of automotive electronics, systems and procedures.**
- **If mounting this product requires drilling holes, the installer MUST be sure that no vehicle components or other vital parts could be damaged by the drilling process. Check both sides of the mounting surface before drilling begins. Also de-burr any holes and remove any metal shards or remnants. Install grommets into all wire passage holes.**
- **If this manual states that this product may be mounted with suction cups, magnets, tape or Velcro®, clean the mounting surface with a 50/50 mix of isopropyl alcohol and water and dry thoroughly.**
- **Do not install this product or route any wires in the deployment area of your air bag. Equipment mounted or located in the air bag deployment area will damage or reduce the effectiveness of the air bag, or become a projectile that could cause serious personal injury or death. Refer to your vehicle owner's manual for the air bag deployment area. The User/Installer assumes full responsibility to determine proper mounting location, based on providing ultimate safety to all passengers inside the vehicle.**
- **For this product to operate at optimum efficiency, a good electrical connection to chassis ground must be made. The recommended procedure requires the product ground wire to be connected directly to the NEGATIVE (-) battery post.**
- **If this product uses a remote device to activate or control this product, make sure that this device is located in an area that allows both the vehicle and the device to be operated safely in any driving condition.**
- **Do not attempt to activate or control this device in a hazardous driving situation.**
- **If this product contains strobe light(s), halogen light(s) or high-intensity LEDs, do not stare directly into these lights. Momentary blindness and/or eye damage could result.**
- **Use only soap and water to clean the outer lens. Use of other chemicals could result in premature lens cracking (crazing) and discoloration. Lenses in this condition have significantly reduced effectiveness and should be replaced immediately. Inspect and operate this product regularly to confirm its proper operation and mounting condition. Do not use a pressure washer to clean this product.**
- **It is recommended that these instructions be stored in a safe place and referred to when performing maintenance and/or reinstallation of this product.**
- **FAILURE TO FOLLOW THESE SAFETY PRECAUTIONS AND INSTRUCTIONS COULD RESULT IN DAMAGE TO THE PRODUCT OR VEHICLE AND/OR SERIOUS INJURY TO YOU AND YOUR PASSENGERS!**

For warranty information regarding this product, visit www.whelen.com/warranty

WARNING!

DISCONNECTING THE VEHICLE BRAKE LAMP CIRCUIT USING ANY SIRENS WITH RELAY OUTPUTS OR SWITCH CONTROLLERS COULD CAUSE VEHICLE OR PROPERTY DAMAGE, SERIOUS INJURY OR EVEN DEATH.

DISABLING THIS CIRCUIT IS A VIOLATION OF THE FEDERAL MOTOR VEHICLE SAFETY STANDARD FOR THE THIRD BRAKE LIGHT, AS WELL AS REAR BRAKE LIGHTS.

FUNCTIONS THAT BLACK OUT THE REAR BRAKE LIGHTS (SOMETIMES CALLED “BRAKE LIGHT CUT OUT”) MAY INTERFERE WITH THE BRAKE SHIFT LOCK MECHANISM, AND CAUSE THE VEHICLE TO MOVE UNEXPECTEDLY AND DANGEROUSLY.

DISCONNECTING THE BRAKE LIGHTS IN ANY WAY IS AT YOUR OWN RISK AND IS NOT RECOMMENDED BY WHELEN.

Installation:

The MPC-NFPA, although technologically advanced, is simple to install. An aftermarket center console is recommended for the mounting location of the MPC-NFPA. This not only allows the driver to reach the MPC-NFPA easily, but also keeps the MPC-NFPA safely out of the path of the vehicle's SRS air-bag. Follow the console manufacturer's instructions for mounting information. The following steps will guide you through the installation process:

Connecting The MPC-NFPA Power Harness...

RED (Power) and BLACK (Ground)

1. Insert the Power Input Harness into its port as shown in Fig. 1. Be sure that the RED wire is located in position 1.
2. Route the RED and BLACK wires toward the firewall. Follow the same path as the factory wire harness.
3. Continue to follow the factory harness through the firewall. To pass the RED and BLACK wires through, it may be necessary to drill a hole in the firewall. If so, be absolutely sure that there are no components that could be damaged by drilling. After the hole is drilled, insert a grommet to protect the wires.
4. Route the RED and BLACK wires along the factory harness towards the battery.
5. Install a 5 Amp fuse block (user supplied) on the end of the RED wire.

Note: Remove the fuse from the fuse block before connecting any wires to the battery!

6. Connect the fuse block wire to the POSITIVE (+) terminal on the battery. There must not be more than two (2) feet of wire between the fuse block and the battery. As the wire between the fuse and the battery is "unprotected", do not allow this wire to come in contact with any other wires!

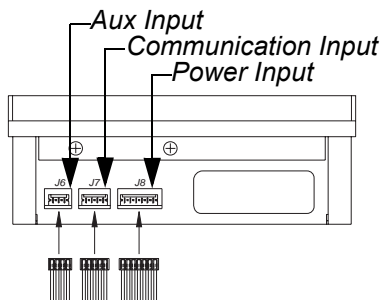

Wire Guide for the MPC-NFPA Communications Ports (by Pin Position, Color Code and Function)

AUX. INPUT		
PIN #	COLOR	FUNCTION
1	BROWN	AUX IN 1
2	RED	AUX IN 2
3	ORANGE	CLEARING
4	YELLOW	BLOCKING

COMMUNICATION INPUT		
PIN #	COLOR	FUNCTION
1	BLUE	+RS485
2	GREY	-RS485
3	WHITE	AUDIO +
4	BLACK	AUDIO -
5	DRAIN	SHIELD

POWER INPUT		
PIN #	COLOR	FUNCTION
1	RED	+12V IN
2	BLACK	GROUND
3	YELLOW	BACK LIGHT
4	VIOLET	HORN RING
5	GREEN	HORN
6	BLUE	RADIO
7	BLUE	RADIO

Fig.1

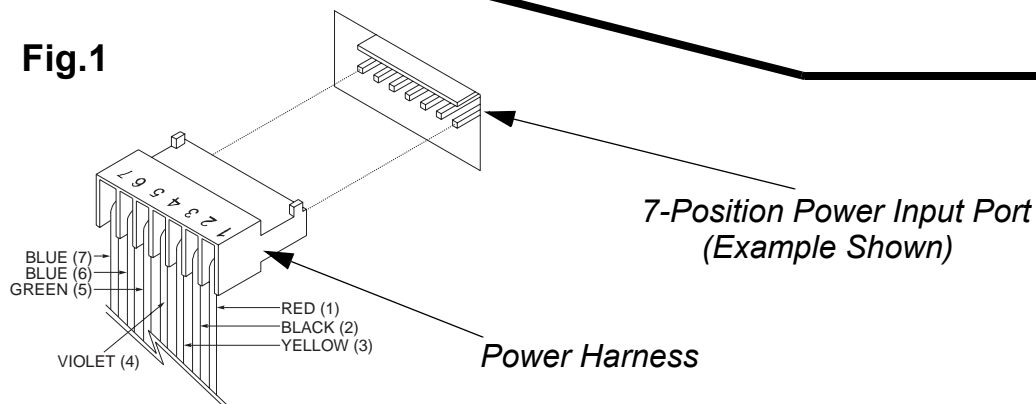

WARNING! ALL CUSTOMER SUPPLIED WIRES THAT CONNECT TO THE POSITIVE (+) TERMINAL OF THE BATTERY MUST BE SIZED TO SUPPLY AT LEAST 125% OF THE MAXIMUM OPERATING CURRENT AND BE FUSED “AT THE BATTERY” TO CARRY THAT LOAD.

7. Connect the BLACK wire to the factory ground, adjacent to the battery.

YELLOW (Back Light Control)

1. Connect the YELLOW wire to a +12VDC source that is activated with the vehicle's ignition switch.

GREEN and VIOLET (Horn Relay)

1. Route the GREEN and VIOLET wires along the factory wire harness and through the firewall at the same point as the RED and BLACK wires.
2. Locate your vehicle's horn relay and route the GREEN and VIOLET wires to this. If possible, follow the factory wire harness to this relay.
3. Cut one of the wires that connect the horn relay to a vehicle horn.
4. Connect the GREEN wire to the wire coming from the horn relay.
5. Connect the VIOLET wire to the wire coming from the horn.

BLUE WIRES (Radio Rebroadcast)

Note: *The two (2) remaining BLUE wires are used to connect your two-way radio's external speaker to the MPC-NFPA for radio rebroadcast. This is an optional connection and does not effect the other operations of the MPC-NFPA.*

Note: *Radio rebroadcast will NOT work with amplified remote speakers! If your remote speaker is amplified (I.E. contains a power amp circuit in the speaker assembly), do not enable the radio rebroadcast feature.*

1. Locate the two wires that connect the external speaker to the two-way radio.
2. Cut one of these wires and splice one of the BLUE wires into this circuit.
3. Cut the remaining speaker wire and splice the remaining BLUE wire into this circuit.

Connecting the MPC-NFPA Communication Cable...

1. Insert the Communication Input Cable into its port as shown in Fig. 1. Be sure that the BLUE wire is located in position 1.
2. Route the Communication Cable towards the BL627 Siren Amplifier.
3. Strip approximately 1/4" of insulation off the ends of each wire.
4. Insert the wires into the Phoenix™ connector located on the back of the BL627 as shown in the wiring diagram (pg. 5).
5. Tighten the screws on the Phoenix connector (with a small, flat blade screwdriver) to secure the wires to the BL627.

Connecting the MPC-NFPA Auxiliary Input Cable...

Note: *The MPC-NFPA Auxiliary Input Cable is made up of four (4) color coded wires and provides two (2) auxiliary inputs.*

1. Insert the Communication Input Cable into its port as shown in Fig. 1.
2. The wires are coded as follows:

<u>WIRE</u>	<u>FUNCTION</u>
BROWN	AUX.INPUT #1 (+12VDC Input Switch)
RED	AUX.INPUT #2 (+12VDC Input Switch)
ORANGE	Clearing the Right of Way - Activates the Designated Warning Light System
YELLOW	Blocking the Right of Way - Activates the Designated Warning Light System

(See Fig. 2 for better illustration of the use of the Auxiliary Input Cable)

When all of the necessary connections outlined in this manual have been completed and checked, the 5 Amp fuse can now be installed into the fuse block between the MPC-NFPA and the battery.

Fig.2

