

ROUTE 145, WINTHROP ROAD
CHESTER, CONNECTICUT 06412-0684
TELEPHONE: (860) 526-9504
FAX: (860) 526-4078

RB-6 / HID-to-Halogen Conversion

Removal and Installation . . .

- After removing the optic dome to get to the inside of your beacon, (see beacon instruction sheet) remove the old lamp base by removing the three screws and unplugging it from the BLACK and WHITE wires.
NOTE: You will not need the old lamp base and wires but save the three screws to use on the new base.
- Cut the BLACK and WHITE wires that connect to the H.I.D. ballast. (Fig. 1) Be sure to cut them close to the ballast as shown. Clip and remove the tywrap holding them to the RED and BLACK wires then remove them by pulling them out through the slot and out the center.
- Cut the BLACK and RED wires coming from the pre-conditioner. Be sure to cut them on the "motor side" of the support they run through, as close to the support as possible. (Fig. 2) (strip ends approx. 1/4")
NOTE: Also clip the excess BLACK, WHITE and YELLOW wires still attached to the pre-conditioner and discard them.
- Take the new lamp socket and run the wires down through the middle of the base and out the slot in the side. (Fig. 3)
- Now attach the socket base to the base of the beacon using the 3 screws from the old lamp base.
- Crimp the wires from the new lamp (With the butt terminals supplied) to the RED and BLACK wires and run them behind the motor so they'll be out of the way. (BLACK to BLACK / RED to WHITE) (Fig. 3) Be sure

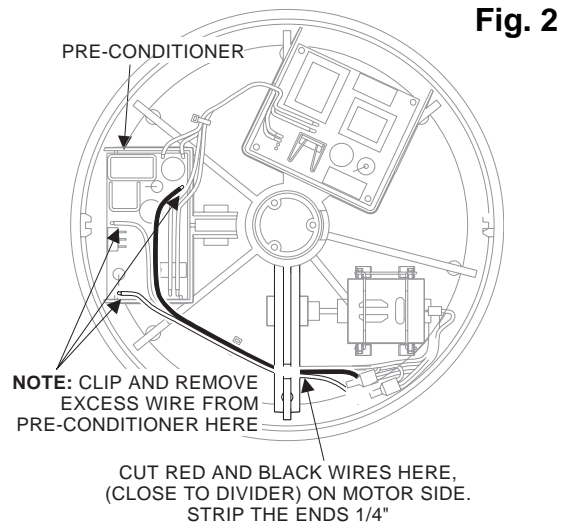

to trim all excess wire so you only leave what you need. Too much extra wire may rub against moving parts.

- Reassemble the beacon and test it.

The outer surfaces of this product may be cleaned with mild soap and water. Use of any other chemicals may void product warranty. Do not use a pressure washer.

Part Numbers

Halogen Lampholder.....	33-0042444-00
35 Watt Halogen Lamp	34-0041987-02
50 Watt Halogen Lamp	34-0041987-06

WARNING: DO NOT INSTALL BULBS EXCEEDING 50 WATTS.

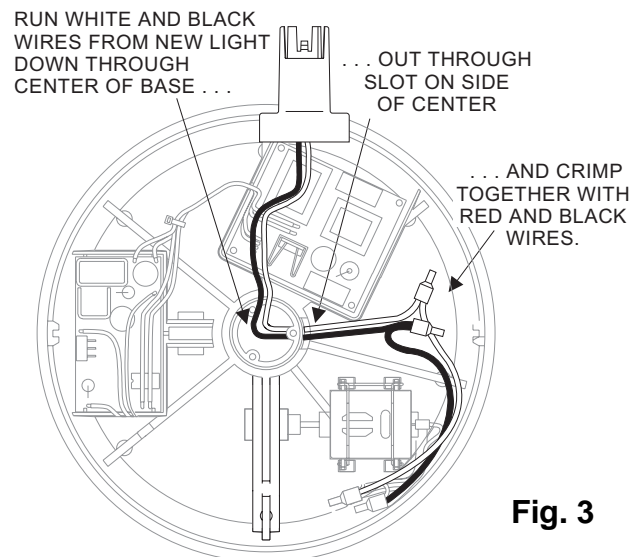
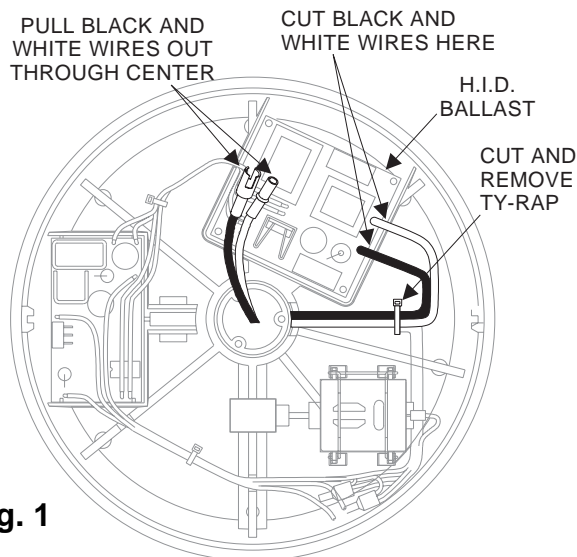

ADVANTEDGE LIGHTBAR / HID-to-Halogen Conversion

Advantage . . . It is always best to do one side of the bar at a time so you will have the other side to refer to if needed.

Removal of Old Lamp . . .

1. Remove the 6 screws holding on the endcap and remove the endcap.
2. Remove the set screw holding on the alley bracket, slide the alley bracket out and set aside. (Fig. 1)
3. Slide the side lenses out so you can access the motor/bulb assembly.
4. Unplug the lamp and motor from the power harness and slide the rotator base assembly out of the bar. (Fig. 2)
5. With the base out of the bar remove the reflector assembly screws and pull off the reflector. (Fig. 2)
6. Remove and discard the HID assembly. (Be sure to save the 3 screws securing it, to use with the new lamp.) (Fig. 2)

Installation of New Lamp . . .

1. Run the BLACK and WHITE wires of the new lamp down the center of the base, out through the slot on the side and attach new halogen assembly using the 3 screws from your old HID assembly.
2. Cut the spade connectors off the RED and BLACK motor wires.
3. Twist the lamp wires together with the motor wires and crimp with the supplied spade connectors. (Lamp BLACK (-) to Motor RED and Lamp WHITE (+) to Motor BLACK.) See figure 3.

WARNING: DO NOT INSTALL BULBS EXCEEDING 35 WATTS.

NOTE: Be sure to cut all wires close to the Pre-Conditioner / HID Ballast. (Fig. 4)

