

# WHELEN<sup>®</sup>

ENGINEERING COMPANY INC.

51 Winthrop Road  
Chester, Connecticut 06412-0684  
Phone: (860) 526-9504  
Fax: (860) 526-4078  
Internet: [www.whelen.com](http://www.whelen.com)  
Sales e-mail: [autosale@whelen.com](mailto:autosale@whelen.com)  
Canadian Sales e-mail: [autocan@whelen.com](mailto:autocan@whelen.com)  
Customer Service e-mail: [custserv@whelen.com](mailto:custserv@whelen.com)

## Installation Guide: Model CR212 Responder<sup>®</sup> Cadet<sup>™</sup>

### Safety First

This document provides all the necessary information to allow your Whelen product to be properly and safely installed. Before beginning the installation and/or operation of your new product, the installation technician and operator must read this manual completely. Important information is contained herein that could prevent serious injury or damage.

- **Proper installation of this product requires the installer to have a good understanding of automotive electronics, systems and procedures.**
- **If mounting this product requires drilling holes, the installer MUST be sure that no vehicle components or other vital parts could be damaged by the drilling process. Check both sides of the mounting surface before drilling begins. Also de-burr the holes and remove any metal shards or remnants. Install grommets into all wire passage holes.**
- **If this manual states that this product may be mounted with suction cups, magnets, tape or Velcro<sup>®</sup>, clean the mounting surface with a 50/50 mix of isopropyl alcohol and water and dry thoroughly.**
- **Do not install this product or route any wires in the deployment area of your air bag. Equipment mounted or located in the air bag deployment area will damage or reduce the effectiveness of the air bag, or become a projectile that could cause serious personal injury or death. Refer to your vehicle owner's manual for the air bag deployment area. The User/Installer assumes full responsibility to determine proper mounting location, based on providing ultimate safety to all passengers inside the vehicle.**
- **For this product to operate at optimum efficiency, a good electrical connection to chassis ground must be made. The recommended procedure requires the product ground wire to be connected directly to the NEGATIVE (-) battery post (this does not include products that use cigar power cords).**
- **If this product uses a remote device for activation or control, make sure that this device is located in an area that allows both the vehicle and the device to be operated safely in any driving condition.**
- **Do not attempt to activate or control this device in a hazardous driving situation.**
- **This product contains either strobe light(s), halogen light(s), high-intensity LEDs or a combination of these lights. Do not stare directly into these lights. Momentary blindness and/or eye damage could result.**
- **Use only soap and water to clean the outer lens. Use of other chemicals could result in premature lens cracking (crazing) and discoloration. Lenses in this condition have significantly reduced effectiveness and should be replaced immediately. Inspect and operate this product regularly to confirm its proper operation and mounting condition. Do not use a pressure washer to clean this product.**
- **It is recommended that these instructions be stored in a safe place and referred to when performing maintenance and/or reinstallation of this product.**
- **FAILURE TO FOLLOW THESE SAFETY PRECAUTIONS AND INSTRUCTIONS COULD RESULT IN DAMAGE TO THE PRODUCT OR VEHICLE AND/OR SERIOUS INJURY TO YOU AND YOUR PASSENGERS!**

**For warranty information regarding this product, visit [www.whelen.com/warranty](http://www.whelen.com/warranty)**

The Responder® Cadet™ Series, utilizes a base design that enables a dash/deck, magnetic (optional), or permanent mounting. The Responder Cadet features a relampable halogen bulb that has been designed to allow easy replacement.

**FEATURES:**

- 50 Watt Equivalent Halogen Bulb.
- 2 amps @ 13.6 VDC.
- Optional Base Mounted push button On/Off switch.
- Optional Coil Cord
- Removable Plastic Shield for rear flash cutoff.

**IMPORTANT WARNING:** As mounting the Responder Cadet will require drilling, it is absolutely necessary to make sure that no other vehicle components could be damaged in the process. Check both sides of the mounting surface before starting and if damage is possible, select a different mounting location.

**Installation: PERMANENT MOUNT**

1. Check to make sure that no vehicle components will interfere with the selected mounting location of this unit.
2. Position the Cadet on the proposed mounting location. Using an awl or other suitable tool, and using the mounting holes as a guide (See Fig. 1), poke a hole through the base pad and scribe the mounting surface where the mounting holes are to be drilled.
3. Carefully drill the mounting holes in the areas scribed in step 2. The diameter of these holes will be determined by the size of the mounting hardware (#6 x 1") and the thickness of the mounting surface.

4. Using the supplied #6 x 1" phillips pan head sheet metal screws, secure the Cadet to the mounting surface.

**Installation: TAMPER RESISTANT PERMANENT MOUNT**

1. Check to make sure that no vehicle components will interfere with the selected mounting location of this unit.
2. Remove the lens from the base of the unit by positioning a flat head screw driver or other suitable tool in the opening between the lens and the base and lifting the tool in an upward motion (See Fig. 1).
3. Locate the mounting holes inside the base of the Cadet (See Fig. 2). Carefully drill out the mounting holes through the base and base pad of the unit. The diameter of these holes should be sized to a #6 sheet metal screw.
4. Position the Cadet on the proposed mounting location. Using an awl or other suitable tool, scribe the mounting surface where the mounting holes are to be drilled and scribe the area the wires are to pass through (Fig. 2).
5. Carefully drill the mounting holes along with the wire hole in the areas scribed in step 4. The diameter of these holes will be determined by the size of the mounting hardware (#6 x 1") and the thickness of the mounting surface.
6. Using the supplied #6 x 1" phillips pan head sheet metal screws, secure the Cadet to the mounting location.

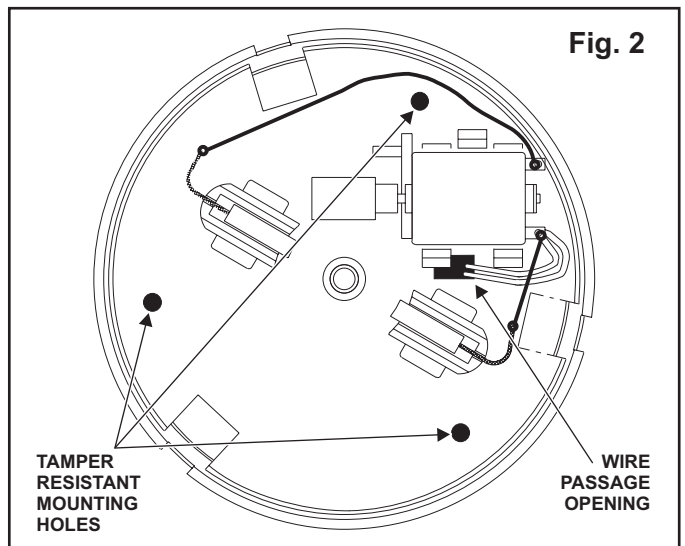
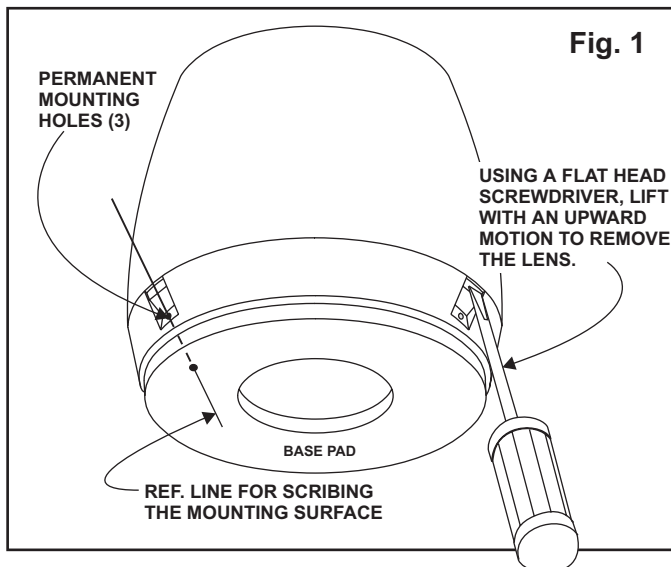

**Wiring To Power:**

1. Extend the RED and BLACK wires to the battery.

**WARNING: All customer supplied wires that connect to the positive terminal of the battery, must be sized to supply at least 125% of the maximum operating current and fused "at the battery" to carry that load.**

2. Connect the BLACK wire directly to the vehicle's chassis ground (typically adjacent to the battery).
3. Connect the RED wire to one end of the user supplied fuse block (3 amps). After the fuse block is in place, connect the RED wire to the POSITIVE(+) terminal of the battery.

After this connection has been made, inspect the circuit wires and make sure they are wired correctly. Replace the fuse if blown with one of an identical amp. rating as the original. If the fuse blows after installation or activation, contact Whelen Engineering Technical Support.

**Removing The Halogen Bulb:**

1. Remove dome lens as shown in Fig. 1.
2. Locate the RED and BLACK wire connections on the back side of the reflector. Disconnect the two wires by pulling back on the wire clips shown in Fig. 3, View #1.
3. Bend the two lamp leads protruding from the reflector so that they are straight, and remove the bulb.
4. When installing the new halogen bulb, follow these steps above in the reversed order.

**CAUTION:** Replacing any halogen bulb requires the use of safety glasses to prevent injury. Do not handle the bulb with bare hands. Use gloves to prevent possible injury.

**WARNING!** The use of any Whelen magnetically mounted warning light on a vehicle while it is in motion is at the sole discretion and risk of the user and is not recommended.

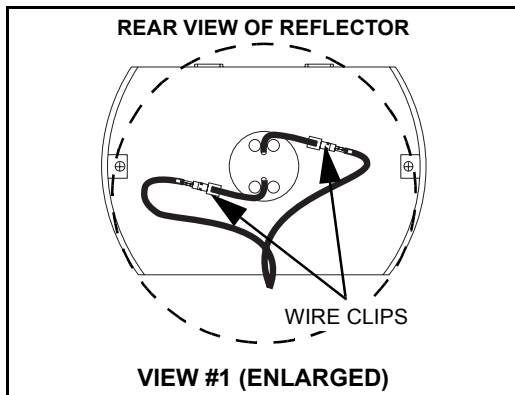

The outer surfaces of this product may be cleaned with mild soap and water. Use of any other chemicals may void the product warranty. Do not use a pressure washer.

