

WHELEN[®]

ENGINEERING COMPANY INC.

Route 145, Winthrop Road,
Chester, Connecticut 06412

Phone: (860) 526-9504

Fax: (860) 526-4078

Internet: www.whelen.com

Sales e-mail: autosale@whelen.com

Canadian Sales e-mail: autocan@whelen.com

Customer Service e-mail: custserv@whelen.com

Installation Guide: UHF-2150 Headlight High Beam Flasher

Safety First

This document provides all the necessary information to allow your Whelen product to be properly and safely installed. Before beginning the installation and/or operation of your new product, the installation technician and operator must read this manual completely. Important information is contained herein that could prevent serious injury or damage.

- **Proper installation of this product requires the installer to have a good understanding of automotive electronics, systems and procedures.**
- **If mounting this product requires drilling holes, the installer MUST be sure that no vehicle components or other vital parts could be damaged by the drilling process. Check both sides of the mounting surface before drilling begins. Also de-burr any holes and remove any metal shards or remnants. Install grommets into all wire passage holes.**
- **If this product is mounted with tape or Velcro™, clean the mounting surface with a 50/50 mix of isopropyl alcohol and water and dry thoroughly.**
- **Do not install this product or route any wires in the deployment area of your air bag. Equipment mounted or located in the air bag deployment area will damage or reduce the effectiveness of the air bag, or become a projectile that could cause serious personal injury or death. Refer to your vehicle owners manual for the air bag deployment area. The User/Installer assumes full responsibility to determine proper mounting location, based on providing ultimate safety to all passengers inside the vehicle.**
- **For this product to operate at optimum efficiency, a good electrical connection to chassis ground must be made. The recommended procedure requires the product ground wire to be connected directly to the NEGATIVE (-) battery post.**
- **If this product uses a remote device to activate or control this product, make sure that this control is located in an area that allows both the vehicle and the control to be operated safely in any driving condition.**
- **Do not attempt to activate or control this device in a hazardous driving situation.**
- **It is recommended that these instructions be stored in a safe place and referred to when performing maintenance and/or reinstallation of this product.**
- **FAILURE TO FOLLOW THESE SAFETY PRECAUTIONS AND INSTRUCTIONS COULD RESULT IN DAMAGE TO THE PRODUCT OR VEHICLE AND/OR SERIOUS INJURY TO YOU AND YOUR PASSENGERS!**

The Whelen UHF2150 Headlight Flasher will alternately flash the high beam headlights on any vehicle with a 12 volt D.C. negative (-) ground electrical system. When installed properly, the UHF2150 will allow standard use of the vehicular headlight system during nighttime operation.

Installation:

IMPORTANT! It is the responsibility of the installer to make sure that the high beam and low beam filaments of a dual filament bulb never come on together. The excessive heat generated by this condition will melt the headlight assembly. The brown disable wire may have to be connected to the parking lights or the low beams to override the flasher and prevent both filaments from coming on simultaneously.

Caution: Disconnect the battery from the electrical system before attempting any part of this installation!

Note: The use of a flashing headlight system may be regulated by state, county, or municipal authorities. It is the responsibility of the end user to comply with these regulations.

Note: The installation of a headlight flasher system requires a modification to the standard headlight wiring harness. This modification may effect the warranty of your vehicle. It is the responsibility of the end user to verify the warranty conditions with the vehicle manufacturer. Also, the use of a headlight flasher may shorten the high beam bulb life.

Note: Before attempting the installation of the UHF2150 headlight flasher, thoroughly read and understand instructions and steps shown below!

WARNING! Disconnect the battery from the electrical system before attempting any part of this installation!

1. Mount the UHF2150 in the engine compartment near the battery and headlights. DO NOT mount the unit directly on the engine or close to exhaust system.
2. Locate the wire that connects the high beam headlights and cut it (see wiring diagrams on page 2).
3. **Black Wire, Ground (-)** To be connected to a good chassis ground. This black wire may be extended with an 18 AWG wire.
4. **Brown Wire, Nighttime cut-off feature.** Connect this wire to the parking light or low beam circuit to disable the flasher when headlights are on. This is to prevent both filament in a

dual filament bulb from being on simultaneously (or if required in your jurisdiction).

5. **Blue Wire, Output #1.** Connect the blue wire to the end of the cut wire from the driver side high beam headlight (step 2). This blue wire may be extended with 14 AWG wire.
6. **Yellow Wire, Output #2.** Connect the yellow wire to the end of the cut wire from the passenger side high beam headlight (see step 2). This yellow wire may be extended with a 14 AWG wire.
7. **Orange Wire, Flasher On/Off Control.** Connect the orange wire to a customer supplied ON/OFF switch rated for at least 200ma. The switch must be connected to positive (+) 12 volt D.C.. This orange wire may be extended with an 18 AWG wire.
8. **Red Wire, Power Source.** Connect the red wire to a high current positive (+) 12 volt D.C. power source. Fuse this wire with a customer supplied 15 amp fuse as close as possible to the power source. This red wire may be extended with a 14 AWG wire.

WARNING! All customer supplied wires that connect to the positive terminal of the battery must be sized to supply at least 125% of the maximum operating current and FUSED at the battery to carry the load. DO NOT USE CIRCUIT BREAKERS WITH THIS PRODUCT!

9. **Make sure the control switch is in the off position.** Check all wiring for good connections. Reconnect the vehicle's battery to the electrical system.

Operation:

Daylight: (vehicle's headlight switch off). Turn the headlight flasher control switch to the ON position. The high beam headlights will alternately flash for a total of 210 flashes per minute.

Nighttime: (Nighttime cutout feature not used, see step 4). With the vehicle's headlight switch in the parking light position or low beam position, and the headlight flasher control switch in the ON position, the high beam headlights will alternately flash for a total of 210 flashes per minute, while the parking lights or the low headlight beams operate normally. If the high beam control switch (dimmer switch) is activated, the high beam headlights will steady burn. When the high beam control switch (dimmer switch) is restored to low beam operation, the high beam headlights will resume flashing.

NIGHTTIME: (Nighttime cut-out feature used, see step 4). When the nighttime cutout feature is used, the UHF2150 Headlight Flasher is nonoperational any time the vehicle's headlight switch (dimmer switch) is used in either the parking light position or the headlight position.

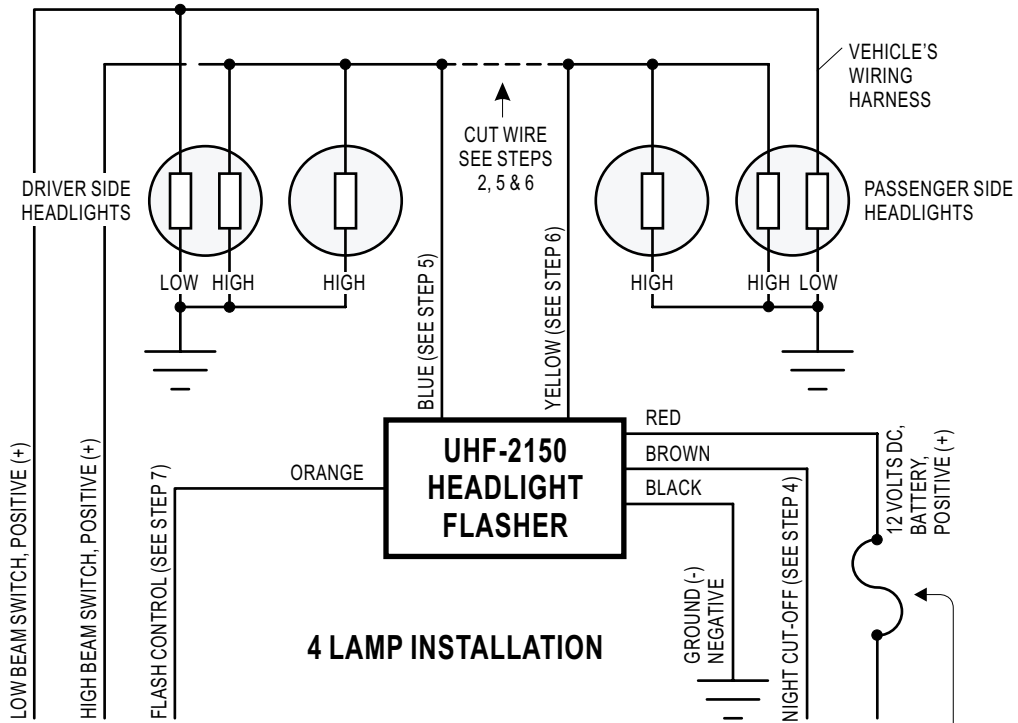

CUSTOMER SUPPLIED 15 AMP FUSE TO BE LOCATED AS CLOSE TO POWER SOURCE AS POSSIBLE (SEE STEP 8)

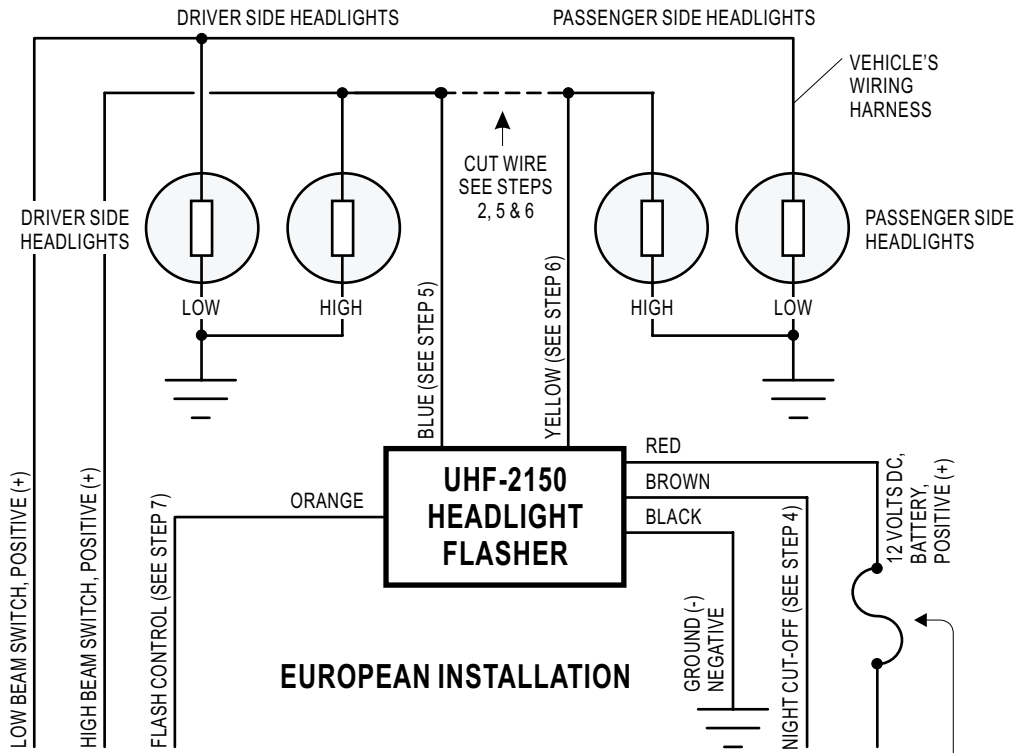

CUSTOMER SUPPLIED 15 AMP FUSE TO BE LOCATED AS CLOSE TO POWER SOURCE AS POSSIBLE (SEE STEP 8)