

# WHELEN<sup>®</sup>

ENGINEERING COMPANY INC.

Route 145, Winthrop Road,  
Chester, Connecticut 06412  
Phone: (860) 526-9504  
Fax: (860) 526-4078  
Internet: [www.whelen.com](http://www.whelen.com)  
Sales e-mail: [autosale@whelen.com](mailto:autosale@whelen.com)  
Canadian Sales e-mail: [autocan@whelen.com](mailto:autocan@whelen.com)  
Customer Service e-mail: [custserv@whelen.com](mailto:custserv@whelen.com)

**Installation Guide:**  
**SA122DB (Aluminum)**  
**SP123DB (Plastic)**  
**Siren Speaker**  
**1998 Ford Crown Victoria**  
**Bracket Model BKGCV98**

Automotive: Sirens/Switches

## Safety First

This document provides all the necessary information to allow your Whelen product to be properly and safely installed. Before beginning the installation and/or operation of your new product, the installation technician and operator must read this manual completely. Important information is contained herein that could prevent serious injury or damage.

- **Proper installation of this product requires the installer to have a good understanding of automotive electronics, systems and procedures.**
- **If mounting this product requires drilling holes, the installer MUST be sure that no vehicle components or other vital parts could be damaged by the drilling process. Check both sides of the mounting surface before drilling begins. Also de-burr any holes and remove any metal shards or remnants. Install grommets into all wire passage holes.**
- **If this manual states that this product may be mounted with tape or Velcro™, clean the mounting surface with a 50/50 mix of isopropyl alcohol and water and dry thoroughly.**
- **Do not install this product or route any wires in the deployment area of your air bag. Equipment mounted or located in the air bag deployment area will damage or reduce the effectiveness of the air bag, or become a projectile that could cause serious personal injury or death. Refer to your vehicle owners manual for the air bag deployment area. The User/Installer assumes full responsibility to determine proper mounting location, based on providing ultimate safety to all passengers inside the vehicle.**
- **For this product to operate at optimum efficiency, a good electrical connection to chassis ground must be made. The recommended procedure requires the product ground wire to be connected directly to the NEGATIVE (-) battery post.**
- **If this product uses a remote device to activate or control this product, make sure that this control is located in an area that allows both the vehicle and the control to be operated safely in any driving condition.**
- **Do not attempt to activate or control this device in a hazardous driving situation.**
- **It is recommended that these instructions be stored in a safe place and referred to when performing maintenance and/or reinstallation of this product.**
- **FAILURE TO FOLLOW THESE SAFETY PRECAUTIONS AND INSTRUCTIONS COULD RESULT IN DAMAGE TO THE PRODUCT OR VEHICLE AND/OR SERIOUS INJURY TO YOU AND YOUR PASSENGERS!**

## Mounting...

1. Open the hood and locate the black plastic panel that covers the area between the top of the grill and the radiator support. Release the 3, twist-lok screws that secure this panel in place and remove the panel from the vehicle.
2. Remove the grill from the vehicle.
3. Position the mounting bracket onto the passenger side of the radiator support adjacent to the hood latch. Using the bracket as a template, drill through both the upper and lower planes of the radiator support with a 3/8" drill bit (see Fig. 1).
4. Remove the bracket from the vehicle. Install the two Tinnerman Nuts onto the bracket in the area shown in Fig. 1. Mount the speaker box to the mounting bracket as shown, using the hardware supplied with the siren box.
5. Return the Siren/Bracket assembly to its mounting location, via the open grill area. **Note:** When mounting the bracket to the vehicle, do not allow the speaker wires to be positioned between the bracket and the radiator support.
6. Position the two nylon spacers onto the bracket as shown in Fig. 1.
7. Using the hardware included with the mounting bracket, mount the bracket/siren box securely to the vehicle.
8. Extend the WHITE (Positive) and BLACK (Negative) speaker wires to your siren amplifier and connect as outlined in the siren amplifier's instruction sheet.
9. Return all components to their original location.

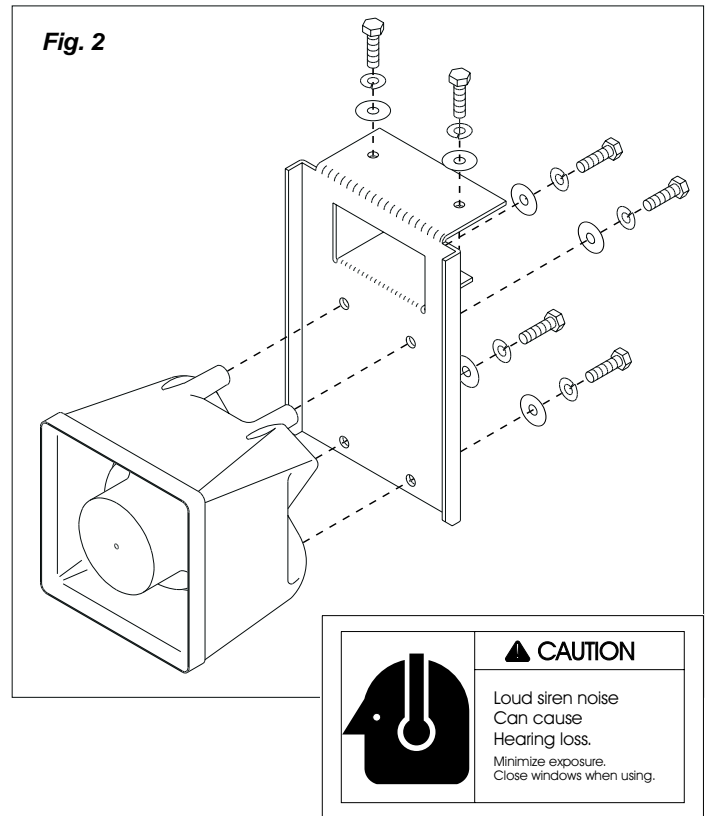
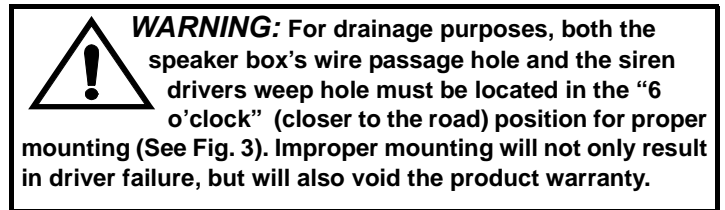

Fig. 1

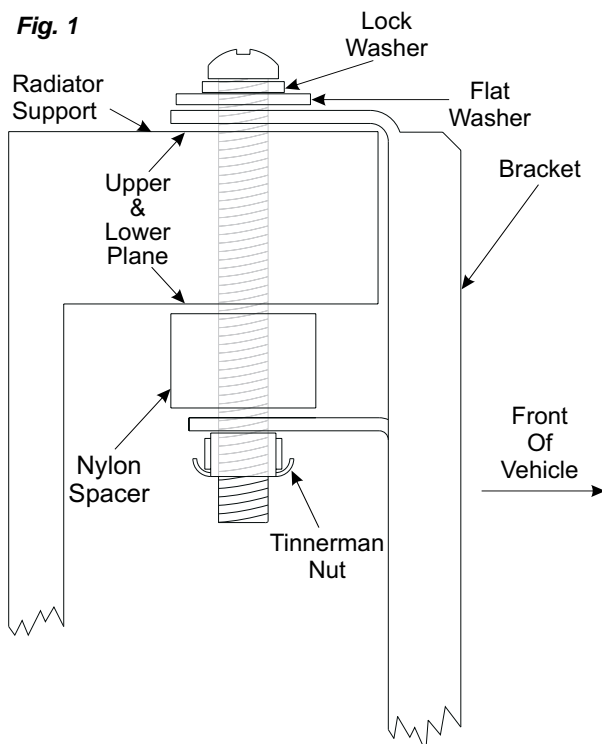
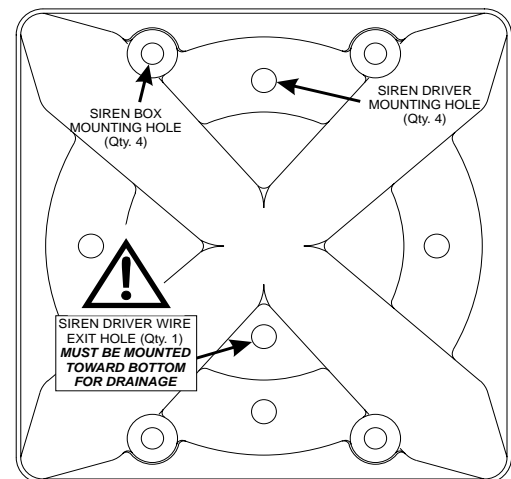

Fig. 3



### Parts List for Kit BKGCV98

Qty	Description	Part Number
1	Siren Mounting Bracket	07-262798-000
2	Tinnerman Nuts	13-046621-100
2	Nylon Spacers	20-243229600
2	5/16" - 18 x 3" Phillips Round Head Machine Screw	
2	5/16" SS Split Lockwasher	
2	5/16" SS Flat Washer	