

WHELEN[®]

ENGINEERING COMPANY INC.

51 Winthrop Road
Chester, Connecticut 06412-0684
Phone: (860) 526-9504
Fax: (860) 526-4078
Internet: www.whelen.com
Sales e-mail: autosale@whelen.com
Canadian Sales e-mail: canadiansales@whelen.com
Customer Service e-mail: custserv@whelen.com

Installation Guide:
Mirror-Beam Model MBEX98
1998 Ford Explorer

Warnings to Installers

Whelen's emergency vehicle warning devices must be properly mounted and wired in order to be effective and safe. Read and follow all of Whelen's written instructions when installing or using this device. Emergency vehicles are often operated under high speed stressful conditions which must be accounted for when installing all emergency warning devices. Controls should be placed within convenient reach of the operator so that they can operate the system without taking their eyes off the roadway. Emergency warning devices can require high electrical voltages and/or currents. Properly protect and use caution around live electrical connections. Grounding or shorting of electrical connections can cause high current arcing, which can cause personal injury and/or vehicle damage, including fire. Many electronic devices used in emergency vehicles can create or be affected by electromagnetic interference. Therefore, after installation of any electronic device it is necessary to test all electronic equipment simultaneously to insure that they operate free of interference from other components within the vehicle. Never power emergency warning equipment from the same circuit or share the same grounding circuit with radio communication equipment. All devices should be mounted in accordance with the manufacturer's instructions and securely fastened to vehicle elements of sufficient strength to withstand the forces applied to the device. Driver and/or passenger air bags (SRS) will affect the way equipment should be mounted. This device should be mounted by permanent installation and within the zones specified by the vehicle manufacturer, if any. Any device mounted in the deployment area of an air bag will damage or reduce the effectiveness of the air bag and may damage or dislodge the device. Installer must be sure that this device, its mounting hardware and electrical supply wiring does not interfere with the air bag or the SRS wiring or sensors. Mounting the unit inside the vehicle by a method other than permanent installation is not recommended as unit may become dislodged during swerving; sudden braking or collision. Failure to follow instructions can result in personal injury. Whelen assumes no liability for any loss resulting from the use of this warning device. **PROPER INSTALLATION COMBINED WITH OPERATOR TRAINING IN THE PROPER USE OF EMERGENCY WARNING DEVICES IS ESSENTIAL TO INSURE THE SAFETY OF EMERGENCY PERSONNEL AND THE PUBLIC.**

Warnings to Users

Whelen's emergency vehicle warning devices are intended to alert other operators and pedestrians to the presence and operation of emergency vehicles and personnel. However, the use of this or any other Whelen emergency warning device does not guarantee that you will have the right-of-way or that other drivers and pedestrians will properly heed an emergency warning signal. Never assume you have the right-of-way. It is your responsibility to proceed safely before entering an intersection, driving against traffic, responding at a high rate of speed, or walking on or around traffic lanes. Emergency vehicle warning devices should be tested on a daily basis to ensure that they operate properly. When in actual use, the operator must ensure that both visual and audible warnings are not blocked by vehicle components (i.e.: open trunks or compartment doors), people, vehicles, or other obstructions. It is the user's responsibility to understand and obey all laws regarding emergency warning devices. The user should be familiar with all applicable laws and regulations prior to the use of any emergency vehicle warning device. Whelen's audible warning devices are designed to project sound in a forward direction away from the vehicle occupants. However, because sustained periodic exposure to loud sounds can cause hearing loss, all audible warning devices should be installed and operated in accordance with the standards established by the National Fire Protection Association.

Safety First

This document provides all the necessary information to allow your Whelen product to be properly and safely installed. Before beginning the installation and/or operation of your new product, the installation technician and operator must read this manual completely. Important information is contained herein that could prevent serious injury or damage.

- **Proper installation of this product requires the installer to have a good understanding of automotive electronics, systems and procedures.**
- **Whelen Engineering requires the use of waterproof butt splices and/or connectors if that connector could be exposed to moisture.**
- **Any holes, either created or utilized by this product, should be made both air- and watertight using a sealant recommended by your vehicle manufacturer.**
- **Failure to use specified installation parts and/or hardware will void the product warranty.**
- **If mounting this product requires drilling holes, the installer MUST be sure that no vehicle components or other vital parts could be damaged by the drilling process. Check both sides of the mounting surface before drilling begins. Also de-burr the holes and remove any metal shards or remnants. Install grommets into all wire passage holes.**
- **If this manual states that this product may be mounted with suction cups, magnets, tape or Velcro®, clean the mounting surface with a 50/50 mix of isopropyl alcohol and water and dry thoroughly.**
- **Do not install this product or route any wires in the deployment area of your air bag. Equipment mounted or located in the air bag deployment area will damage or reduce the effectiveness of the air bag, or become a projectile that could cause serious personal injury or death. Refer to your vehicle owner's manual for the air bag deployment area. The User/Installer assumes full responsibility to determine proper mounting location, based on providing ultimate safety to all passengers inside the vehicle.**
- **For this product to operate at optimum efficiency, a good electrical connection to chassis ground must be made. The recommended procedure requires the product ground wire to be connected directly to the NEGATIVE (-) battery post (this does not include products that use cigar power cords).**
- **If this product uses a remote device for activation or control, make sure that this device is located in an area that allows both the vehicle and the device to be operated safely in any driving condition.**
- **Do not attempt to activate or control this device in a hazardous driving situation.**
- **This product contains either strobe light(s), halogen light(s), high-intensity LEDs or a combination of these lights. Do not stare directly into these lights. Momentary blindness and/or eye damage could result.**
- **Use only soap and water to clean the outer lens. Use of other chemicals could result in premature lens cracking (crazing) and discoloration. Lenses in this condition have significantly reduced effectiveness and should be replaced immediately. Inspect and operate this product regularly to confirm its proper operation and mounting condition. Do not use a pressure washer to clean this product.**
- **It is recommended that these instructions be stored in a safe place and referred to when performing maintenance and/or reinstallation of this product.**
- **FAILURE TO FOLLOW THESE SAFETY PRECAUTIONS AND INSTRUCTIONS COULD RESULT IN DAMAGE TO THE PRODUCT OR VEHICLE AND/OR SERIOUS INJURY TO YOU AND YOUR PASSENGERS!**

To Remove the Side Mirror Assembly:

1. Remove the door panel from the vehicle.
2. Remove the nuts that secure the mirror housing to the vehicle. Unplug the mirror's harness cable from the door's power harness.
3. Carefully remove the mirror housing from the vehicle.

To Prepare the Mirror Assembly:

1. Position the mirror assembly on the workbench so the mirror surface is facing away from the installer.
2. Locate the area marked "Corner". From this point, measure a distance of 0.5" along the ascending vertical line (Fig. 1).
3. From this point, measure a distance of 3.5" parallel with line "A".
4. After measuring the distances indicated, mark this location.
5. Using a 3/8" drill bit, carefully drill into the marked area. Be sure to remove any shavings caused by the drilling process.
6. Now position the mirror assembly so that its mounting surface is facing the installer. Locate the rubber extrusion projecting from the rubber mounting gasket. Cut an opening through the outer-most surface so that the harness cable can pass through (See Fig. 2).

To Prepare the Strobe Harness:

NOTE: Because the strobe harness must be routed through a specific, narrow and twisting path within the mirror assembly, it is necessary to temporarily extend the length of the harness with a make-shift "snake".

1. Locate the tie-wrap included with your mirror beam and cut the fastener-end off.
2. Locate the end of the strobe harness that has SOCKET-type terminals installed on the free wires. Cut off the non-insulated wire (it is not used in this application).
3. Strongly secure the tie-wrap to the strobe harness with electrical or similar tape. Although the purpose of this procedure is to extend the harness length as much as possible using the tie-wrap, it is important to have a sufficient length of the tie-wrap secured to the harness (2" minimum).

Routing the Strobe Cable:

1. Insert the tie-wrap through the opening made in step 6 of the "To prepare the mirror assembly" section. **Do not attempt to remove either the rubber or foam rubber gaskets that are present.**
2. Route the cable through the opening shown in Figure 3. Feed the cable through this opening until the tie-wrap begins to exit the assembly from behind the mirror. Continue to feed the cable through until approximately 18" of cable has exited the assembly.
3. Now route the tie-wrap back into the mirror assembly and out of the hole drilled in step 5 of the "To prepare the mirror assembly" section (Fig. 4). There should not be more than 4 or 5 inches of harness sticking out of the hole. If the length is different from this, adjust harness length accordingly.
4. The wire terminals are now inserted into their 3 position connector (supplied) as follows (For detailed information, refer to the instruction tag attached to the harness):

Position 1 = Red Position 2 = Black Position 3 = White

Affixing the MirrorBeam to the Mirror Housing:

NOTE: The following procedure requires that the mirror housing be no colder than 60°F (18°C).

1. Thoroughly clean the plastic mirror housing and the inside surface of the MirrorBeam housing using a 50/50 mixture of isopropyl (Not rubbing) alcohol and water. Dry completely.
2. Locate the two, 6" strips of double-sided adhesive tape included with your MirrorBeam.
3. Trim one of the strips to a length of 5 inches and position on the top of the mirror assembly. When properly positioned, the tape will be centered between the inboard and outboard ends of the mirror housing and the leading edge of the tape will be set back approximately 1/4" from the rear (mirror side) edge of assembly. After the tape is positioned, it is important to apply pressure to the protective backing so the tape adheres to the surface.
4. Cut the remaining 6" length of tape in half. Using the procedure outlined in the previous step, adhere one 3" length of tape to the bottom of the mirror housing and the remaining 3" length to the outside vertical edge of the mirror assembly. As with the top piece, the leading edge of these tape strips will be set back approximately 1/4" from the rear (mirror side) edge of the assembly.
5. Fold the protective backing strips on the top and bottom tape strips so that 1/2" to 3/4" of backing is extended over the edge of the mirror housing. Trim and remove the exposed tape. Remove the protective backing completely from the tape strip on the end of the mirror.
6. Place the mirror housing mirror-side down on your work area. Lower the MirrorBeam housing onto the mirror housing until the MirrorBeam is also in contact with the work table. **The housing must fully engage the mirror assembly!** Press the housing firmly onto the mirror housing.

Fig. 1

This distance must be measured on an angle parallel with line "A".

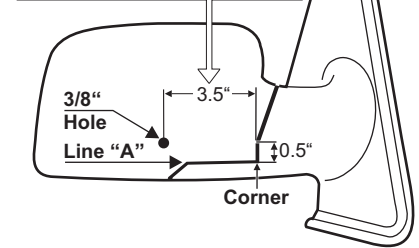
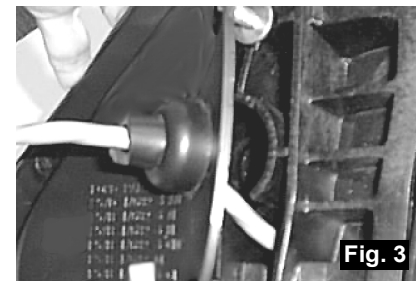
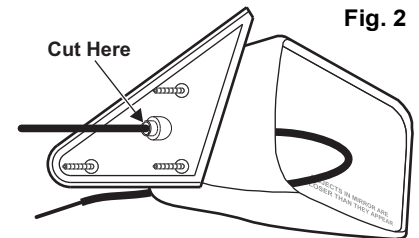

Fig. 2



7. The remaining protective backing strips must now be removed. To accomplish this, the housing must not be in contact with the backing strips. Starting with the bottom strip, and using a small, flat blade screwdriver (or similar tool) gently pry the housing about 1/4" away from the mirror housing. Carefully pull the protective strip "tab" created in step 6, and gently remove it completely from the tape strip. Do not allow the strip to tear while being removed.
8. Repeat for the tape strip on the top of the housing.
9. Apply pressure to the MirrorBeam at the tape locations. Maintain pressure for a minimum of 20 minutes to allow the tape to properly setup. This can be accomplished by wrapping the MirrorBeam tightly with adhesive tape. **IMPORTANT!** The tape adhesive used in this procedure is fully bonded after 72 hours @ 70°F (21°C). During this period, do not expose the MirrorBeam to any un-necessary force, such as high-pressure from a car wash.
10. Locate the factory-drilled hole in the MirrorBeam housing. Using a 1/8" drill bit and the MirrorBeam housing as a template, drill a hole into the mirror housing. Locate the #8 x 1/2" sheet metal screw (included) and secure the MirrorBeam housing to the mirror housing.

Re-assembling the MirrorBeam Assembly:

1. Route the MirrorBeam harness through the door, along the same path as the vehicle's main power harness and finally to the strobe power supply mounted in the vehicle.
2. Cut the non-insulated wire off the strobe harness. Insert the PIN-type terminals into the provided connector as detailed in the "Routing the strobe harness..." section of this manual. Insert plug into power supply and confirm proper strobe operation.
3. Using the original hardware, remount the mirror onto the vehicle.

NOTE: The outer surfaces of this product may be cleaned with mild soap and water. Use of any other chemicals may void product warranty. Do not use a pressure washer.

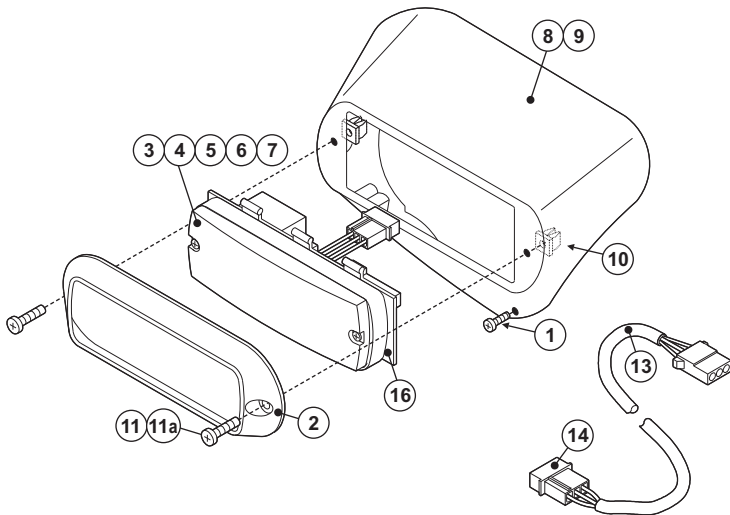
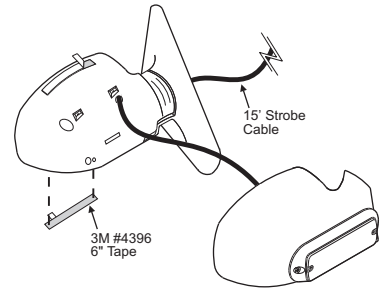

| QTY. | QTY. | ITEM | PART NUMBER | DESCRIPTION |
|------|------|------|----------------|--|
| | * | | 01-06836094__S | MIRROR BEAM / PASSENGER SIDE / STROBE - EXPLORER |
| * | | | 01-06836084__S | MIRROR BEAM / DRIVER SIDE / STROBE - EXPLORER |
| 1 | 1 | 1 | 15-08141A-080 | SCREW / #8 X 1/2" P.P.H.S.M.S. BLACK PHOS. |
| 1 | 1 | 2 | 11-763226-000 | BLACK FLANGE |
| - | A/R | 3 | 68-3963228-50 | LENS / REPLACEMENT / NON-OPTIC / RED |
| - | A/R | 4 | 68-3963228-40 | LENS / REPLACEMENT / NON-OPTIC / GREEN |
| - | A/R | 5 | 68-3963228-30 | LENS / REPLACEMENT / NON-OPTIC / CLEAR |
| - | A/R | 6 | 68-3963228-20 | LENS / REPLACEMENT / NON-OPTIC / BLUE |
| - | A/R | 7 | 68-3963228-10 | LENS / REPLACEMENT / NON-OPTIC / AMBER |
| 1 | - | 8 | 11-483111-L00 | HOUSING / DRIVER SIDE - EXPLORER |
| - | 1 | 9 | 11-483111-R00 | HOUSING / PASSENGER SIDE / EXPLORER |
| 2 | 2 | 10 | 21-12080905-1 | #8 SCREW GROMMET |
| 2 | 2 | 11 | | SCREW / #8 X 5/8" P.P.H.S.M.S.-S.S. |
| 2 | 2 | 11a | | SCREW / 10-24 X3/4" P.P.H.M.S. |
| 2 | 2 | 12 | 66-0416642-00 | MOUNTING TAPE (NOT SHOWN) |
| 1 | 1 | 13 | 46-0742172-15 | 3/C CABLE ASSEMBLY |
| 1 | 1 | 14 | 01-0415532-00 | CABLE INSTALLATION KIT |
| 1 | 1 | 15 | 26-0315001-14 | 14 1/2" BLACK TY-WRAP (NOT SHOWN) |
| 1 | 1 | 16 | 02-0363292-00 | LINEAR STROBE REFLECTOR ASSEMBLY |

NOTE: If your housing contains pressed-in metal threaded inserts, use item 11 to secure the lighthead. If it does not use items 10 and 11a to secure the lighthead.

Vehicle Power Harness:

If your vehicles power harness has a connector like the one shown in this section, you will have to follow a special installation procedure as described below.

WARNING: The installation of this product on vehicles equipped with this type of power harness should only be performed by a professional installation technician. Whelen Engineering assumes no responsibility or liability for damage caused to the vehicle or any of its components by this installation.

1. To gain access to the vehicle power harness, first remove the door panel and radio speaker. (See manufacturers instructions)
2. Find the power harness connector. (Fig. 5.) Remove the rubber cap on top of the connector cover and remove the bolt underneath (Fig. 6A) that holds the connector together.
3. Pull the bottom part of the connector apart (Fig. 6B) and remove the 2 retaining screws that hold the upper part of the connector onto the door (Fig. 6C).
4. Next push the top part of the connector through the door, (Fig. 6D) toward the speaker area and remove the cover.

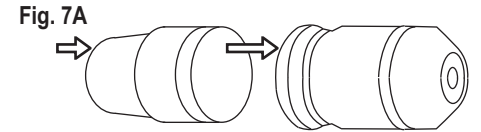
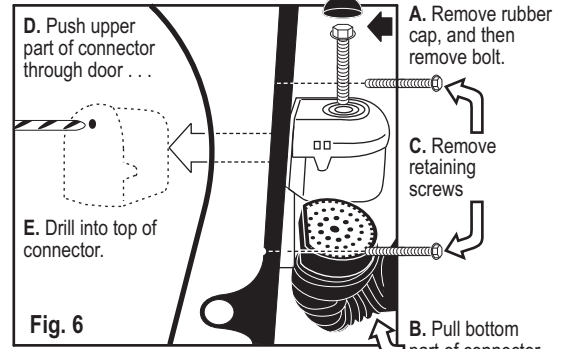
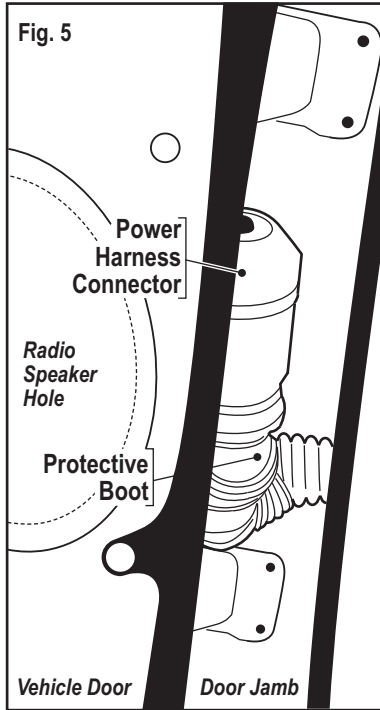

CAUTION: Be sure you drill straight into the connector. If you drill at an angle you will damage the wires inside the connector.

5. Using a 5/16" drill, drill a hole through the power connector in the *center hole of the three unused wire holes*, opposite the flat part of the connector as shown in figure 7. **CAUTION:** Be sure you drill straight into the power connector or you will damage the wires inside.
6. With the top part of the connector inside the door, pull the wires away from the area to be drilled. (This will be the area that lines up with the other hole you drilled in the bottom half of the connector opposite the flat spot.) Drill the hole using a 5/16" drill bit. (Fig. 6E) (You must drill straight into the upper connector as you did on the other half.)
7. Now take the wire coming from the mirrorbeam and snake it through the connector and out the other side in the path shown in Fig. 8.
8. Continue to route the mirrorbeam wire along the path of the vehicles main power harness and finally to the power supply mounted in the vehicle.

