

WHELEN[®]

ENGINEERING COMPANY INC.

Route 145, Winthrop Road,

Chester, Connecticut 06412

Phone: (860) 526-9504

Fax: (860) 526-4078

Internet: www.whelen.com

Sales e-mail: autosale@whelen.com

Canadian Sales e-mail: autocan@whelen.com

Customer Service e-mail: custserv@whelen.com

Installation Guide Traffic Advisor Model TA58LED

Safety First

This document provides all the necessary information to allow your Whelen product to be properly and safely installed. Before beginning the installation and/or operation of your new product, the installation technician and operator must read this manual completely. Important information is contained herein that could prevent serious injury or damage.

- **Proper installation of this product requires the installer to have a good understanding of automotive electronics, systems and procedures.**
- **If mounting this product requires drilling holes, the installer MUST be sure that no vehicle components or other vital parts could be damaged by the drilling process. Check both sides of the mounting surface before drilling begins. Also de-burr any holes and remove any metal shards or remnants. Install grommets into all wire passage holes.**
- **If this product is mounted with tape or Velcro™, clean the mounting surface with a 50/50 mix of isopropyl alcohol and water and dry thoroughly.**
- **Do not install this product or route any wires in the deployment area of your air bag. Equipment mounted or located in the air bag deployment area will damage or reduce the effectiveness of the air bag, or become a projectile that could cause serious personal injury or death. Refer to your vehicle owners manual for the air bag deployment area. The User/Installer assumes full responsibility to determine proper mounting location, based on providing ultimate safety to all passengers inside the vehicle.**
- **For this product to operate at optimum efficiency, a good electrical connection to chassis ground must be made. The recommended procedure requires the product ground wire to be connected directly to the NEGATIVE (-) battery post.**
- **If this product uses a remote device to activate or control this product, make sure that this control is located in an area that allows both the vehicle and the control to be operated safely in any driving condition.**
- **Do not attempt to activate or control this device in a hazardous driving situation.**
- **This product contains either strobe light(s), halogen light(s), high-intensity LEDs or a combination of these lights. Do not stare directly into these lights. Momentary blindness and/or eye damage could result.**
- **Use only soap and water to clean the outer lens. Use of other chemicals could result in premature lens cracking (crazing) and discoloration. Lens in this condition have significantly reduced effectiveness and should be replaced immediately. Inspect and operate this product regularly to confirm its proper operation and mounting condition. Do not use a pressure washer to clean this product.**
- **It is recommended that these instructions be stored in a safe place and referred to when performing maintenance and/or reinstallation of this product.**
- **FAILURE TO FOLLOW THESE SAFETY PRECAUTIONS AND INSTRUCTIONS COULD RESULT IN DAMAGE TO THE PRODUCT OR VEHICLE AND/OR SERIOUS INJURY TO YOU AND YOUR PASSENGERS!**

Mounting the TA58LED Lightbar: *Selecting a Mounting Location*

- Be sure you can get behind the mounting area to attach and secure the mounting nuts.
- When routing the wires, it is important to choose a path that will keep these wires away from excessive heat and from any vehicle equipment that could compromise the integrity of the wires (ex. trunk lids, door jams, etc.).
- When the best mounting location has been determined, securely fasten the unit to its mounting surface using the supplied hardware.

CAUTION: As it will be necessary to drill holes into the mounting surface, the installer **MUST** be sure that no vehicle components or other vital parts could be damaged by the drilling process. Check both sides of the mounting surface before drilling begins!

WARNING! When the Traffic Advisor is mounted to the rear of the vehicle, the cable exit must be on the passenger side. If not, the flash pattern sequence you choose on the control head will be incorrect. For example a left flashing pattern will flash right.

1. The TA58LED attaches to the vehicle by the four 2" bolts extending from the rear of the housing.
2. Position the unit in its proposed mounting location to ensure that it fits properly. With the unit in place, use an awl or other suitable tool and scribe the areas to be drilled.
3. Remove the unit from its mounting area and, using an appropriately sized drill bit, drill a hole in each of the areas scribed in the previous step.
4. Return the unit to its mounting location and using the supplied hardware, mount the unit.

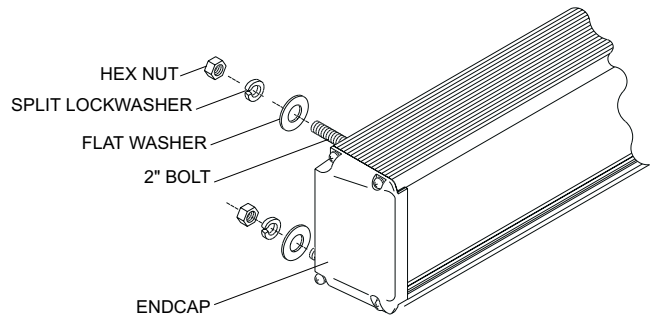

NOTE! do not install the 10 amp fuse required in the fuse block, until *all* wire connections are completed.

The **TACTRL1 Control Head** is used to operate the TA model represented in this manual. A four function rotary switch selects from: left arrow, right arrow, split arrow, or flash pattern. The Dip switch on the rear panel selects the choice of the following patterns:

- One Lamp Sequence to Double Flash
- One Lamp Sequence to Triple Flash
- Two Lamp Sequences
- Three Lamp Sequences
- Four Lamp Sequences
- Sequence On/Sequence Off
- Sequence to Solid
- Solid Arrow

(For setting information, see "Dip Switch Specifications" on page 4)

A Center-Off Rocker Switch is used to turn the unit On and Off, in either High or Low power mode. The TACTRL1 also features an LED status display that provides a visual indication of the current light pattern (Fig. 1).

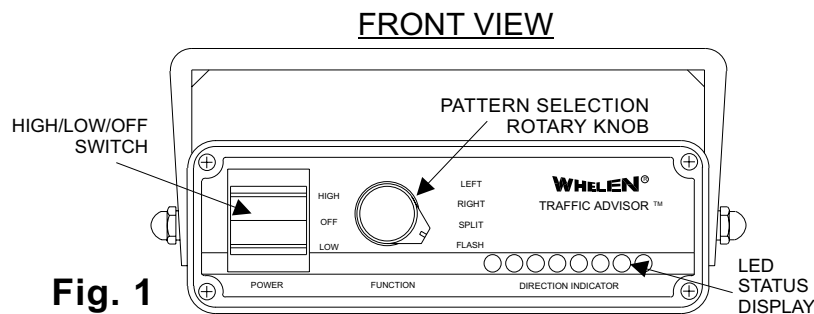

Fig. 1

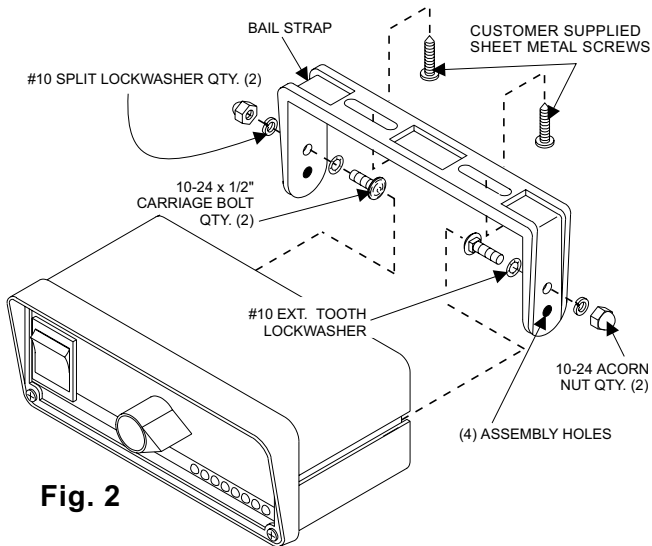

Fig. 2

Installation:

Mounting Control Head

1. Position the bail strap in the selected mounting location. Using an awl or other suitable tool, scribe the surface where the mounting holes are to be drilled.

CAUTION: As mounting the Tactrl1 will require drilling, it is absolutely necessary to make sure that no other vehicle components could be damaged in the process. Check both sides of the mounting surface before starting and if damage is likely, select a different mounting location.

2. Carefully drill the mounting holes in the areas scribed in step one. The size of the drill bit should be determined by the size of the mounting hardware (customer supplied) and the thickness of the mounting surface.
3. Using the customer supplied mounting hardware, secure the bail strap to the mounting location.

NOTE: There are two sets of holes on either side of the Bail Strap that can be used when installing the TACTRL1, to position the control head at two different heights (Fig. 2).

4. With the bail strap in place, insert the carriage bolt along with the external tooth lockwasher (supplied) into the assembly hole from the inner side of the Bail Strap as shown in figure 2.
5. Place the split lockwasher and the acorn nut on the protruding bolt on the outer side of the bail strap. Loosely secure the acorn nut to the carriage bolt.
6. Slide the control head onto the carriage bolts. Once it is in the desired position, tighten the acorn nuts until the unit is firmly secured.

Wiring the Traffic Advisor System

1. Insert the 3-position connector into the back of the control head (see Fig. 3).
2. Extend the RED and BLACK wires to the battery.
3. Connect the RED wire to one end of a user supplied fuse block. *DO NOT connect this unit to the battery yet!*
4. Connect the BLACK wire to the vehicle's chassis ground.
5. Extend and connect the WHITE wire to to the dash board light circuit. or an electrical connection that is live when the vehicle is turned on.
6. With the control head wired, route the cable from the TA to the control head. (See Below)
7. Following the pin chart (Fig. 4), insert the contact wires into their given positions. Check the wire's retention fingers by pulling back on them with a force of 1 or 2 lbs. to make sure that they are holding the contact.
8. Plug 12-position connector into the back of the control head.

The installation of your Traffic Advisor System will be complete after the fuse block wire is connected to the POSITIVE (+) terminal of the battery. After this connection has been made, inspect the fuses at the control head and at the battery. If either of these fuses are blown, carefully inspect all of the circuit wires and make sure they are wired correctly. Replace the blown fuses with one of an identical amp rating as the original. If these fuses blow after installation or activation, contact Whelen Engineering Technical Support.

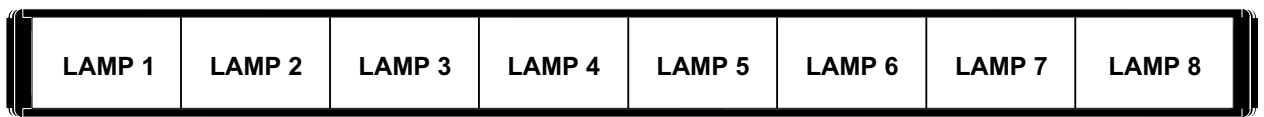

TA58LED / FRONT VIEW

TA-58LED TO TACTRL 1 CONNECTIONS

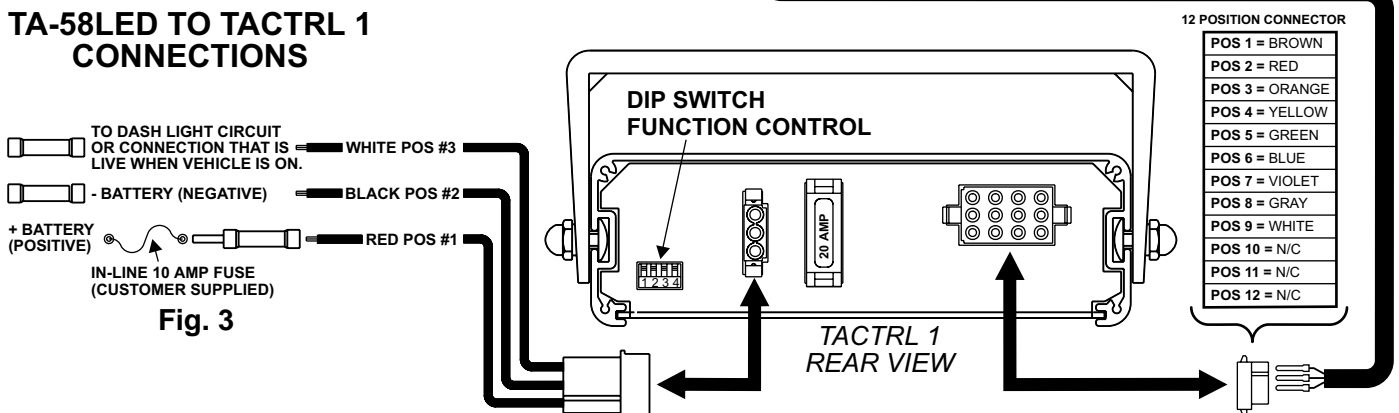
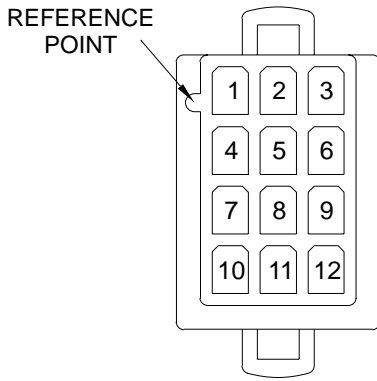

Fig. 3

Fig. 4



Rear View of Pin Housing

PIN	TO:	WIRE	PIN	TO:	WIRE
1	LAMP 1	BROWN	7	LAMP 7	VIOLET
2	LAMP 2	RED	8	LAMP 8	GREY
3	LAMP 3	ORANGE	9	+BATTERY	WHITE
4	LAMP 4	YELLOW	10	N/C	N/C
5	LAMP 5	GREEN	11	N/C	N/C
6	LAMP 6	BLUE	12	N/C	N/C

WARNING: All customer supplied wires, that connect to the positive terminal of the battery, must be sized to supply at least 125% of the maximum operating current, and fused "At the Battery" to carry the load.

Dip Switch Specifications...

Configuration #1 (Default) = All Down

Pattern Control Knob = **LEFT**

Individual lamps light sequentially from Left to Right with the last lamp displaying a triple flash pattern. EX. 2 - 3 - 4 - 5 - 6 - 7 - 8 - 8 - 8

Pattern Control Knob = **RIGHT**

Individual lamps light sequentially from Right to Left with the last lamp displaying a triple flash pattern. EX. 7 - 6 - 5 - 4 - 3 - 2 - 1 - 1 - 1

Pattern Control Knob = **SPLIT**

Lamps light in pairs that begin in the middle and move outwards with the last two lamps displaying a triple flash pattern. EX. 4+5 - 3+6 - 2+7 - 1+8 - 1+8 - 1+8

Pattern Control Knob = **FLASH**

Alternating pairs of lamp light. EX. 4+5 - 2+7

Configuration #2 = 1,2,4 Down / 3 Up

Pattern Control Knob = **LEFT**

Individual lamps light sequentially from Left to Right with the last lamp displaying a Double Flash Pattern. EX. 2 - 3 - 4 - 5 - 6 - 7 - 8 - 8

Pattern Control Knob = **RIGHT**

Individual lamps light sequentially from Right to Left with the last lamp displaying a Double Flash Pattern. EX. 7 - 6 - 5 - 4 - 3 - 2 - 1 - 1

Pattern Control Knob = **SPLIT**

Lamps light in pairs that begin in the middle and move outwards with the last two lamps displaying a Double Flash Pattern. EX. 4+5 - 3+6 - 2+7 - 1+8 - 1+8

Pattern Control Knob = **FLASH**

Alternating pairs of lamp light using a double flash sequence. EX. 4+5 - 4+5 - 2+7 - 2+7

Configuration #3 = 1,2,4 Down / 3 Up

Pattern Control Knob = **LEFT**

Lamps light progressively from Left to Right with lamps remaining on until the pattern repeats. EX. 2>3>4>5>6>7>8

Pattern Control Knob = **RIGHT**

Lamps light progressively from Right to Left with lamps remaining on until the pattern repeats. EX. 7>6>5>4>3>2>1

Pattern Control Knob = **SPLIT**

Lamps light in pairs that begin in the middle and move outwards with lamps remaining on until the pattern repeats. EX. 4+5>3+6>2+7>1+8

Pattern Control Knob = **FLASH**

Alternating pairs of lamp light using a double flash sequence. EX. 4+5 - 4+5 - 2+7 - 2+7

Configuration #4 = 1,2 Down / 3,4 Up

Pattern Control Knob = **LEFT**

Lamps light in a solid flash pattern. EX. 2 - 8 Flash Simultaneously

Pattern Control Knob = **RIGHT**

Lamps light in a solid flash pattern. EX. 7 - 1 Flash Simultaneously

Pattern Control Knob = **SPLIT**

Lamps light in a solid flash pattern. EX. 1 - 8 Flash Simultaneously

Pattern Control Knob = **FLASH**

Alternating pairs of lamp light using a double flash sequence. EX. 4+5 - 4+5 - 2+7 - 2+7

(Continued on Next Page)

Configuration #4 = 1,2 Down / 3,4 Up

Pattern Control Knob = **LEFT**

Lamps light in a solid flash pattern. EX. 2 - 8 Flash Simultaneously

Pattern Control Knob = **RIGHT**

Lamps light in a solid flash pattern. EX. 7 - 1 Flash Simultaneously

Pattern Control Knob = **SPLIT**

Lamps light in a solid flash pattern. EX. 1 - 8 Flash Simultaneously

Pattern Control Knob = **FLASH**

Alternating pairs of lamp light using a double flash sequence. EX. 4+5 - 4+5 - 2+7 - 2+7

Configuration #5 = 1,3,4 Down / 2 Up

Pattern Control Knob = **LEFT**

Individual lamps light progressively from Left to Right. EX. 2 - 2+3 - 3+4 - 4+5 - 5+6 - 6+7 - 7+8 - 8

Pattern Control Knob = **RIGHT**

Individual lamps light progressively from Right to Left. EX. 7 - 7+6 - 6+5 - 5+4 - 4+3 - 3+2 - 2+1 - 1

Pattern Control Knob = **SPLIT**

Lamps light in pairs that begin in the middle and move progressively outwards. EX. 4+5 - 3+4+5+6 - 2+3+6+7 - 1+2+7+8 - 1+8

Pattern Control Knob = **FLASH**

Alternating pairs of lamp light using a double flash sequence. EX. 4+5 - 4+5 - 2+7 - 2+7

Configuration #6 = 1,3 Down / 2,4 Up

Pattern Control Knob = **LEFT**

Individual lamps light in groups of 3 progressively from Left to Right. EX. 2 - 2+3 - 2+3+4 - 3+4+5 - 4+5+6 - 5+6+7 - 6+7+8 - 7+8 - 8 - 8

Pattern Control Knob = **RIGHT**

Individual lamps light in groups of 3 progressively from Right to Left. EX. 7 - 7+6 - 7+6+5 - 6+5+4 - 5+4+3 - 4+3+2 - 3+2+1 - 2+1 - 1 - 1

Pattern Control Knob = **SPLIT**

Lamps light in groups that begin in the middle and move progressively outwards. EX. 4+5 - 3+4+5+6 - 2+3+4+5+6+7 - 1+2+3+6+7+8 - 1+2+7+8 - 1+8 - 1+8

Pattern Control Knob = **FLASH**

Alternating pairs of lamp light using a double flash sequence. EX. 4+5 - 4+5 - 2+7 - 2+7

Configuration #7 = 1,4 Down / 2,3 Up

Pattern Control Knob = **LEFT**

Individual lamps light in groups of 4 progressively from Left to Right. EX. 2 - 2+3 - 2+3+4 - 2+3+4+5 - 3+ 4+5+6 - 4+5+6+7 -

5+6+7+8 - 6+7+8 - 7+8 - 8

Pattern Control Knob = **RIGHT**

Individual lamps light in groups of 4 progressively from Right to Left. EX. 7 - 7+ 6 - 7+6+5 - 7+6+5+ 4 -6+5+4+3 - 5+4+3+2 - 4+3+2+1 - 3+2+1 - 2+1 - 1

Pattern Control Knob = **SPLIT**

Lamps light in groups that begin in the middle and move progressively outwards. EX. 4+5 - 3+4+5+6 - 2+3+4+5+6+7 - 1+2+3+4+5+6+7+8 - 1+2+3+6+7+8 - 1+2+7+8 - 1+8 - 1+8

Pattern Control Knob = **FLASH**

Alternating pairs of lamp light using a double flash sequence. EX. 4+5 - 4+5 - 2+7 - 2+7

Configuration #8 = 1,2,3,4 Up

Pattern Control Knob = **LEFT**

Lamps light progressively from Left to Right forming a solid arrow and terminate progressively in that same order. EX. 2 > 2+3 > 2+3+4 > 2+3+4+5 > 2+3+4+5+6 > 2+3+4+5+6+7 > 2+3+4+5+6+7+8 > 3+4+5+6+7+8 > 4+5+6+7+8 > 5+6+7+8 > 6+7+8 > 7+8 > 8

Pattern Control Knob = **RIGHT**

Lamps light progressively from Right to Left forming a solid arrow and terminate progressively in that same order. EX. 7 > 7+6 > 7+6+5 > 7+6+5+4 > 7+6+5+4+3 > 7+6+5+4+3+2 > 7+6+5+4+3+2+1 > 6+5+4+3+2+1 > 5+4+3+2+1 > 4+3+2+1 > 3+2+1 > 2+1 > 1

Pattern Control Knob = **SPLIT**

Lamps light progressively in pairs that begin in the middle and move outwards activating all lamp and terminate progressively in that same order. EX. 4+5 > 3+4+5+6 > 2+3+4+5+6+7 > 1+2+3+4+5+6+7+8 > 1+2+3+6+7+8 > 1+2+7+8 > 1+8 > 1+8

Pattern Control Knob = **FLASH**

Alternating pairs of lamp light using a double flash sequence. EX. 4+5 - 4+5 - 2+7 - 2+7

NOTE: When dip switch #1 is placed in the on position the lamp configuration changes from an 8 lamp array to a 6 lamp array.

Dip switches set for a 6 light sequence

