

ISAE SERIES BEACONS

ISAE120, 120 VOLTS AC

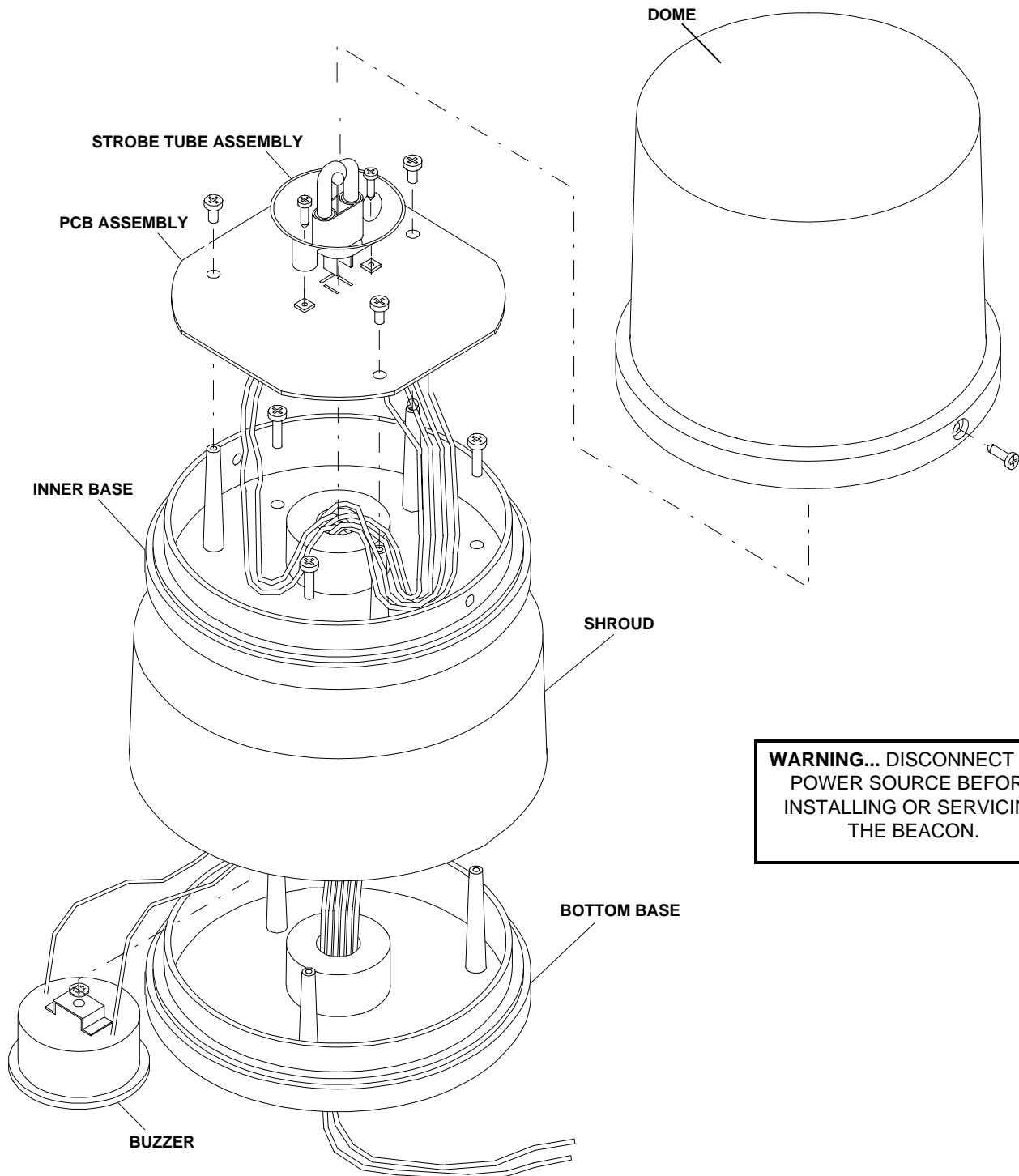

WARNING... DISCONNECT THE
POWER SOURCE BEFORE
INSTALLING OR SERVICING
THE BEACON.

REPLACEMENT PARTS LIST FOR ISAE SERIES BEACONS

DESCRIPTION	QTY.	PART NUMBER	ISAE120
STROBE TUBE ASSEMBLY	1	36-0341567-00	■
BUZZER, 120VAC	1	43-0212116600	■
PCB ASSEMBLY, ISAE	1	02-0168511-00	■
DOME, AMBER	1	68-4180452-10	■
DOME, BLUE	1	68-4180452-20	■
DOME, CLEAR	1	68-4180452-30	■
DOME, GREEN	1	68-4180452-40	■
DOME, RED	1	68-4180452-50	■

MOUNTING & WIRING INSTRUCTIONS

The ISAE Series of Beacons are designed for mounting to a pendant with a 1" NPT thread or surface mounting to a flat area.

PIPE MOUNT

1. Feed the power source cable through the pipe.
2. Connect the GREEN wire to the AC service green wire (ground).
3. Connect the BLACK wire to the AC service black wire (hot).
4. Connect the WHITE wire to the AC service white wire (neutral).
5. Mount the Beacon to the pipe threads. Make sure that the power wires are not pinched or severely twisted. Do not over-torque the plastic base.

SURFACE MOUNT

1. The Beacon must be disassembled in order to mount the Base to a flat surface. Remove the dome screws. Each screw has a small O-ring. Do not loose the O-rings. Remove the Dome.
2. Remove (3) screws that hold the PCB Assembly to the Inner Base. Remove (3) screws that hold the Inner Base to the Bottom Base.
3. Use the Bottom Base as a template. Locate (3) mounting holes and mark the locations on the mounting surface. Mount the Bottom Base.
4. Feed the power source cable to the Beacon.
5. Connect the GREEN wire to the AC service green wire (ground).
6. Connect the BLACK wire to the AC service black wire (hot).
7. Connect the WHITE wire to the AC service white wire (neutral).
8. Re-assemble the Beacon.

STROBE TUBE REPLACEMENT

1. Disconnect power. Wait 10 minutes, for power supply to discharge.
2. Remove the dome screws. Each screw has a small O-ring. Do not loose the O-rings. Remove the Dome.
3. Remove two screws from Strobe Tube Assembly. Grasp the plastic part of the Strobe Tube Assembly and gently pull it out of the socket. Replace the Assembly. Re-assemble the unit. Be sure to include the O-rings on each dome screw.