

# WHELEN<sup>®</sup>

ENGINEERING COMPANY INC.

51 Winthrop Road  
Chester, Connecticut 06412-0684  
Phone: (860) 526-9504  
Fax: (860) 526-4078  
Internet: [www.whelen.com](http://www.whelen.com)  
Sales e-mail: [autosale@whelen.com](mailto:autosale@whelen.com)  
Canadian Sales e-mail: [canadiansales@whelen.com](mailto:canadiansales@whelen.com)  
Customer Service e-mail: [custserv@whelen.com](mailto:custserv@whelen.com)

## Installation and Operation Guide: Intelligent Strobe Power Supply Model ISP18824

### Safety First

This document provides all the necessary information to allow your Whelen product to be properly and safely installed. Before beginning the installation and/or operation of your new product, the installation technician and operator must read this manual completely. Important information is contained herein that could prevent serious injury or damage.

- **Proper installation of this product requires the installer to have a good understanding of automotive electronics, systems and procedures.**
- **If mounting this product requires drilling holes, the installer MUST be sure that no vehicle components or other vital parts could be damaged by the drilling process. Check both sides of the mounting surface before drilling begins. Also de-burr any holes and remove any metal shards or remnants. Install grommets into all wire passage holes.**
- **If this manual states that this product may be mounted with suction cups, magnets, tape or Velcro<sup>®</sup>, clean the mounting surface with a 50/50 mix of isopropyl alcohol and water and dry thoroughly.**
- **Do not install this product or route any wires in the deployment area of your air bag. Equipment mounted or located in the air bag deployment area will damage or reduce the effectiveness of the air bag, or become a projectile that could cause serious personal injury or death. Refer to your vehicle owner's manual for the air bag deployment area. The User/Installer assumes full responsibility to determine proper mounting location, based on providing ultimate safety to all passengers inside the vehicle.**
- **For this product to operate at optimum efficiency, a good electrical connection to chassis ground must be made. The recommended procedure requires the product ground wire to be connected directly to the NEGATIVE (-) battery post.**
- **If this product uses a remote device to activate or control this product, make sure that this control is located in an area that allows both the vehicle and the control to be operated safely in any driving condition.**
- **Do not attempt to activate or control this device in a hazardous driving situation.**
- **It is recommended that these instructions be stored in a safe place and referred to when performing maintenance and/or reinstallation of this product.**
- **FAILURE TO FOLLOW THESE SAFETY PRECAUTIONS AND INSTRUCTIONS COULD RESULT IN DAMAGE TO THE PRODUCT OR VEHICLE AND/OR SERIOUS INJURY TO YOU AND YOUR PASSENGERS!**

**For warranty information regarding this product, visit [www.whelen.com/warranty](http://www.whelen.com/warranty)**

This ISP18824 Intelligent Strobe Power Supply can be installed in many different types of vehicles. The guidelines for the installation of this product are written so that no matter what vehicle is being used, the installation will be simple and straight forward.

### Selecting a Mounting Location:

The logical choice for a mounting area would be a trunk or similar compartment. However, due to the wide variety of vehicles onto which the ISP18824 can be installed, this is not always possible. The following guidelines will help the installer select an alternative:

- A) The unit should be mounted on a metal surface to aid heat dissipation. Be sure that this surface is not one that either generates or is exposed to excessive heat during normal operation of the vehicle.
- B) Do not select a location where the power supply will be exposed to potential damage from any unsecured or loose equipment.
- C) Be sure the area selected will not be exposed to water.
- D) When routing the wires, it is important to choose a path that will keep the wires away from excessive heat or vehicle equipment that could compromise the integrity of the wires (ex. trunk lids, door jams, etc.).
- E) Be sure your mounting location does not block the cooling fan in the rear of the unit. (See last page)

**WARNING! When extending the communication wires (BLUE & GREY), use either the Whelen 25ft cable (P/N 46-9641638-250) or similar "twisted pair" wires.**

**WARNING! All customer supplied wires that connect to the positive terminal of the battery must be sized to supply at least 125% of the maximum operating current and FUSED at the battery to carry that load. DO NOT USE CIRCUIT BREAKERS WITH THIS PRODUCT!**

**Caution: Permanent mounting of this product will require drilling. It is absolutely necessary to make sure that no other vehicle components could be damaged by this process. Check both sides of the mounting surface before starting. If damage is likely, select a different mounting location.**

### Operating Instructions:

The ISP18824 has been designed to emulate the operations of four existing Whelen power supplies:

The UPS-188C / Alternating Pairs ..... ALT 2X2X4  
The DOT-188C / Simultaneous Pairs .....SIMUL. 2X2X4  
The DOT-188MN / Simultaneous .....SIMUL. 2X2X4  
The BL188C..... B-LINK

Select the desired operational mode by configuring dip switches #1, 2, 3 & 8, located on the front panel of the power supply. The use of Dip Switches #4 & 5 is explained in the "Hi-Lo Power" section. The following section will explain how to place the ISP18824 into each of these respective modes, as well as outline the operational procedures for each mode.

### Section 1: Emulation Modes:

Applying +24VDC to the control wires indicated in each mode (using customer supplied switches) will cause the results indicated. For a listing of the available flash patterns refer to Section 2: Flash Patterns.

### ALT. 2X2X4 Mode / Default Configuration:

#### Dip Switches

The dip switch configuration for UPS188C-mode is:

Switch 1 - OFF Switch 2 - OFF Switch 3 - OFF Switch 8 - OFF

#### Control Wires

Wire #1 = Outlets 1 & 2 Enabled Wire #2 = Outlets 3 & 4 Enabled  
Wire #3 = 5, 6, 7 & 8 Enabled

### SIM 2X2X4 Mode:

#### Dip Switches

The dip switch configuration for DOT-188C mode is:

Switch 1 - ON Switch 2 - OFF Switch 3 - OFF Switch 8 - OFF

#### Control Wires

Wire #1 = Outlets 1 & 3 Enabled Wire #2 = Outlets 5 & 7 Enabled  
Wire #3 = 2, 4, 6 & 8 Enabled

### SIM 2X2X4MN Mode:

#### Dip Switches

The dip switch configuration for DOT188MN Mode:

Dip Switch 1 - OFF Dip Switch 3 - OFF  
Dip Switch 2 - ON Dip Switch 8 - OFF

#### Control Wires

Control Wire #1 = Outlets 2 & 4 Enabled  
Control Wire #2 = Outlets 6 & 8 Enabled  
Control Wire #3 = Outlets 1, 3, 5 & 7 Enabled

### ALT 2X2X2X2 Mode:

#### Dip Switches

The dip switch configuration for ALT 2X2X2X2 Mode:

Dip Switch 1 - ON Dip Switch 3 - OFF  
Dip Switch 2 - ON Dip Switch 8 - OFF

### BL188C Mode:

When the ISP18824 is configured to emulate the BL188C, it is important to understand that the connections and operational procedures used are different from any of the other modes.

#### Dip Switches

BL188C emulation is accomplished by placing Dip Switch 8 in the ON position. At this point, the remaining Dip Switches (1 thru 3) are used to configure the address of the ISP18824 for use in a B-LINK system. The addressing properties function as follows:

#### To Configure Address 1: To Configure Address 2:

Dip Switch 1 - ON Dip Switch 1 - OFF  
Dip Switch 2 - OFF Dip Switch 2 - ON  
Dip Switch 3 - OFF Dip Switch 3 - OFF

#### To Configure Address 3

Dip Switch 1 - OFF Dip Switch 2 - OFF Dip Switch 3 - ON

#### Control Wires

In this configuration, control wires 1, 2, 3 & 4 are not used to enable outlets or control Hi/Lo power activation, as with the previous modes. Outlet control and Hi/Lo power activation is handled by the B-LINK Multi-Purpose Controller.

### Section 2: Flash Patterns

The ISP18824 can generate any of 16 available flash patterns simply activating the 4 Pattern Control wires, either individually or in combination. Table 1 on Page 3 outlines all of the available patterns and the wire activations needed to produce them.

### Section 3: Hi/Lo Power

Hi/Lo power activation and functionality can be configured in any of 4 modes, depending upon how Dip Switches 4 & 5 are positioned. Table 2 on Page 3 outlines each of the 4 configurations and their attributes.

**NOTE:** In BL188C emulation mode, Hi/Lo power activation is controlled with a B-LINK Multi-Purpose Controller.

### Section 4: Diagnostix™ / Optional

The optional Diagnostix™ display allows the operator to confirm proper operation of not only the 8 outlets on the ISP18824, but of the strobe light and strobe cable connected to these outlets as well. Each LED indicator on the Diagnostix™ display, provides diagnostic information for one outlet. For example; LED #1 monitors Outlet #1, etc. The LED's appearance indicates the condition of it's corresponding outlet. Refer to Table 3 on Page 3.

### Section 5: Phasing

When you turn dip switch 7 on, you will cause outlets 1-4 to drift slowly in and out of sync with outlets 5-8. Lights will work as described in each mode. The result will be a more eye catching or random flash pattern.

**IMPORTANT! It is the responsibility of the installation technician to make sure that the installation and operation of this product will not interfere with or compromise the operation or efficiency of any vehicle equipment!**

# ISP18824 WIRING DIAGRAM

UNIT SPECIFICATIONS	
V-INPUT	25.6VDC ±20%
I-IN 12.8V	9 AMPS (TYP)
FLASHRATE	150 FPM (MIN)
JOULES HI	8/3.5/3.5/3.5 (TYP)
JOULES LO	2/2/2/2 (MIN)
OUTPUT POWER	180 WATTS
OUTPUT PER OUTLET	22.5 WATTS (TYP)

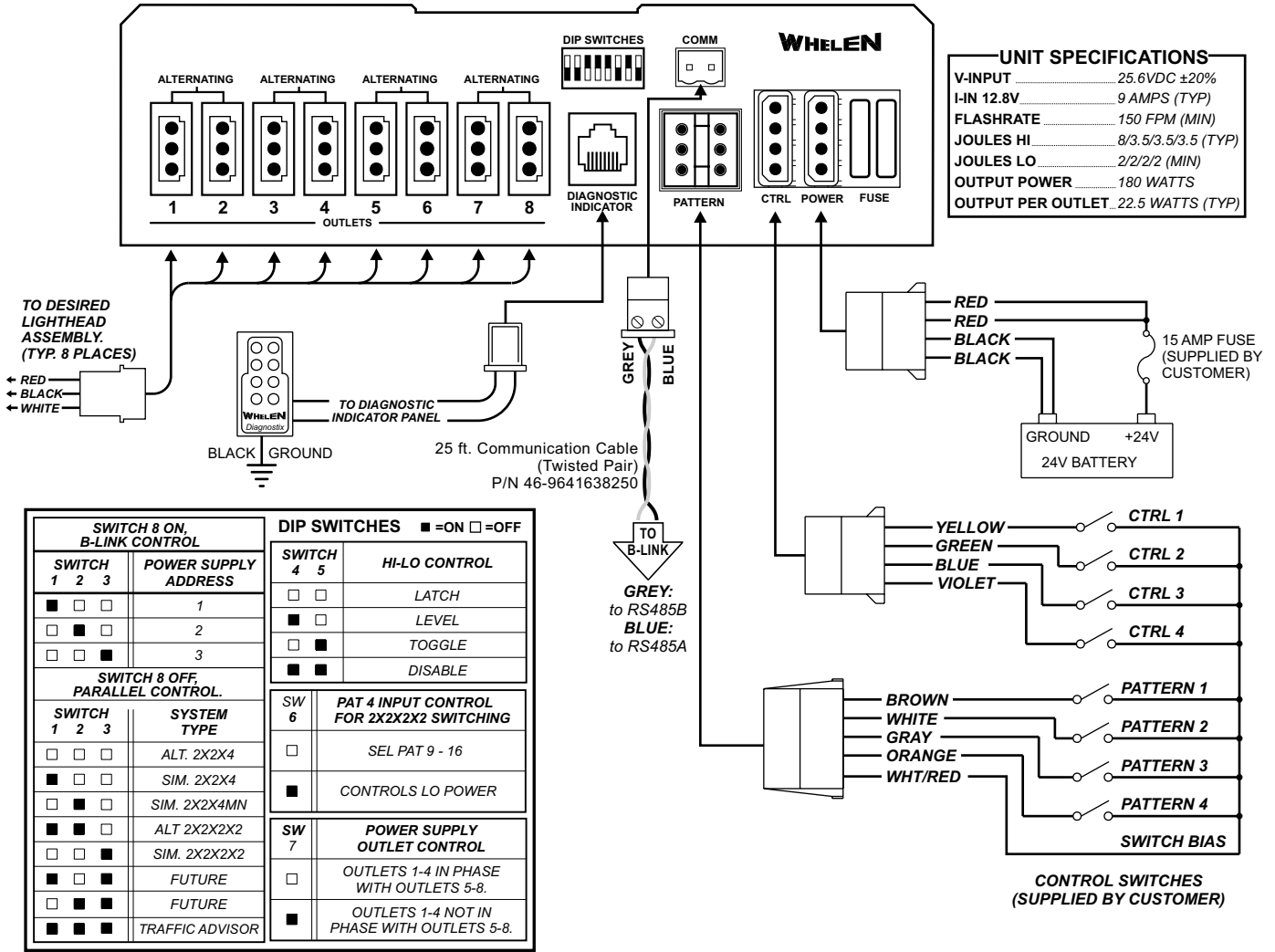

FLASH PATTERNS: ■ = +24VDC	
PATTERN WIRE 1 2 3 4	PATTERN TYPE
□ □ □ □	COMET FLASH
■ □ □ □	TRIPLE FLASH
□ ■ □ □	DOUBLE FLASH
■ ■ □ □	RAPID RANDOM
□ □ ■ □	SEQUENTIAL
■ □ ■ □	MODU-FLASH
□ ■ ■ □	MICRO-BURST 2
■ ■ ■ □	MICRO-BURST 3
□ □ □ ■	2X COMET FLASH
■ □ □ ■	2X TRIPLE FLASH
□ ■ □ ■	2X DOUBLE FLASH
■ ■ □ ■	1/2 RAPID RANDOM
□ □ ■ ■	2X SEQUENTIAL
■ □ ■ ■	2X MODU-FLASH
□ ■ ■ ■	2X MICRO-BURST 2
■ ■ ■ ■	2X MICRO-BURST 3

Pattern Wire 1 = BROWN  
Pattern Wire 2 = WHITE  
Pattern Wire 3 = GREY  
Pattern Wire 4 = ORANGE

**Table 2**

IF THE LED IS...	THEN...
<b>OFF</b>	Either the outlet in question is not enabled, or the power supply is not turned on.
<b>ON continuously</b>	The outlet, strobe cable and strobe light in question are functioning properly.
<b>FLASHING rapidly</b>	Either the outlet, strobe cable and/or strobe light in question are malfunctioning. In this condition, further investigation of the components is strongly recommended
<b>ON continuously with a single flash every few seconds</b>	The ISP18824 is operating in Lo power mode.

**Table 3**

Hi/Lo Mode Type	Recommended Switch type	To Enable Lo Power Operation	To Restore Hi Power Operation	Dip Switch 4	Dip Switch 5
<b>Latched</b>	Momentary	Apply +24VDC to VIOLET control wire	Turn all strobe outlets off and then on.	OFF	OFF
<b>Level</b>	Single Pole/Single Throw	Apply +24VDC to VIOLET control wire	Remove +24VDC from VIOLET control wire	ON	OFF
<b>Toggle</b>	Momentary	Apply +24VDC to VIOLET control wire	Apply +24VDC to VIOLET control wire	OFF	ON
<b>DISABLED</b>	NONE	No Low Power Operation in This Mode	Not Applicable	ON	ON

When mounting this unit keep the rear side clear of obstructions.



When mounting this unit vertically, air must flow up.

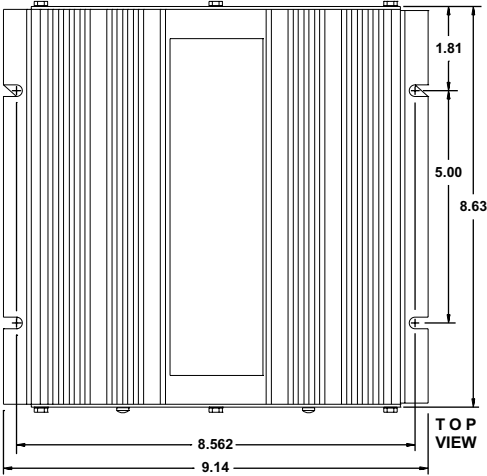

## ISP18824 REPLACEMENT PARTS

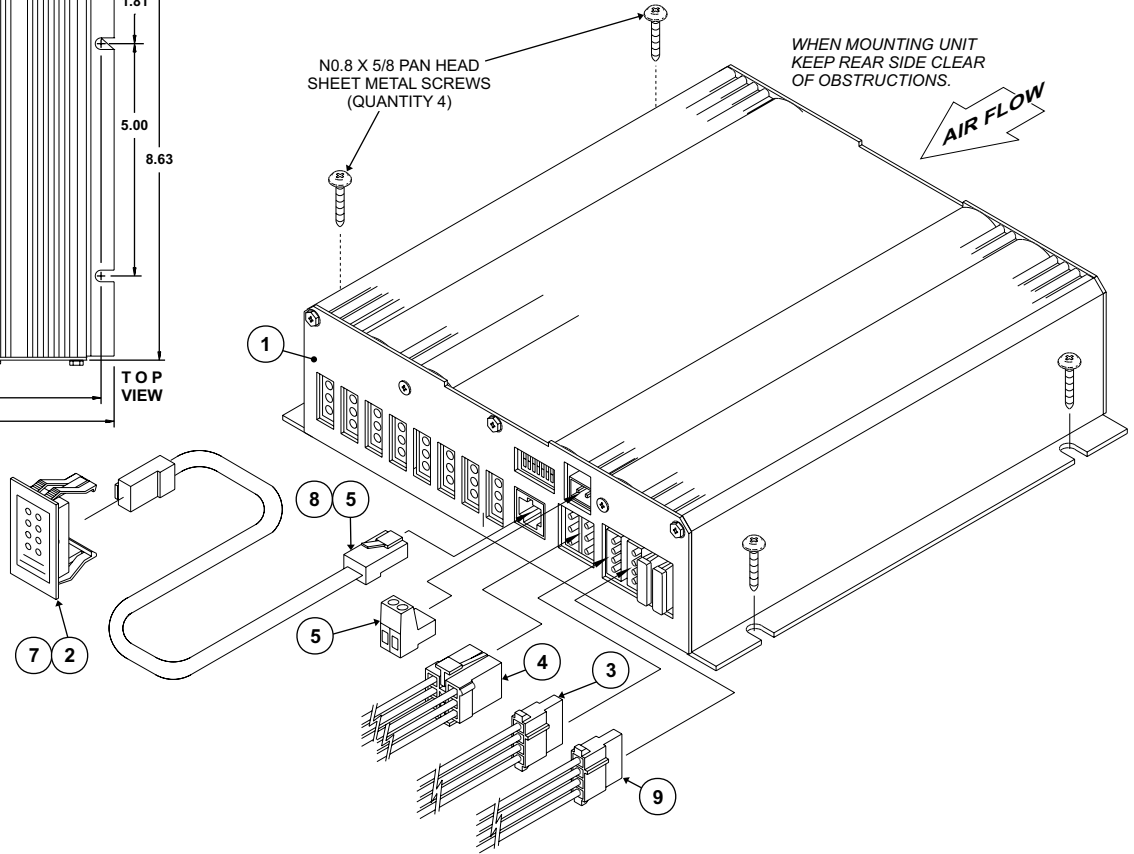

### ISP18824 PARTS LIST

ITEM	PART NUMBER	DESCRIPTION
REF	46-9641638250	25' TWISTED PAIR B-LINK CABLE
9	46-0725612-00	POWER CONNECTOR ASSEMBLY
8	02-0241485-25	CABLE ASSY, 8 POS TELEPHONE 25'
7	01-0267643-00	DOT DIAGNOSTIC INDICATOR ASSEMBLY
6	02-0241485-08	CABLE ASSY, 8 POS TELEPHONE 8'
5	39CIJ02523-IJ	2 POS PHOENIX CONNECTOR
4	46-0725945-00	PATTERN CONNECTOR ASSEMBLY
3	46-0725613-00	CONTROL CONNECTOR ASSEMBLY
2	01-0267265-00	UPS DIAGNOSTIC INDICATOR ASSEMBLY
1	01-0662830-00	ISP18824 FINAL ASSEMBLY
o	01-0683157-00	ISP18824 STROBE POWER SUPPLY

### Traffic Advisor Mode...

#### Dip Switches

The dip switch configuration for Traffic Advisor Mode:

Dip Switch 1 - ON

Dip Switch 2 - ON

Dip Switch 3 - ON

#### Control Wires

In this configuration, applying +24VDC to the control wires (using customer supplied switches) will have the following results:

**Control Wire #1 = LEFT SWEEP**

**Control Wire #2 = RIGHT SWEEP**

**Control Wire #3 = ALTERNATING FLASH**

**Control Wire #2 & #3 = SPLIT SWEEP**

### TRAFFIC ADVISOR

In order for the Traffic Advisor patterns to flash properly, it is necessary for the lamps to be connected to the ISP18824 in the following pattern.

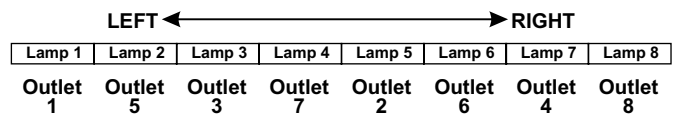

The Traffic Advisor (or T/A) mode is comprised of four, traffic control-oriented flash patterns.

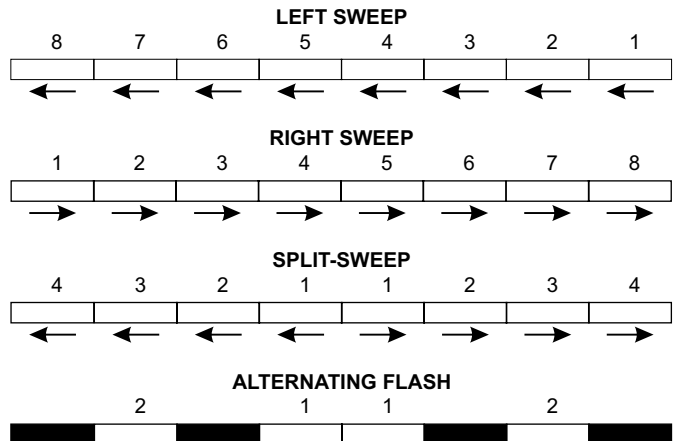

The T/A pattern mode is enabled as indicated in table 2.