

WHELEN[®]

ENGINEERING COMPANY INC.

Route 145, Winthrop Road,

Chester, Connecticut 06412

Phone: (860) 526-9504

Fax: (860) 526-4078

Internet: www.whelen.com

Sales e-mail: autosale@whelen.com

Canadian Sales e-mail: autocan@whelen.com

Customer Service e-mail: custserv@whelen.com

Installation Guide 7E Linear Strobe Lighthouse

Safety First

This document provides all the necessary information to allow your Whelen product to be properly and safely installed. Before beginning the installation and/or operation of your new product, the installation technician and operator must read this manual completely. Important information is contained herein that could prevent serious injury or damage.

- **Proper installation of this product requires the installer to have a good understanding of automotive electronics, systems and procedures.**
- **If mounting this product requires drilling holes, the installer MUST be sure that no vehicle components or other vital parts could be damaged by the drilling process. Check both sides of the mounting surface before drilling begins. Also de-burr any holes and remove any metal shards or remnants. Install grommets into all wire passage holes.**
- **If this product is mounted with tape or Velcro[™], clean the mounting surface with a 50/50 mix of isopropyl alcohol and water and dry thoroughly.**
- **Do not install this product or route any wires in the deployment area of your air bag. Equipment mounted or located in the air bag deployment area will damage or reduce the effectiveness of the air bag, or become a projectile that could cause serious personal injury or death. Refer to your vehicle owners manual for the air bag deployment area. The User/Installer assumes full responsibility to determine proper mounting location, based on providing ultimate safety to all passengers inside the vehicle.**
- **For this product to operate at optimum efficiency, a good electrical connection to chassis ground must be made. The recommended procedure requires the product ground wire to be connected directly to the NEGATIVE (-) battery post.**
- **If this product uses a remote device to activate or control this product, make sure that this control is located in an area that allows both the vehicle and the control to be operated safely in any driving condition.**
- **Do not attempt to activate or control this device in a hazardous driving situation.**
- **This product contains either strobe light(s), halogen light(s), high-intensity LEDs or a combination of these lights. Do not stare directly into these lights. Momentary blindness and/or eye damage could result.**
- **Use only soap and water to clean the outer lens. Use of other chemicals could result in premature lens cracking (crazing) and discoloration. Lenses in this condition have significantly reduced effectiveness and should be replaced immediately. Inspect and operate this product regularly to confirm its proper operation and mounting condition. Do not use a pressure washer to clean this product.**
- **It is recommended that these instructions be stored in a safe place and referred to when performing maintenance and/or reinstallation of this product.**
- **FAILURE TO FOLLOW THESE SAFETY PRECAUTIONS AND INSTRUCTIONS COULD RESULT IN DAMAGE TO THE PRODUCT OR VEHICLE AND/OR SERIOUS INJURY TO YOU AND YOUR PASSENGERS!**

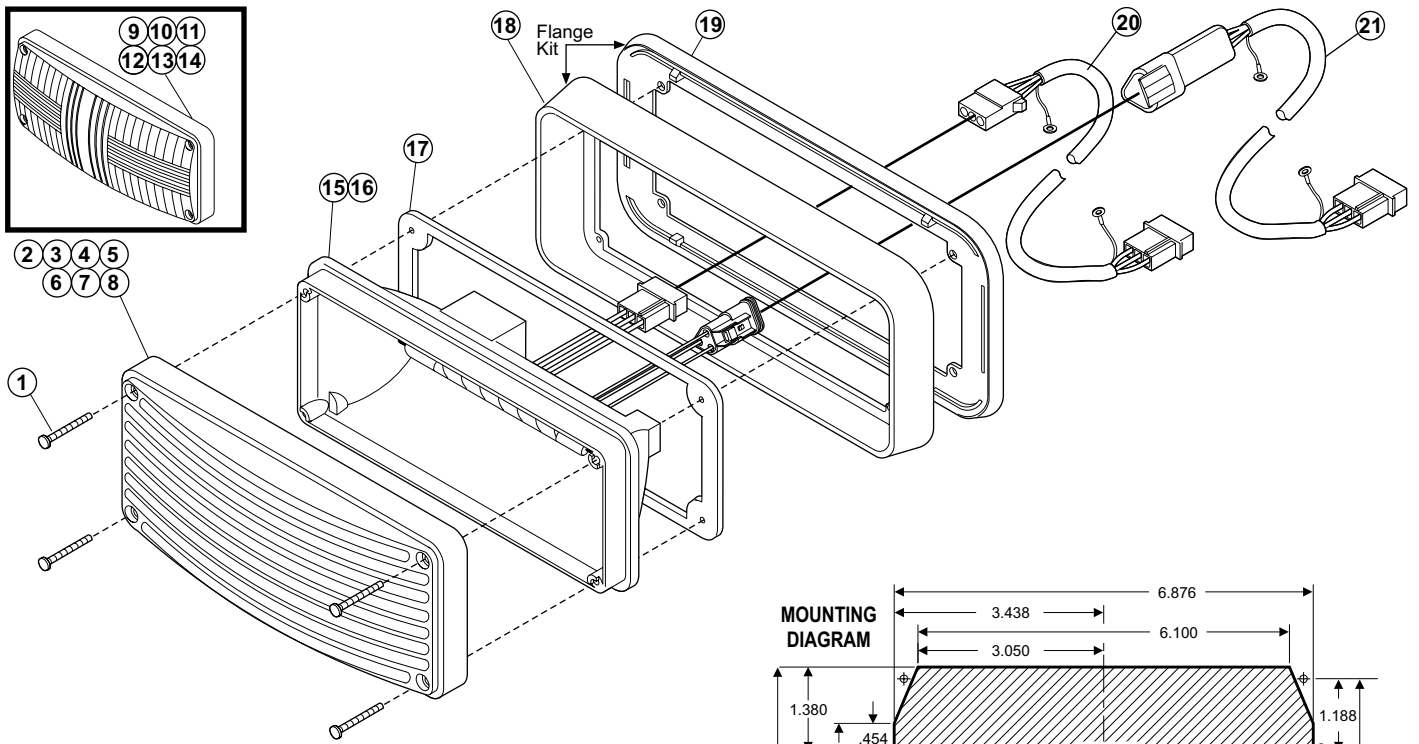

Installation Instructions . . .

1. Using the measurements in the mounting diagram mark off all of the mounting holes you must cut or drill.

NOTE: The mounting diagram is not to scale. Use for reference only.

WARNING! This installation will require drilling. It is absolutely necessary to make sure that nothing will be damaged in the process. If damage is possible, select another mounting location.

2. Drill or cut all the mounting and access holes to the sizes noted in the mounting diagram.

3. Route the wires to your power source.

IMPORTANT: All customer supplied wires that connect to the positive terminal of the battery, must be sized to supply at least 125% of the maximum operating current, and fused at the battery to carry that load.

4. Attach the light housing securely to the vehicle using the 4Phillips sheet metal screws supplied.

5. Connect the wires to your power source.

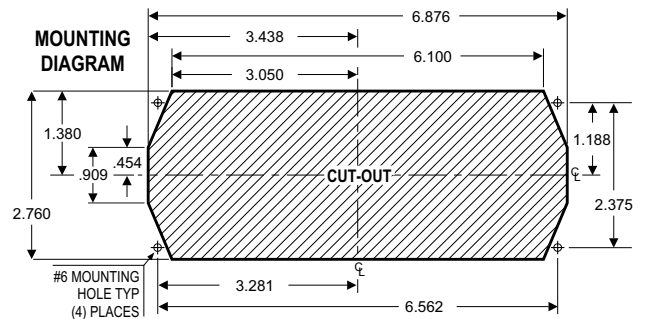

QTY.	ITEM	PART NUMBER	DESCRIPTION
*	*	01-0682895-()	MODEL 73 LINEAR STROBE ASSEMBLY
4	1	15-061416-240	#6 X 1 1/2" PHIL PAN HD SMS
A/R	2	68-1183137-1S	LENS / 73 LINEAR - AMBER W/ SEAL
A/R	3	68-1183137-2S	LENS / 73 LINEAR - BLUE W/ SEAL
A/R	4	68-1183137-3S	LENS / 73 LINEAR - CLEAR W/ SEAL
A/R	5	68-1183137-4S	LENS / 73 LINEAR - GREEN W/ SEAL
A/R	6	68-1183137-5S	LENS / 73 LINEAR - RED W/ SEAL
A/R	7	68-1183137E5S	LENS / 73 LIN KKKE-SPEC RED W/ SEAL
A/R	8	02-0362953-()	LENS / 73 LIN SPLIT W/ SEAL
A/R	9	68-1183520-1S	LENS, AMBER W/ SEAL
A/R	10	68-1183520-2S	LENS, BLUE W/ SEAL
A/R	11	68-1183520-3S	LENS, CLEAR W/ SEAL
A/R	12	68-1183520-4S	LENS, GREEN W/ SEAL
A/R	13	68-1183520-5S	LENS, RED W/ SEAL
A/R	14	02-0383524-()	LENS, SPLIT W/ SEAL
A/R	15	02-0362641-00	73 LINEAR REFLECTOR / AMP CONNECTOR
A/R	16	02-0362641-01	73 LINEAR REFLECTOR / DEUTSCH CONNECTOR
1	17	38-0262823-00	GASKET
A/R	18	11-783141-001	FLANGE WITHOUT SEAL
A/R	19	38-0461354-00	FLANGE GASKET
A/R	20	01-0440624-15	CABLE ASSEMBLY WITH KIT
A/R	21	01-0442199-15	KIT / CABLE ASSEMBLY / WATERPROOF
-	-	01-0462920-00	MODEL 73 SERIES FLANGE KIT / WITHOUT SEAL

The outer surfaces of this product may be cleaned with mild soap and water. Use of any other chemicals may void product warranty. Do not use a pressure washer.