

ROUTE 145, WINTHROP ROAD
CHESTER, CONNECTICUT 06412-0684
TELEPHONE: (860) 526-9504
FAX: (860) 526-4078

Connections...

1. Locate the LED wire that carries the switched signal.
2. Connect the WHITE/RED wire to the "source"-side of this wire.
3. Connect the RED wire to the "LED"-side of this wire.
4. Connect the BLACK wire to chassis ground.

Specifications

V In 10-16 VDC
I Out..... 2.5 Amps (Max.)
V Out Drop 0.8 VDC
Frequency 10 Hz
Pulse Envelope 650mS

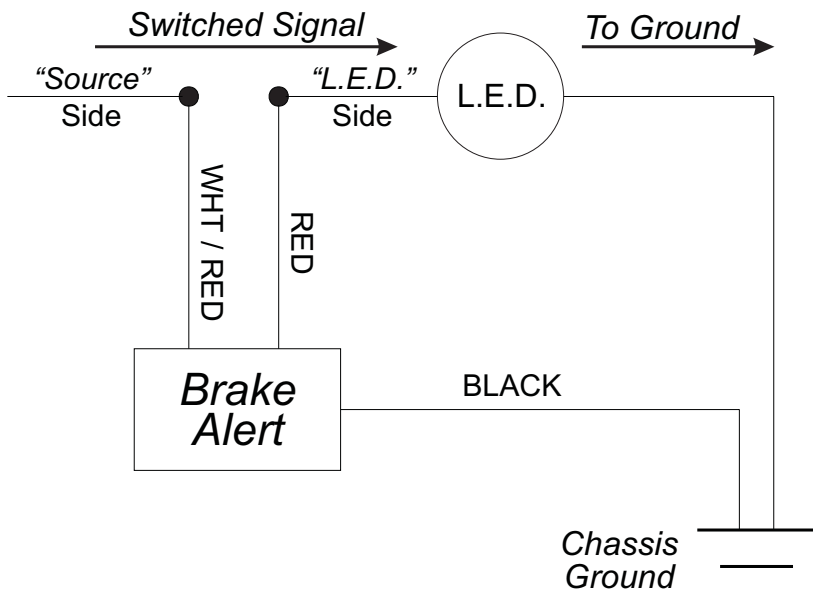

©1998 Whelen Engineering Company Inc.
Form No.13383 (102298)

ROUTE 145, WINTHROP ROAD
CHESTER, CONNECTICUT 06412-0684
TELEPHONE: (860) 526-9504
FAX: (860) 526-4078

Connections...

1. Locate the LED wire that carries the switched signal.
2. Connect the WHITE/RED wire to the "source"-side of this wire.
3. Connect the RED wire to the "LED"-side of this wire.
4. Connect the BLACK wire to chassis ground.

Specifications

V In 10-16 VDC
I Out..... 2.5 Amps (Max.)
V Out Drop 0.8 VDC
Frequency 10 Hz
Pulse Envelope 650mS

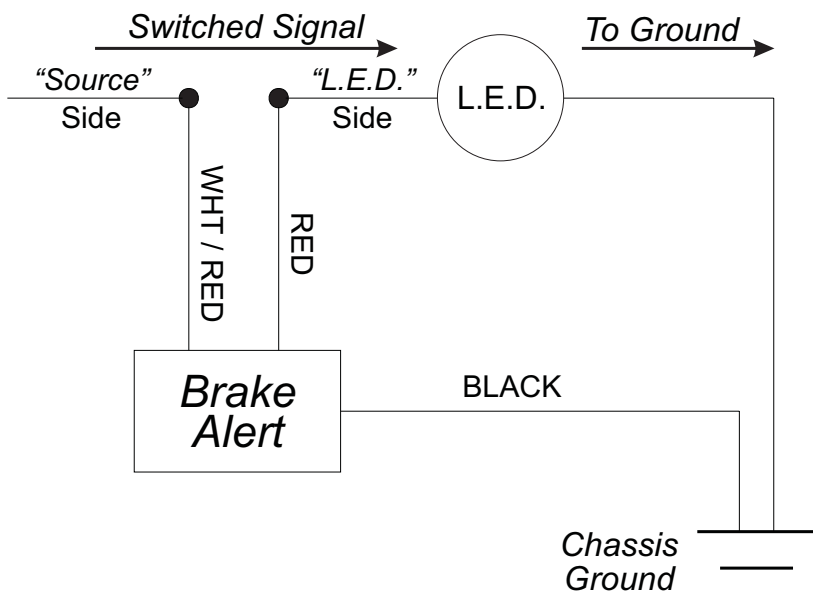

©1998 Whelen Engineering Company Inc.
Form No.13383 (102298)