

WHELEN[®]

ENGINEERING COMPANY INC.

51 Winthrop Road
Chester, Connecticut 06412-0684
Phone: (860) 526-9504
Fax: (860) 526-4078
Internet: www.whelen.com
Sales e-mail: autosale@whelen.com
Canadian Sales e-mail: autocan@whelen.com
Customer Service e-mail: custserv@whelen.com

Installation Guide: Centurion™ Lightbar Option Kit Model KDRF (Rear Flashers)

Safety First

This document provides all the necessary information to allow your Whelen product to be properly and safely installed. Before beginning the installation and/or operation of your new product, the installation technician and operator must read this manual completely. Important information is contained herein that could prevent serious injury or damage.

- Proper installation of this product requires the installer to have a good understanding of automotive electronics, systems and procedures.
- If mounting this product requires drilling holes, the installer **MUST** be sure that no vehicle components or other vital parts could be damaged by the drilling process. Check both sides of the mounting surface before drilling begins. Also de-burr any holes and remove any metal shards or remnants. Install grommets into all wire passage holes.
- If this manual states that this product may be mounted with suction cups, magnets, tape or Velcro®, clean the mounting surface with a 50/50 mix of isopropyl alcohol and water and dry thoroughly.
- Do not install this product or route any wires in the deployment area of your air bag. Equipment mounted or located in the air bag deployment area will damage or reduce the effectiveness of the air bag, or become a projectile that could cause serious personal injury or death. Refer to your vehicle owner's manual for the air bag deployment area. The User/Installer assumes full responsibility to determine proper mounting location, based on providing ultimate safety to all passengers inside the vehicle.
- For this product to operate at optimum efficiency, a good electrical connection to chassis ground must be made. The recommended procedure requires the product ground wire to be connected directly to the **NEGATIVE (-)** battery post.
- If this product uses a remote device to activate or control this product, make sure that this control is located in an area that allows both the vehicle and the control to be operated safely in any driving condition.
- Do not attempt to activate or control this device in a hazardous driving situation.
- This product contains either strobe light(s), halogen light(s), high-intensity LEDs or a combination of these lights. Do not stare directly into these lights. Momentary blindness and/or eye damage could result.
- Use only soap and water to clean the outer lens. Use of other chemicals could result in premature lens cracking (crazing) and discoloration. Lenses in this condition have significantly reduced effectiveness and should be replaced immediately. Inspect and operate this product regularly to confirm its proper operation and mounting condition. Do not use a pressure washer to clean this product.
- It is recommended that these instructions be stored in a safe place and referred to when performing maintenance and/or reinstallation of this product.
- **FAILURE TO FOLLOW THESE SAFETY PRECAUTIONS AND INSTRUCTIONS COULD RESULT IN DAMAGE TO THE PRODUCT OR VEHICLE AND/OR SERIOUS INJURY TO YOU AND YOUR PASSENGERS!**

For warranty information regarding this product, visit www.whelen.com/warranty

Installation:

1. Remove the two Torx head screws that secure the end cap to the base and slide the lens sections and dividers off the end of the base so you may gain access to the lightbar base (Fig. 1 & 2). Be sure to note the order in which the lenses were installed on the lightbar.
2. Place the rear flasher filter assembly on the lightbar base (Fig. 3 & 4). Be sure to insert the lip running the length of the light assembly, into the channel running the length of the lightbar base (Fig. 3). Secure the assembly to the channel in the lightbar base using two of the 3/8" hex head screws provided. Repeat this step for the other side of the lightbar.
3. Measure the lightbar base and find the center point of the lightbar as shown in figure 4 and mark it with a pencil or marker.
4. Using this center mark, determine the proper mounting location for the electronic flasher. Find the double sided tape supplied and attach the tape to the bottom of the flasher then attach the flasher to the lightbar base. **NOTE:** Make sure the area you apply the tape to is clean. Use isopropyl alcohol as a cleaner if necessary.

Fig. 1

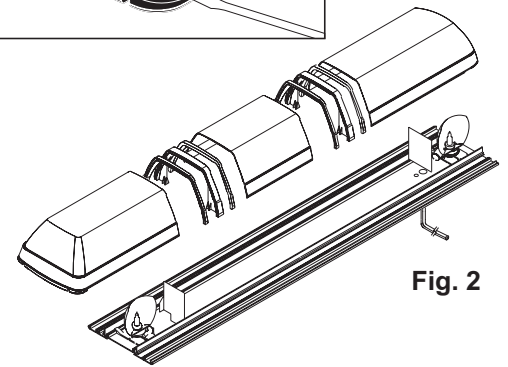
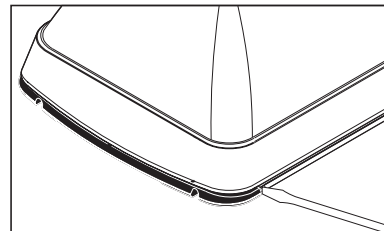
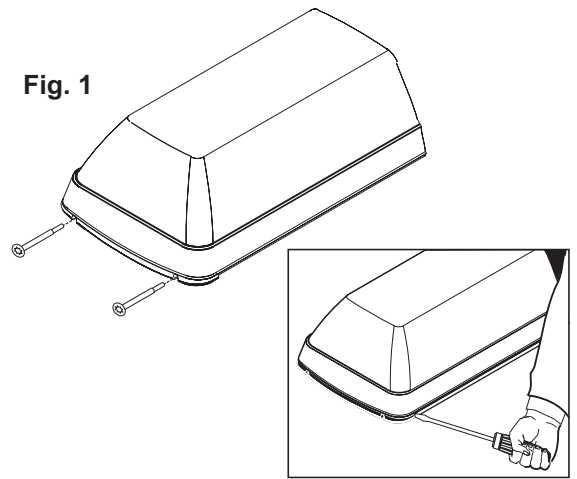
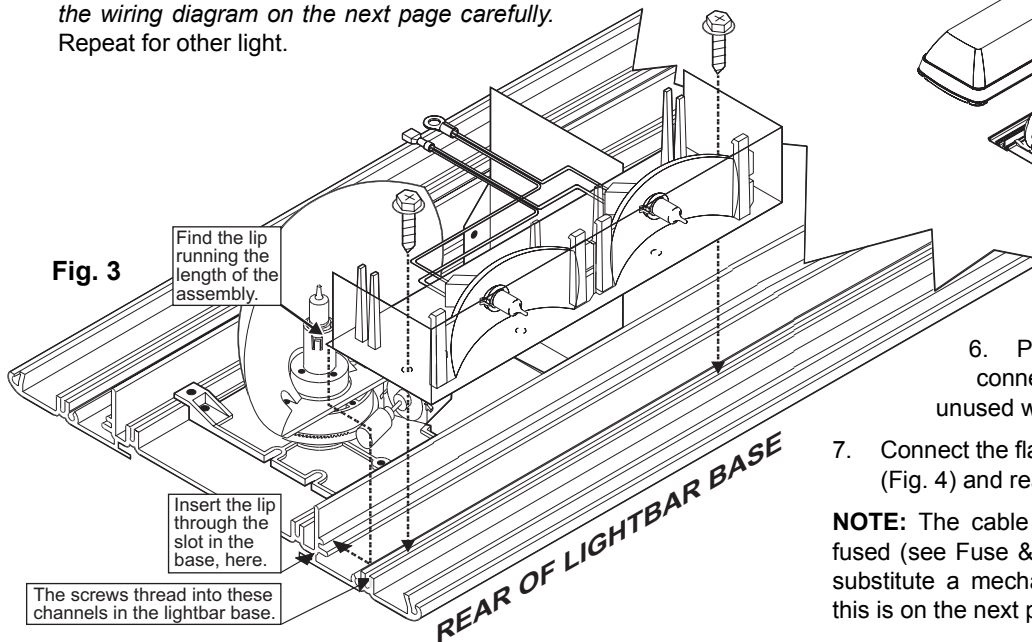

Fig. 2

Wiring:

1. Secure the ground lug for the rear flasher filter assemblies to the channel in the lightbar base using the 1/4" hex head screws provided (Fig. 4).
2. Find the 2 WHITE and 1 BROWN faston connectors supplied.
3. Plug one of the WHITE connectors into the connector coming from one of the light assemblies. Repeat for the other light (Fig. 4).
4. Plug the other end of the WHITE connector coming from the DRIVERS SIDE light into the flasher. **NOTE: Be sure to follow the wiring diagram on the next page carefully.** Repeat for other light.

Fig. 3



5. Following the diagram, plug the BROWN connector into the flasher.

6. Plug the other end of the BROWN connector into the BROWN wire (or any unused wire) in your lightbar wiring harness.

7. Connect the flasher ground lug to the lightbar base (Fig. 4) and reassemble the lightbar.

NOTE: The cable coming from the lightbar must be fused (see Fuse & Switch Information). You may also substitute a mechanical flasher if desired. Wiring for this is on the next page.

IMPORTANT! Neatly Dress and Place Wires Under Cable Clamps to Avoid Interference with other Lighting Options.

Connects to BROWN wire (Or any unused wire) In Lightbar Harness. (See Fuse & Switch Information)

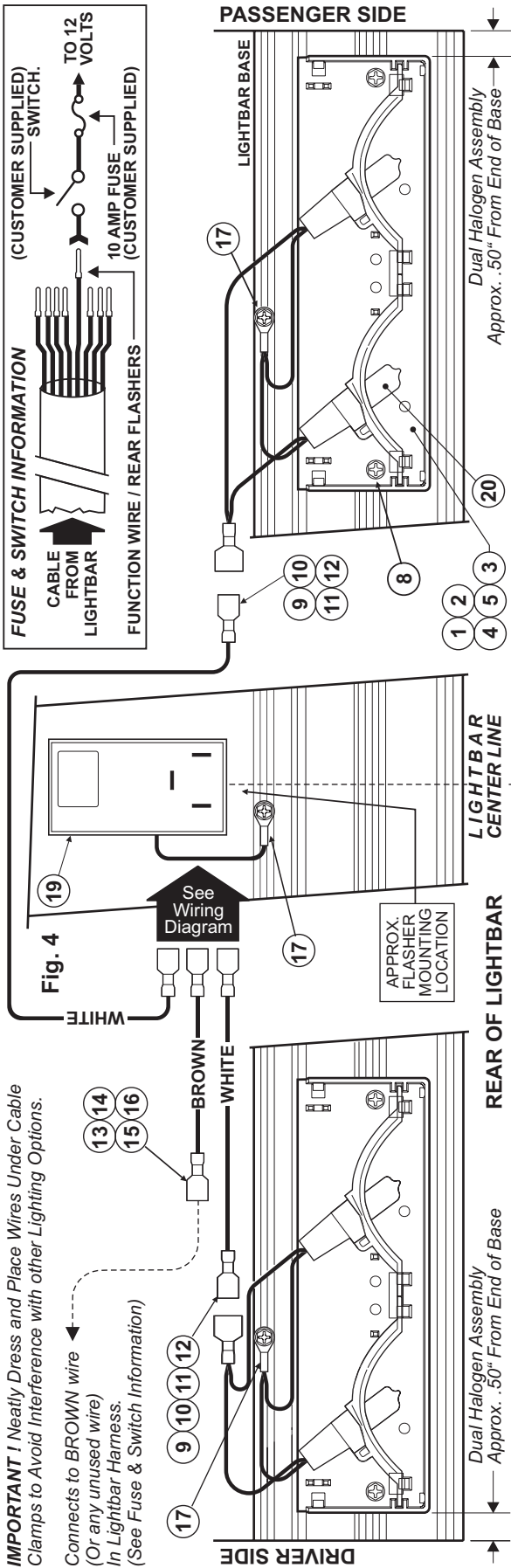

WARNING: DO NOT INSTALL BULBS EXCEEDING 20 WATTS

QTY.	ITEM	QTY.	ITEM	PART NUMBER	DESCRIPTION
4	4	*		02-03629851	ASSY., REAR FLASHERS - CENTURION™ / 22"
-	-	*		02-03629852	ASSY., REAR FLASHERS - CENTURION™ / 48" & 52"
-	-	*		02-03629853	ASSY., REAR FLASHERS - CENTURION™ / 60"
-	-	*		02-03629854	ASSY., REAR FLASHERS - CENTURION™ / 72"
2	2	2	2	02-0362840-A0	ASSY., DUAL HALOGEN FILTER - AMBER
A/R	A/R	A/R	A/R	02-0362840-B0	ASSY., DUAL HALOGEN FILTER - BLUE
A/R	A/R	A/R	A/R	02-0362840-C0	ASSY., DUAL HALOGEN FILTER - CLEAR
A/R	A/R	A/R	A/R	02-0362840-G0	ASSY., DUAL HALOGEN FILTER - GREEN
A/R	A/R	A/R	A/R	02-0362840-R0	ASSY., DUAL HALOGEN FILTER - RED
REF	REF	REF	REF	29-2116380-00	FLASHER, #537 ACME AUTO
REF	REF	REF	REF	26-0115037-17	CABLE CLAMP, 1 1/8"
4	4	4	4	15-081916-066	SCREW, #8 x 3/8" PHEXWASHHD SS TYPE "B"
-	-	2	9	67-1F91899090	WIRE, WHITE 9" W/FASTONS - FLASHER OUTPUT
-	-	2	10	67-1F91899230	WIRE, WHITE 23" W/FASTONS - FLASHER OUTPUT
-	-	2	11	67-1F91899270	WIRE, WHITE 27" W/FASTONS - FLASHER OUTPUT
2	-	-	12	67-1F91899330	WIRE, WHITE 33" W/FASTONS - FLASHER OUTPUT
-	-	1	13	67-1A41811090	WIRE, BROWN 9" W/FASTONS - FLASHER INPUT
-	-	1	14	67-1A41811210	WIRE, BROWN 21" W/FASTONS - FLASHER INPUT
-	-	1	15	67-1A41811250	WIRE, BROWN 25" W/FASTONS - FLASHER INPUT
1	-	-	16	67-1A41811310	WIRE, BROWN 31" W/FASTONS - FLASHER INPUT
3	3	3	17	15-081916-046	SCREW, #8 x 1/4" PHEXWASHHD SS TYPE "B"
1	1	1	18	66-0421074-00	TAPE, MOUNTING
1	1	1	19	01-0246133-00	ASSY., ELECTRONIC FLASHER
-	-	-	20	01-0441987-04 C	KIT, H20SN12 REPLACEMENT

PART NUMBER KEY FILTER COLOR A = AMBER B = BLUE C = CLEAR G = GREEN R = RED
LENGTH 1 = 22" 2 = 48" - 52" 3 = 60" 4 = 72"

← PASSENGER FILTER COLOR ← DRIVER FILTER COLOR ← LENGTH



MECHANICAL FLASHER (OPTIONAL)

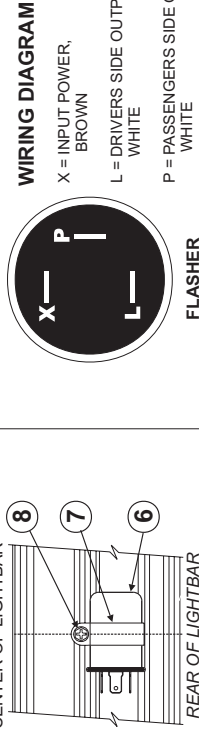

NOTE: When reassembling the lightbar, before inserting the gaskets into the plastic dividers apply some liquid dish detergent to the sides of the rubber gaskets to help them slide in easier.

