

WHELEN[®]

ENGINEERING COMPANY INC.

51 Winthrop Road
Chester, Connecticut 06412-0684
Phone: (860) 526-9504
Fax: (860) 526-4078
Internet: www.whelen.com
Sales e-mail: autosale@whelen.com
Canadian Sales e-mail: autocan@whelen.com
Customer Service e-mail: custserv@whelen.com

Installation Guide: Centurion™ Lightbar Option Kit Model KDTD2 (Take-down Lights)

Safety First

This document provides all the necessary information to allow your Whelen product to be properly and safely installed. Before beginning the installation and/or operation of your new product, the installation technician and operator must read this manual completely. Important information is contained herein that could prevent serious injury or damage.

- Proper installation of this product requires the installer to have a good understanding of automotive electronics, systems and procedures.
- If mounting this product requires drilling holes, the installer **MUST** be sure that no vehicle components or other vital parts could be damaged by the drilling process. Check both sides of the mounting surface before drilling begins. Also de-burr any holes and remove any metal shards or remnants. Install grommets into all wire passage holes.
- If this manual states that this product may be mounted with suction cups, magnets, tape or Velcro®, clean the mounting surface with a 50/50 mix of isopropyl alcohol and water and dry thoroughly.
- Do not install this product or route any wires in the deployment area of your air bag. Equipment mounted or located in the air bag deployment area will damage or reduce the effectiveness of the air bag, or become a projectile that could cause serious personal injury or death. Refer to your vehicle owner's manual for the air bag deployment area. The User/Installer assumes full responsibility to determine proper mounting location, based on providing ultimate safety to all passengers inside the vehicle.
- For this product to operate at optimum efficiency, a good electrical connection to chassis ground must be made. The recommended procedure requires the product ground wire to be connected directly to the **NEGATIVE (-)** battery post.
- If this product uses a remote device to activate or control this product, make sure that this control is located in an area that allows both the vehicle and the control to be operated safely in any driving condition.
- Do not attempt to activate or control this device in a hazardous driving situation.
- This product contains either strobe light(s), halogen light(s), high-intensity LEDs or a combination of these lights. Do not stare directly into these lights. Momentary blindness and/or eye damage could result.
- Use only soap and water to clean the outer lens. Use of other chemicals could result in premature lens cracking (crazing) and discoloration. Lenses in this condition have significantly reduced effectiveness and should be replaced immediately. Inspect and operate this product regularly to confirm its proper operation and mounting condition. Do not use a pressure washer to clean this product.
- It is recommended that these instructions be stored in a safe place and referred to when performing maintenance and/or reinstallation of this product.
- **FAILURE TO FOLLOW THESE SAFETY PRECAUTIONS AND INSTRUCTIONS COULD RESULT IN DAMAGE TO THE PRODUCT OR VEHICLE AND/OR SERIOUS INJURY TO YOU AND YOUR PASSENGERS!**

For warranty information regarding this product, visit www.whelen.com/warranty

Installation:

1. Remove the two Torx head screws that secure the end cap to the base and slide the lens section and dividers off the end of the base so you may gain access to the lightbar base (fig. 1). Be sure to note the order in which the lenses were installed on the lightbar.

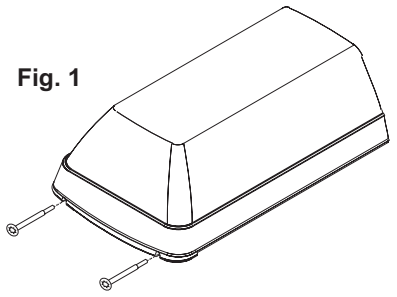

IMPORTANT NOTE: You will notice that the lenses are seated very tightly into the lens divider gaskets to prevent leaks. You will need to insert a screwdriver at each corner (between the black endcap and aluminum base) and gently pry the lens out to break it free from the dividers. Pry each side out just a little at a time, alternating from one side to the other until the lens slides out easily. Before reassembling, apply a very small amount of liquid dish detergent to the sides of the rubber gaskets to help them slide in easier and obtain a better seal.

2. Place the take-down light assembly onto the lightbar base going by the measurements in figure 4. Be sure to insert the lip on the end of the take-down assembly, into the slot in the base as shown (Fig. 2). Secure the assembly to the channel in the lightbar base, using two of the 3/8" hex head screws provided. Repeat this step for the other side.

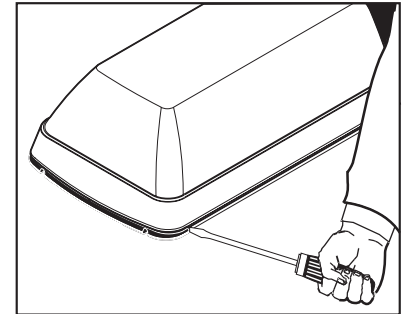

Wiring:

1. Secure the ground lug for the take-down assemblies to the channel in the lightbar base using the 1/4" hex head screws provided. (Fig. 2)
2. Connect the input harness provided, to the faston connectors of the take-down assemblies. Run the input harness along the lightbar base as indicated and connect it to the GREY wire (or any unused wire) in the lightbar wiring harness.
3. Neatly dress and place any loose wires under the cable clamps to avoid interference with any moving parts then replace and secure all domes.

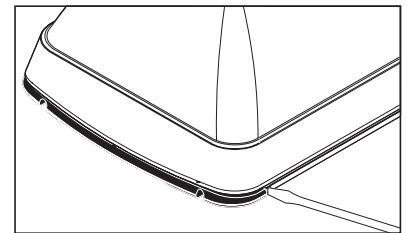

NOTE: The cable coming from the lightbar must be fused (see diagram below).

Fig. 2

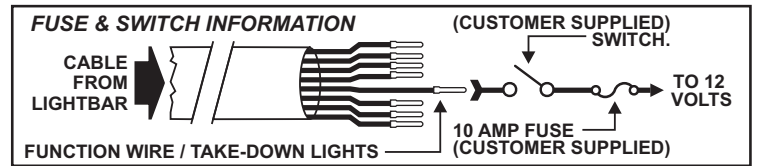
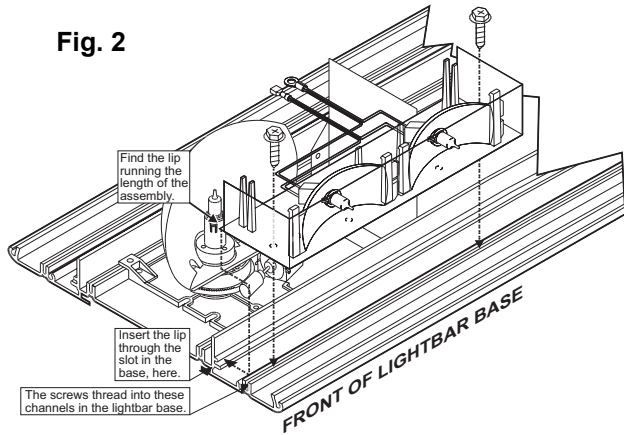

QTY.	QTY.	ITEM	PART NUMBER	DESCRIPTION
*	*		02-0362986-C1	KIT, TAKE-DOWN LIGHTS - CENTURION™ (48" - 52" & 22")
*	*		02-0362986-C3	KIT, TAKE-DOWN LIGHTS - CENTURION™ (72" & 60")
2	2	1	02-0362840-C0	ASS'Y., DUAL HALOGEN FILTER - CLEAR
4	4	2	15-081916-066	SCREW, #8 x 3/8" PHEXWASHHD SS TYPE "B"
2	2	3	15-081916-046	SCREW, #8 x 1/4" PHEXWASHHD SS TYPE "B"
-	1	4	46-0762978-00	HARNESS, TAKE-DOWN LIGHTS - CENTURION (48" & 52")
1	-	6	46-0762978-02	HARNESS, TAKE-DOWN LIGHTS - CENTURION (72")
-	-	7	01-0441987-04C	KIT, H20SN12 REPLACEMENT

WARNING: DO NOT INSTALL BULBS EXCEEDING 20 WATTS.

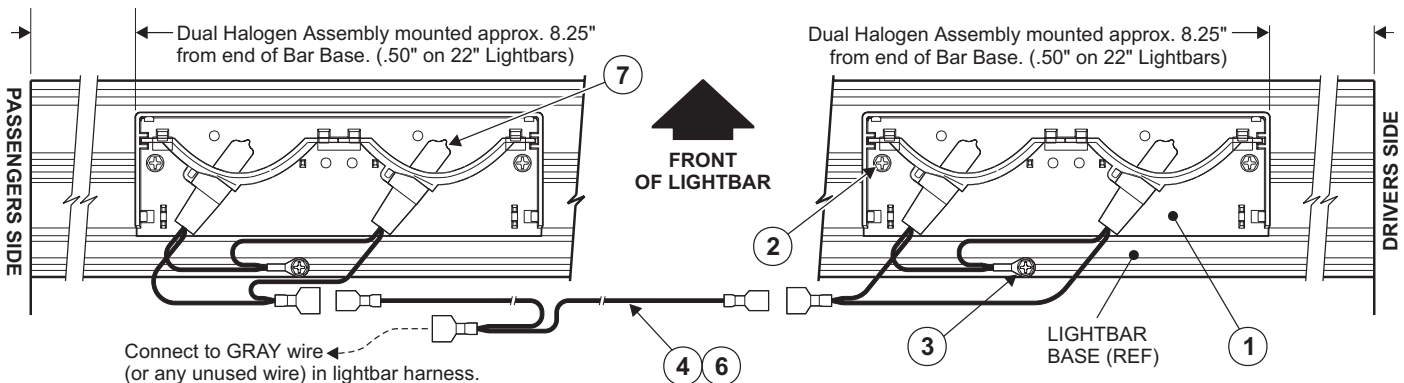

IMPORTANT ! Neatly dress and place wires under cable clamps to avoid interference with other lighting options.

The outer surfaces of this product may be cleaned with mild soap and water. Use of any other chemicals may void product warranty. Do not use a pressure washer.