

SIPS 400/800

IN-PLANT WARNING SYSTEM

Product Manual

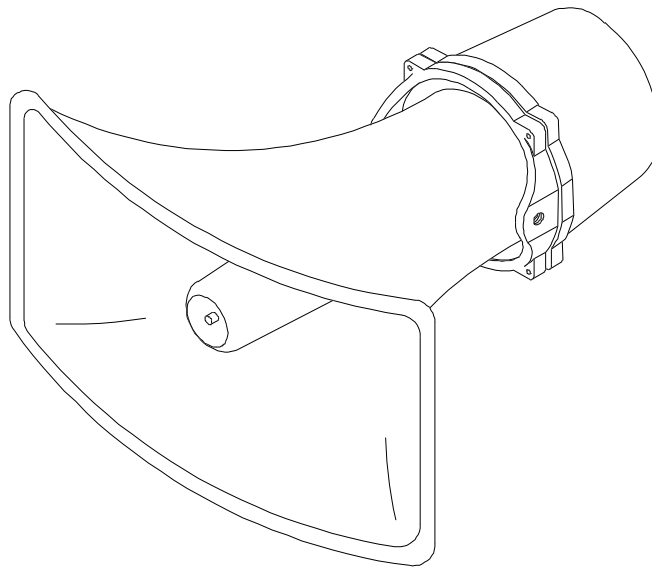

PIONEERS IN WARNING SIGNALS
WHELEN®
ENGINEERING COMPANY, INC
Route 145, Winthrop Rd., Chester, CT 06412-0684
Tel.: (800) 63SIREN • Fax: (860) 526-4784

The purpose of this manual is to provide the user with a general description of the theory, operation, installation set-up and maintenance of an SIPS-400 or SIPS-800, In-Plant Warning System.

This manual contains information proprietary to Whelen Engineering Company, Inc. Any reproduction of this manual is expressly prohibited except as Whelen Engineering Company, Inc. may otherwise agree to in writing.

Whelen Engineering Company, Inc. reserves the right to revise and improve its product as it sees fit.

Table of Contents

Section 1	INTRODUCTION	2
1.0	Introduction to the SIPS	2
1.1	Device Level Supervision	2
1.2	Using This Manual.....	2
Section 2	SIPS CONTROLLER DESCRIPTION.....	3
2.0	Controller System Description.....	3
2.1	Physical Description.....	3
2.2	Operational Description	4
2.2.1	System Activation/Control Methods	4
2.2.2	Timing Selection and Duration	4
2.2.3	Audio Characteristics of Warning Signals.....	4
Section 3	SPECIFICATIONS	5
3.0	General Specifications.....	5
Section 4	MODULE DESCRIPTION	6
4.0	SIPS Module Descriptions.....	6
4.1	ESC-864 (Controller).....	6
4.1.1	Local Controls and LED Indicators	6
4.1.2	ESC-864 Controller Circuit Board.....	9
4.1.3	Tone Generator	9
4.1.4	Digital Voice (option)	9
4.1.5	Landline or RF Link Interfaces (options).....	9
4.1.6	DTMF Formats	9
4.1.7	Radio Receiver/Transceiver (option).....	11
4.1.8	Local Microphone Input and Volume Control	11
4.1.9	System Diagnostics	11
4.2	Power Amplifier Operation	11
4.2.1	Speaker Configurations	12
4.3	System Driver Board	13
4.3.1	SIPS Silent Test Operation	13
4.3.2	Power Saving Logic	14
4.3.3	DC Voltage Regulation	14
4.4	Supervision Board Operation.....	15
4.4.1	Speaker Channels.....	15
4.4.2	Strobe Channels	16
4.4.3	Strobe Control Jumper Settings	16
4.5	Battery Charger Operation	16
4.6	Batteries.....	17
Section 5	INSTALLATION	18
5.0	Installation Instructions.....	18
5.1	Site Selection	18
5.2	Receiving/Unpacking the SIPS.....	19
5.3	Installation of the SIPS Cabinet.....	19
5.3a	Installation of the "Type C" Cabinet.....	20
5.4	Conduit Openings for the SIPS Cabinet.....	21
5.5	AC Wiring	22
5.6	Speaker Wiring	23

5.7	End-of-Line Resistor	24
Section 6	BATTERIES.....	25
6.0	Battery Installation	25
6.1	Battery Connections	25
Section 7	CONTROLLER PROGRAMMING.....	26
7.0	ESC-864 Controller Programming	26
7.1	User E ² PROM Programming	26
7.2	ESC-864 Encoding/Decoding Parameters.....	26
7.3	Warning Tone Timing Programming	26
7.4	DIP Switch Programming	27
Section 8	SPEAKERNODE.....	29
8.0	SpeakerNode Installation.....	29
8.1	SpeakerNode Power Settings	30
8.2	SpeakerNode Switch Settings	33
Section 9	STROBENODE	34
9.0	StrobeNode Installation	34
9.1	StrobeNode Switch Settings.....	35
Section 10	TESTING & TROUBLESHOOTING.....	36
10.0	System Testing & Troubleshooting.....	36
10.1	Initial Operational Checkout	36
10.2	System-Level Faults and Troubleshooting Procedures.....	36
Section 11	REPLACEMENT	40
11.0	Replacements Procedures	40
11.1	ESC-864 Controller Replacement.....	40
11.2	System and Four Output Driver Board Replacement	40
11.3	Power Amplifier Replacement.....	40
11.4	Battery Charger Replacement.....	40
Section 12	INSPECTION	41
12.0	Routine Inspections.....	41

Appendix

Siren Command Definitions
 Siren Command Response Structure
 Remote Siren Response Definitions
 SIPS SpeakerNode Cable Selection
 SIPS StrobeNode Cable Selection
 Product Description - SpeakerNode
 Product Description - StrobeNode

Section 1 INTRODUCTION

1.0 Introduction to the SIPS

Information on the operation, installation, and maintenance of the Whelen Engineering Company's In-Plant Warning System (SIPS) is provided in this technical manual. The SIPS-400 and the SIPS-800 are essentially the same. The SIPS-400 has a single 400 watt amplifier, while the SIPS-800 has two amplifiers. This means that the SIPS-800 can drive 800 watts of audio power versus 400 watts for the SIPS-400. The SIPS-800 also has more battery capacity than the SIPS-400. In the majority of cases throughout this manual, the SIPS-400 and SIPS-800 models will be referred to as a **SIPS**.

The SIPS is a complex **system**, capable of generating six standard warning signals and Public Address (PA). The SIPS can operate with various combinations of speakers and strobes, and various combinations of line level and device level **supervision**. The SIPS may be linked to a central control point or points via radio frequency (RF) or landline (telephone circuit, dry contact or dual tone multifrequency via twisted pair), permitting multiplexed control and supervision.

A typical In-Plant Warning System consists of a Control Cabinet, with an ESC-864 Controller, 1 or 2 Power Amplifiers, a System Driver Board, a Supervision Board, a Battery Charger and Batteries. In addition, a system may include some number of SpeakerNodes and StrobeNodes, as well as some number of speakers and strobes.

SpeakerNodes and StrobeNodes are required for device level supervision. Since the characteristics of a speaker or strobe must be pre-programmed into a node to achieve supervision, only certain speakers and strobes may be used in a device level supervision application.

1.1 Line Level Supervision

The SIPS provides easy to use line level supervision, for speakers and strobes, incorporating the End-of-Line resistor approach, common to the fire alarm industry. The supervision circuitry continuously monitors the two wire audio path to the speakers or the two wire control path to the strobes. Any short or open condition is instantly reported to a Central Station and easy-to-read LED indicators are set at the Control Cabinet. A maintenance technician simply identifies the wiring run with the problem and corrects it.

1.2 Device Level Supervision

A unique feature of the SIPS is the device level supervision capability. Device level supervision consists of continuous monitoring of the speakers and strobes via a relay closure link between the supervision board and the SpeakerNodes and StrobeNodes. A failure in a warning device, such as a speaker or a strobe, will be detected by the SpeakerNode or StrobeNode, respectively. This information is passed to the SIPS Control Cabinet, which in turn sets LED indicators and sends the fault condition on to a central control point. A maintenance technician identifies the wiring run with the failure, and locates the faulty device by finding the node for failure indicator. This greatly simplifies locating and repairing a faulty warning device, even if the failure is a cut wire or a bad speaker driver.

1.3 Using This Manual

This manual is divided into a number of sections. Much of the discussion relates to generic Whelen Engineering Company, Inc. siren operation, which is consistent with other Whelen products, like the WPS-2800 Series. Since every SIPS system has a control cabinet, it is covered in the most detail. Optional system components, such as; speakers, strobes, SpeakerNodes or StrobeNodes are discussed in individual sections or in separate Product Description sheets.

Section 2 SIPS CONTROLLER DESCRIPTION

2.0 Controller System Description

This section provides a general description of the SIPS siren controller, including a physical description and a functional description of the system. The functional description includes system activation methods, timing selection, signal and audio characteristics, and power requirements.

2.1 Physical Description

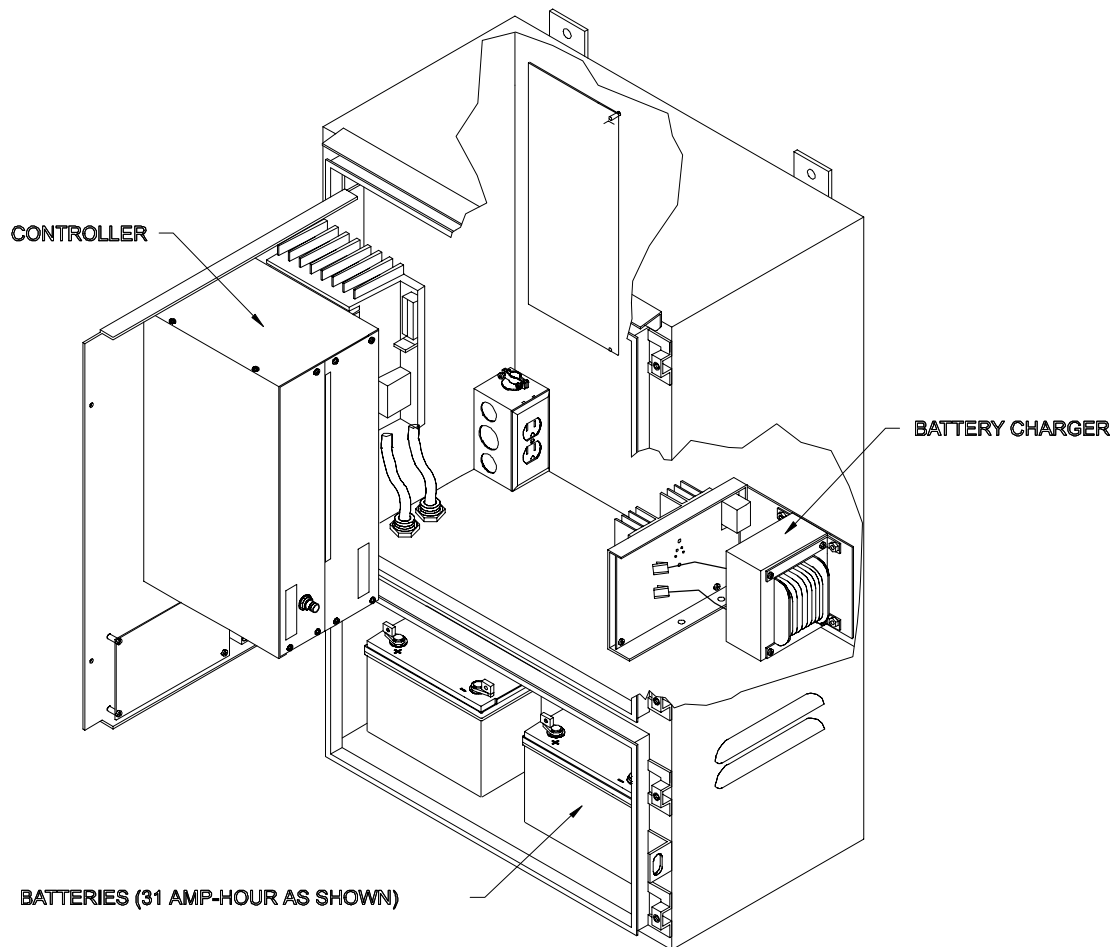

The SIPS is housed in an aluminum cabinet having two compartments. Each compartment has a raised, rolled lip along its perimeter, and each compartment has a full gasket door. The lower compartment houses two Gel type batteries. The upper compartment contains the electronic modules, such as the ESC-864 Controller and Tone Generator, the Power Amplifiers, the Battery Charger, the System Driver Board and a Supervision Board.

The modules are described in detail in Section 4.

2.2 Operational Description

As previously mentioned, the SIPS is a self-contained, microprocessor-controlled warning system capable of generating six standard siren warning signals, public address broadcast, and strobe light signaling. The standard warning signals--WAIL, ALERT, ATTACK, AIR HORN, HI/LO, AND WHOOP--are described in detail in Section 4.1.1.

The SIPS is powered by a 115 VAC, 2 Amp service. A battery charger maintains two, 12 VDC, Gel type batteries, wired in series, at an optimum charge level. The SIPS actually operates from the 24 volts provided by the batteries. Fully charged batteries will run a SIPS, at full audio output levels, for at least thirty minutes.

2.2.1 System Activation/Control Methods

The SIPS may be controlled through local or remote means, as follows:

Local Control. Pushbuttons on the front panel, of the ESC-864, provide immediate activation of warning tones, public address and SI TEST®. A microphone, for PA announcements, may be plugged into the microphone jack on the controller front panel. Detailed descriptions of each control on the front panel of the ESC-864 is provided in Section 4.1.1.

Remote Control. Remote control of a SIPS may be accomplished by landline or radio transmission. The standard communication protocol is a ten digit DTMF (dual tone multi frequency) format. For landline control, an encoder is required at a central control point. For radio transmission, an encoder, connected to a transceiver, is used at the central control point. In either case, an optional interface must be selected for the SIPS.

2.2.2 Timing Selection and Duration

The timing of each activation, local or remote, is controlled by the ESC-864 controller. The ESC-864 is capable of timing any remote station activation for a duration of one second to ten minutes. The factory-standard for activation time duration is **three minutes**. Any activation in progress may be canceled by pressing the CLR (clear) pushbutton on the ESC-864 front panel or by sending a CLEAR or CANCEL command.

2.2.3 Audio Characteristics of Warning Signals

The audio characteristics (frequency and sweep rate) for the SIPS warning signals/tones are provided in Section 4.1.1. Overall output sound pressure levels are dependent on the types of speakers and speaker layouts. All SIPS warning signals are United States Standard Warning Signals.

Section 3 SPECIFICATIONS

3.0 General Specifications

The table below refers to general specifications for a SIPS control cabinet. Specifications for SpeakerNodes and StrobeNodes are included in the Product Descriptions in the Appendix. Specifications for speakers and strobe lights are available upon request.

SIPS Specifications

PHYSICAL DIMENSIONS	Height: 32.5 inches (not including mounting flanges)
	Width: 20.0 inches
	Depth: 12.0 inches
WEIGHT	SIPS-400: 120 lb.
	SIPS-800: 160 lb.
ELECTRICAL REQUIREMENTS	AC Input: 120/240 VAC, 60Hz, 2 Amps
	Battery Charger: 28 VDC nominal, 5.0 Amp
	Batteries (SIPS-400): two 12VDC, >30AH (SIPS-800): two 12VDC, >60AH
ENVIRONMENTAL REQUIREMENTS	Operating Temperature: -35 to 60°C
	Storage Temperature: -65 to 125°C

Section 4 MODULE DESCRIPTION

4.0 SIPS Module Descriptions

This section provides an overview of the individual electronic modules in a SIPS.

- ESC-864 (Controller)
- Power Amplifier(s)
- System Driver Board
- Supervision Board
- Battery Charger
- Batteries

4.1 ESC-864 (Controller)

The ESC-864 Controller is the microprocessor-based core of the SIPS. The ESC-864 houses the following:

local pushbuttons and LED indicators,
the ESC-864 controller circuit board,
the tone generator,

as options:

digital voice,
landline or RF link interfaces,
radio receiver/transceiver.

4.1.1 Local Controls and LED Indicators

Local control is available at the front panel of the ESC-864, as described below.

Local Control and Indicator Functions

Control or Indicator	Control or Indicator Function
CLR	Stops warning tones prior to completion of programmed time. Some tones "ramp down" prior to turning off.
WAIL	Siren tone. Initiates a slow rise, high-pitched tone for four seconds, followed by a softer, winding-down for one second. This sound pattern continues for as long as the timing duration is set.
ATK	Siren tone for National Attack. Initiates a faster rise, high-pitched tone for one second, followed by a winding down tone for one second. This sound pattern continues for as long as the timing duration is set.
ALRT	Siren tone for Alert. Initiates a quick rise then steady tone for as long as the timing duration is set.
AIR HORN	Siren tone. Initiates a pulsing buzzing tone, which blasts in intervals of 1.6 seconds for as long as the timing duration is set.
HI-LO	Siren tone. Initiates a highly pitched tone with a "Dee" sound for 0.8 seconds, followed by a lower-pitched "Doo" sound for 0.8 seconds. This sound pattern continues for as long as the timing duration is set.
WHP	Siren tone for Whoop. Initiates a high-pitched, repetitive rise-only sound for three seconds, then stops. This sound pattern continues for as long as the timing duration is set.

Control or Indicator	Control or Indicator Function
WAIL 5 SEC	Siren tone. Initiates a high pitched tone, followed by a softer, winding cry. Actual on time is more than 5 seconds. NOTE: The five-second WAIL siren tone is often referred to as the NOON TEST.
CW	CW is not used with an SIPS.
CCW	CCW is not used with an SIPS.
SI TEST®	Initiates the SI TEST® tone and the diagnostic SI TEST® routine.
XMIT TONE	For use with remote station radio transceiver; causes transmission of DTMF tone via RF link for tone modulation adjustment. The transmit tone level is adjusted by the transmit level potentiometer on the ESC 864 front panel.
XMIT	Actuates remote station radio transmitter push-to-talk (PTT) circuit. When tone squelch is used with the transmitter, the XMIT function is used to adjust tone squelch modulation.
DC	DC LED indicates that DC voltage is present during a siren tone or SI TEST® activation.
FULL	Full LED indicates that all remote station speakers are operating during a siren tone or SI TEST® activation.
DIAGNOSTIC OUTPUT	Diagnostic output (25 pin connector) serves as the ESC 864 PC board (controller) input/output port for diagnostic and programming purposes. System diagnostic information and programming is accomplished with the Whelen MDK-864 Diagnostic Keyboard used in servicing or testing the SIPS.
REPROGRAM	This REPROGRAM pushbutton, which is recessed, is for use by technicians trained in the use of the MDK-864 diagnostic keyboard for <i>factory service purposes only</i> . CAUTION: Pressing this button will erase customer-specific programming and return the ESC 864 controller to default settings. Pressing this button will render the siren station unresponsive to customer-specific activation until the unit is reprogrammed.
ROT	ROT (LED) is not used with a SIPS.
PART	PART (partial) LED indicates that at least one speaker driver operated during a warning tone or SI TEST® activation.
AC	AC LED indicates that AC voltage was present during a warning tone or SI TEST® activation.
CLIPPING INDICATOR	The clipping indicator LEDs illuminate when a warning tone is active or when a public address signal of sufficient amplitude is processed by the tone generator.
MIC VOLUME	This knob controls the output volume of local public address announcements. In determining a sufficient volume adjustment for local public address announcements, the clipping indicator LEDs should just begin to blink when the local announcement is produced. This "blinking" indicates the maximum amplification of sound with negligible distortion.
MIC	This microphone jack is used for local public address announcements. Upon insertion of a microphone plug into the jack, the timer set LED may come on for approximately one second. To use the microphone, squeeze the lever on its side completely and verify that the timer set LED illuminates. Use of the local microphone disconnects remote radio audio input from the tone generator's input, eliminating outside interference. Removing the

Control or Indicator	Control or Indicator Function
	microphone from the microphone jack restores the remote radio audio input.
XMIT	The XMIT LED, when illuminated, indicates that the ESC-864 is actuating the SIPS transmitter push-to-talk (PTT) circuit and is transmitting data or a test tone.
PWR	The PWR (power up) LED indicates that all modules in the remote station are powered up and all parts of the system are ready to operate. For systems using AC power operating the SIPS battery charger, this LED is on at all times unless an AC outage occurs, prompting the SIPS to go into a power-saving mode.
DEC	The DEC (decoder active) LED illuminates when the DTMF tone decoder receives and processes incoming DTMF tones. The DEC LED appears to flash when it illuminates. This is a normal condition, as it blinks for every valid DTMF digit that is decoded.
PROG	The PROG (program) LED only illuminates when the MDK-864 Diagnostic Keyboard is used and the program switch on the MDK-864 is in the ON position. When the program LED is illuminated, the siren cannot be activated remotely.
SQ	The SQ (Squelch) LED illuminates when the radio receiver detects that the appropriate carrier frequency is active. For systems that have the optional programmable receive tone squelch tone decoder, the LED only illuminates when the receive frequency, as well as the sub-audible tone squelch frequency tone, is detected.
TIM	The TIM (timer set) LED illuminates whenever the system is activated by either radio link, landline control, or from the front panel for any of the siren functions or public address.
XMIT LEVEL	The XMIT (transmit) LEVEL adjustment potentiometer controls the modulation of the DTMF tones that are transmitted when the remote station status reporting option is used.
RADIO LEVEL	The RADIO LEVEL adjustment potentiometer is used to set the audio level that will be passed on to the tone generator from a radio receiver or landline audio input. NOTE: The transmit level and the radio level adjustment potentiometers are preset at the factory and should not be changed except by qualified personnel.
POWER AMP LEDs	The power amplifier LEDs, located on the front panel to the left of the ESC-864 case face plate, are used for visual inspection and verification regarding the wiring circuit between each power amplifier channel and its respective speaker drivers. One speaker driver is wired to each power amplifier channel by a dedicated pair of wires. Upon activation of a warning or siren tone, a SI TEST® tone, or a public address signal of sufficient level, these LEDs should illuminate, indicating a complete circuit. NOTE: The front panel LEDs assume the SIPS is operating under proper speaker loading capacity. Without sufficient loading, (greater than 60 Watts) the front panel LEDs will not operate effectively.

4.1.2 ESC-864 Controller Circuit Board

The ESC-864 Controller board allows for local activation of warning signals, plus remote control interfacing. It also monitors system status and provides visual status indicators as described in the previous tables. The ESC-864 PC board controls the tone generator. All DTMF processing is performed on the ESC-864 board.

4.1.3 Tone Generator

The tone generator is a separate PC board that is mounted to the ESC-864 board. The tone generator receives its commands from the ESC-864 board. All siren tones and public address audio processing are accomplished within the tone generator. The microphone jack and microphone volume control, as well as a clipping indicator, are also part of the tone generator functionality.

4.1.4 Digital Voice (option)

The optional digital voice module is mounted onto the tone generator in the ESC-864 case. The digital voice module allows the SIPS to store prerecorded, digitized messages for transmission over the public address portion of the system. Prerecorded, digitized 15, 30 and 60-second messages are available.

4.1.5 Landline or RF Link Interfaces (options)

As an option, the SIPS may be remotely controlled either landline or RF link. Either method communicates via a DTMF protocol. Remote control may be one-way or two-way. The one-way option simply controls the SIPS, while the two-way option controls the SIPS and reports SIPS status back to a central control point.

The built-in DTMF capability responds to activation commands and generates status responses. The formats and definitions for **Activation Commands and Status Responses** are described below.

4.1.6 DTMF Formats

ACTIVATION WORDS

Activation Command Format

Area Code	Station Address Code	ID & CMD Set	CMD
3 digits	4 digits	2 digits	1 digit

Activation Command (Definition of above Format)

Function	Description
Area Code	3-digit code which allows up to 1000 area codes per frequency.
Station Address	4-digit code assigned to each warning system within an area code.
ID	1-digit ID code allowing up to 8 activation centers.
CMD Group	1-digit code allowing for 4 command groups.
CMD	1-digit code allowing for 16 commands.

Status Response Format

Area Code	Address Code	Length	Response	Status Bytes	
				Digital	Analog
3 digits	4 digits	1 digit	2 digits	Variable Length	variable length

Status Response (Definition of Format)

Function	Description
Area Code	3-digit code which allows up to 1000 area codes per frequency.
Station Address	4-digit code assigned to each warning system within an area code.
ID	1-digit ID code identifies the type of siren.
Length	Informs base station as to the length of the response word.
Response	2-digit code which reports status of alarm responses, inquiries, and command groups.
Status Bytes	2 to 8-digit code carrying digital/analog status information.

SIPS Status Descriptions

Status Reporting Information (Subject)	Status Designation
Station AC Power	on/off
Station AC Line Voltage	3-digit representation
Station DC Voltage	2-digit representation
Partial Amplifier and Speaker Driver	Operation
Ambient Temperature	3-digit representation
System Power Up Status	on/off
Intrusion Alarm	instant status response for open door condition
Low Battery Condition	low battery status has been reached
Receiver Signal-to-Noise Ratio (S/N)	2-digit activation count

The ESC-864 board reports status information to a central control point in response to the following alarm conditions:

- a change-of-state alarm (user selectable on/off)
- instant response to individual activation (user selectable on/off) or
- response to individual interrogation.
- supervision errors.

In the event of an alarm condition, the ESC-864 board will transmit its status report three times to ensure that the message is received. The first transmission will happen immediately upon change of status, the second transmission fifteen (15) seconds after the first, and the third fifteen (15) seconds after the second transmission. If, after these transmissions, the RF link remains busy, the ESC-864 PC board will terminate transmission. With respect to this latter statement, a squelch detect circuit is included within the ESC-864 board's design. This feature prevents interference with other transmissions on the RF link. The squelch detect circuit will prevent status transmission if the RF channel is busy. The ESC-864 may be configured to operate in the squelch detect mode on the basis of RF carrier squelch or tone-coded squelch.

The ESC-864 board provides service and diagnostic information concerning its radio receive link upon initiation of a diagnostic sequence from the central control point by an E-864/M Encoder and Status Display. In response to carrier-only and tone sequence, the ESC-864 PC board examines its receive signal-to-noise ratio and transmits this information back to the central control point.

4.1.7 Radio Receiver/Transceiver (option)

The radio receiver/transceiver is typically installed in the ESC-864 housing. The radio receiver/transmitter option is available at low band VHF (30-50 MHz), high band VHF (150-170 MHz), or UHF (450-470 MHz).

4.1.8 Local Microphone Input and Volume Control

The local microphone controls are mounted on the front panel of the ESC-864 housing, to allow the user to plug in a microphone to access the public address channel of the SIPS. While it may be obvious that the microphone plugs into the jack, and that the microphone volume control knob allows for adjustment of the output level, a clipping indicator above the microphone volume control knob is provided to indicate the distortion level of the microphone. During PA, the clipping indicator should be flickering on and off (i.e., operating at minimal illumination levels).

4.1.9 System Diagnostics

All SIPS systems are equipped with diagnostic capabilities. The diagnostics provide a basic summary of the system operations concerning AC power, DC power, speakers, and power amplifiers. As previously described, the information from the diagnostics is presented by the various LEDs on the front panel of the ESC-864 housing or on the Supervision Board, inside of the cabinet.

4.2 Power Amplifier Operation

The power amplifiers are located on the backside of the front panel of the SIPS. As previously stated, one 400 W power amplifier is used in a SIPS-400, while a SIPS-800 is equipped with two power amplifiers. Each power amplifier has four (4), 100 W speaker channels, for a total of 400 watts per amplifier.

Each power amplifier is powered by 24 VDC. The amplifiers are hard-wired to the system driver board. Each power amplifier is protected by a 30 Amp fuse, near its connectors. The failure of one amplifier does not cause the failure a

second amplifier; however, all four power amplifier channels within a faulty power amplifier will fail in the case of a blown fuse.

Each power amplifier is mounted on the backside of the front panel so that four (4) red LEDs are visible (on the front side of the front panel), one for each 100 W channel of each power amplifier. These LEDs are used to monitor the electrical circuit between a power amplifier channel and its respective speakers, or the Supervision Board. For line level applications, the LEDs indicate a complete circuit from the respective power amplifier channel to the speakers and back when the power amplifier is in operation. An active LED indicates that the power amplifier channel, system driver board, speaker wires, and speaker(s) are functioning when a warning signal tone or public address mode is active.

In the public address mode of operation, each appropriate power amplifier channel(s) increases its amplification output by an additional 25% to compensate for the differential in power between voice audio signals and siren warning signals. This increase in amplification assists in providing voice broadcasting at warning signal tone ranges.

4.2.1 Speaker Configurations

The SIPS power amplifier(s) can be connected to various speakers and speaker configurations or arrangements. The table below shows some common speakers and the number of speakers allowed per each 100 W channel on each power amplifier.

Common Speakers and Speaker Arrangements

SPEAKER DESCRIPTION	MAXIMUM SPEAKERS PER CHANNEL
The WS15TC/WS30TC are weatherproof, 15 to 30 watt re-entrant loud speakers with multi-tapped transformers and isolation capacitors, for line level supervision applications. The WS15/WS30 do not have transformers or capacitors. These are usually used with SpeakerNodes, for device level supervision.	6: WS15TC or WS15 3: WS30TC or WS30
The WS15TRC/WS15TENC are 15 watt re-entrant loudspeakers with multi-tapped transformers and isolation capacitors for line level supervision applications. The WS15R/WS15REN are 15 watt re-entrant loudspeakers without multi-tapped transformers and isolation capacitors for device level supervision, with Speaker Nodes. The WS15TRC or WS15R speaker is ideal for recessed mounting applications. The WS15TENC or WS15REN speaker is for recessed mounting in ceiling tiles.	6: WS15TRC or WS15R 6: WS15TENC or WS15REN
The WS100TCC Heavy Duty weatherproof, 100 watt wide-angle re-entrant speaker with multi-tapped transformer and isolation capacitor, for line level supervision applications. The WS100CH does not have the transformer or capacitor and is usually used with a SpeakerNode, for device level supervision.	1: WS100TCC or 1: WS100CH
The WSX60TC or WSXPL60 loud speaker is used in areas having explosive or combustible atmospheres. The WSX60TC speaker is a 60 W re-entrant, wide-angle loud speaker and has a multi-tapped transformer and capacitor for line level supervision. The WSXPL60 does not have the transformer or capacitor, and is usually used with a SpeakerNode, for device level supervision.	1: WSXPL60T

Individual product descriptions may be requested from the sales office, for each speaker in the table.

4.3 System Driver Board

The system driver board, shown to the right, provides a number of interconnect functions in the SIPS. The functions are described in paragraphs 4.3.1 through 4.3.3.

4.3.1 SIPS Silent Test Operation

The SIPS can produce an inaudible tone for system testing purposes. The function of this feature, which may be initiated by pressing the SI TEST® pushbutton on the front panel of the ESC 864 controller, is to exercise the system speaker drivers in the same manner as a fully powered, audible warning signal.

By pressing the SI TEST® pushbutton, the user may observe the power amplifier LEDs to determine if a complete circuit is active between each speaker (or group of speakers) and the respective power amplifier channel. The silent test may also be initiated by a remote command.

The results of a silent test are presented on the LED displays, on the front panel, as shown in the table.

Silent Test LED Indicators

LED	STATUS	INFORMATION	COLOR
AC	On	AC site power	Red
DC	On	DC power > 19 VDC	Red
PART	On	Partial Speaker Driver/Amplifier Operation	Red
FULL	On	Full Speaker Driver/Amplifier	Red

The diagnostic routine of the SIPS is processed for each inaudible or full power activation of the system, and the diagnostic LED indicators represent the results of the most current activation.

The complete results of the inaudible test are collected and encoded by the ESC-864 PC board for transmission back to the central control point. In addition to the status information mentioned in the table, the ESC-864 also reports the following information via its RF or landline communication link.

- DC Voltage (system battery voltage)
- AC Voltage
- Ambient Temperature, a 2-digit representation
- Receiver Link S/N, a 2-digit representation
- Activation Count

If all of the SI TEST® LED indicators are illuminated following a test, then all diagnostic routines have been successfully completed, verifying proper station operation. The LED display of the SIPS may be programmed to remain on until cleared, or to extinguish after a predetermined time period.

4.3.2 Power Saving Logic

The system driver board also features a power saving device. In the event of a loss of incoming power from an AC source, the system will power itself down after thirty (30) seconds to conserve the batteries by using less energy for standby operation. **Supervision is also shut down in the event of loss of AC.** When AC is restored, the SIPS will automatically revert to full power-up mode and the battery charger re-charges the batteries.

4.3.3 DC Voltage Regulator

The system driver board produces 12 volts DC, from the 24 VDC supply, to power the ESC-864 PC board and the optional radio. A 3 amp fuse is in line with the 12 volt DC supply.

4.4 Supervision Board Operation

The supervision board is comprised of eight speaker audio channels and two strobe channels. Each channel has a set of fault indicator LEDs. In addition, there is a set of jumpers to control strobe light operation and a dip switch to disable unused speaker channels.

4.4.1 Speaker Channels

Each speaker channel consists of six connections and four LED indicators, as shown. For a line level supervision application, only Audio+ and Audio- are used. For device level supervision, all six connections are used.

Audio+ and Audio- connect to the speakers or to the SpeakerNode, if in use. Status/ and Status Rtn are the connections from the SpeakerNode status relay closure. VDC and Ground are the nominal 24 volt DC power for the SpeakerNode.

The LED indicators are normally off. An illuminated LED, on the super- vision board, indicates a problem. **Speaker faults** are defined below:

The **Amplifier LED** means that the Power Amplifier, associated with the particular channel, is not producing audio.

The **Open LED** indicates that the two wire audio path, for the associated channel, is an open circuit.

The **Short LED** indicates that the two wire audio path, for the associated channel, is short circuited.

The **Status Feedback LED**

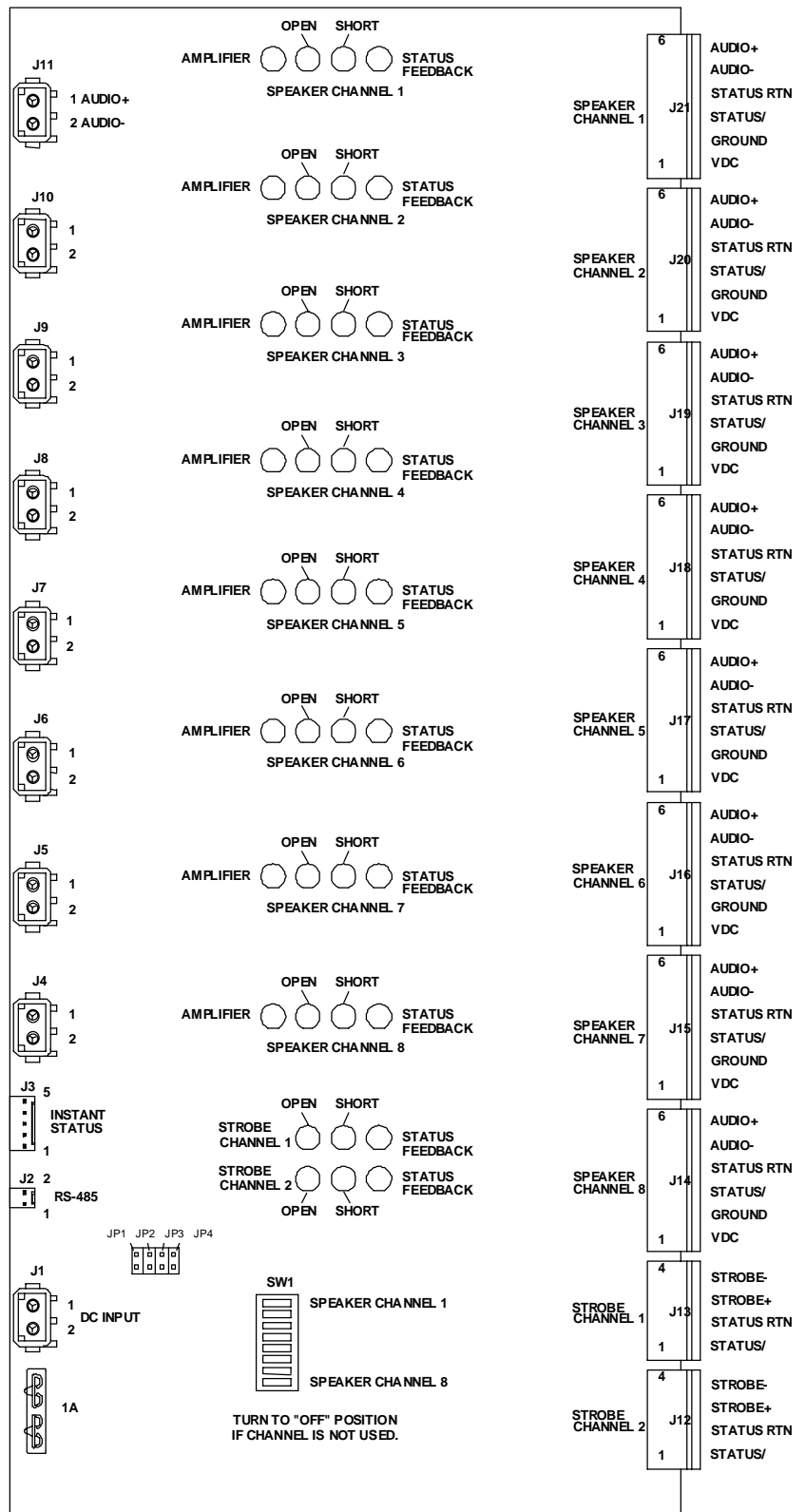

indicates that one of the SpeakerNodes, associated with the channel, has determined a failure in a speaker. This LED applies to device level supervision only. The faulty speaker is located by finding the SpeakerNode with an active fault indicator LED.

Note: The Amplifier LEDs may be on after resetting power to the SIPS. Activate a siren tone or SI TEST®, two times, to cause the LEDs to assume an accurate state.

4.4.2 Strobe Channels

Each strobe channel consists of four connections and three LED indicators, as shown. For a line level supervision application, only Strobe+ and Strobe- are used. For device level supervision, all four connections are used.

Strobe+ and Strobe- are outputs to control a StrobeNode. Status/ and Status Rtn are connections from the StrobeNode status relay closure, for device level supervision.

Note: The Strobe channel **does not** directly power a strobe light. A StrobeNode must be used, for line level or device level supervision.

The LED indicators are normally off. An illuminated LED, on the supervision board, indicates a problem. **Strobe faults** are defined below:

The **Open LED** indicates that the two wire strobe control path, for the associated channel, is an open circuit.

The **Short LED** indicates that the two wire strobe control path, for the associated channel, is short circuited.

The **Status Feedback LED** indicates that one of the StrobeNodes, associated with the channel, has determined a failure in a strobe light or StrobeNode. This LED applies to device level supervision only. The faulty device is located by finding the StrobeNode with an active fault indicator LED.

4.4.3 Strobe Control Jumper Settings

There are four jumpers on the Supervision Board that control strobe light operation. All strobe lights operate the same way.

JP1 (installed)	Enables strobelights by SI-TEST® command.
JP1 (removed)	Default**
JP2 (installed)	Enables strobelights by activation of warning tones.
JP2 (removed)	Default**
JP3 (installed)	Enables strobelights by voice commands..
JP3 (removed)	Default**
JP4 (installed)	Strobelights are disabled by any CLEAR command to the SIPS.
JP4 (removed)	Strobelights are disabled by a STROBE OFF command only.

**Default condition - Strobelights are turned on by the STROBE ON command only.

4.5 Battery Charger Operation

The battery charger has the primary function of maintaining the system battery supply to full capacity. The battery charger provides 5 Amps of charging current to the batteries. The operational status of the battery charger can be viewed by the DC LED during warning signal tone, activation of the SI TEST®, or when the system is powered up. In addition, a green LED on the charger, indicates proper charging. To maintain optimum battery capacity, the SIPS should be exercised on a frequent basis using SI TEST® and a full-power activation.

4.6 Batteries

The batteries are located in the lower compartment of the SIPS. Two 12 VDC, 31 AH (or greater) Gel type batteries are required to operate an SIPS-400, while two 12 VDC 65 AH (or greater) batteries are required to operate an SIPS-800. Detailed installation information for the batteries is provided in Section 5.

Section 5INSTALLATION

5.0 Installation Instructions

The installation instructions are presented as follows:

- Site Selection
- Receiving/Unpacking the SIPS
- Installation of the SIPS Cabinet
- Conduit Openings for the SIPS Cabinet
- AC Wiring
- Speaker and SpeakerNode/StrobeNode Wiring

These steps are discussed in detail in this section. Once the installation steps are complete, the SIPS is ready for an operational checkout.

5.1 Site Selection

Selecting the site for the SIPS requires careful planning to achieve optimal use, range, and effect of the system. Consider maintenance and future expansion when selecting a cabinet mounting location. In general, wiring for **line** level supervision is easier than **device** level supervision. There is no absolute wire length and wire size for a SIPS installation, however, there are guidelines that should be followed.

Line level wiring –	Two conductor, 18 AWG cable, for 0 to 2000 feet. Two conductor, 16 AWG cable, for 2000 to 4000 feet.
Device level wiring –	Six conductor, 18 AWG cable, for 0 to 1500 feet. Six conductor, 16 AWG cable, for 1500 to 2500 feet.

Wiring to SpeakerNodes and StrobeNodes **should not exceed 2,500 feet**. Also, **no more than four** equally distributed nodes, may be wired into a given channel. The SIPS has eight channels. Since each channel may have up to four SpeakerNodes, the maximum number of SpeakerNodes per cabinet is 32. Note that all of these numbers are typical recommendations. Actual numbers may vary depending on the nature of the installation.

Note that the speaker load of each cable run must not exceed 100 watts. SIPS-400 supports 400 watts and an SIPS-800 supports 800 watts. A more detailed wiring guide is in the Appendix.

The cabinet has mounting tabs or flanges on 14 inch centers, for wall mounting. For outdoor applications, drain holes need to be drilled into the upper compartment of the SIPS. Consult Whelen Engineering Company, Inc. for advice on outdoor applications.

NOTE

As part of the site selection planning process, the local utility company should be consulted with respect to installation of AC service. The location of the SIPS site should be checked for the quality of the AC service and to ensure there will be no electromagnetic interference at the site. Also, AC power sources subject to excessive power surges or transients are not acceptable. A site should also be appraised for antenna placement and for radio reception for systems equipped with RF link interfaces.

5.2 Receiving/Unpacking the SIPS

A SIPS is typically shipped with the following items packed on a single shipping pallet: (a) two, 12 volt, Gel type batteries 31 AH, minimum, for a SIPS-400 or 65 AH, minimum, for a SIPS-800; and (b) the SIPS cabinet with the appropriate electronics, as ordered. If a radio receiver/transceiver was ordered as part of the system, an antenna may be included on the pallet. For multiple-system purchases, pallets may be shipped carrying multiple SIPS cabinets, for example, while other pallets may contain antennas and batteries. Speakers are commonly packaged together and sent simultaneously with the system. Before shipment, each SIPS has been pre-assembled, wired, and tested at the factory. The receiver of any shipment(s) should check each shipment against the purchase order to ensure that a complete system (as ordered) has been shipped.

5.3 Installation of the SIPS Cabinet

The SIPS cabinet is typically mounted to an inside wall of a building. The cabinet is equipped with two mounting flanges on the top and two mounting flanges on the bottom, as shown in the drawing. The top flanges have two 7/16" holes and the bottom flanges have two 7/16" slots, in order to accommodate 3/8" hardware. The holes are on 14" centers.

The SIPS-400 and the SIPS-800 are the same size, however, the SIPS-400 weighs approximately 120 pounds and the SIPS-800 weighs approximately 160 pounds.

Be sure to allow enough room to fully open the cabinet doors. Also, make sure there is room for conduit and wiring, typically on the left side of the cabinet.

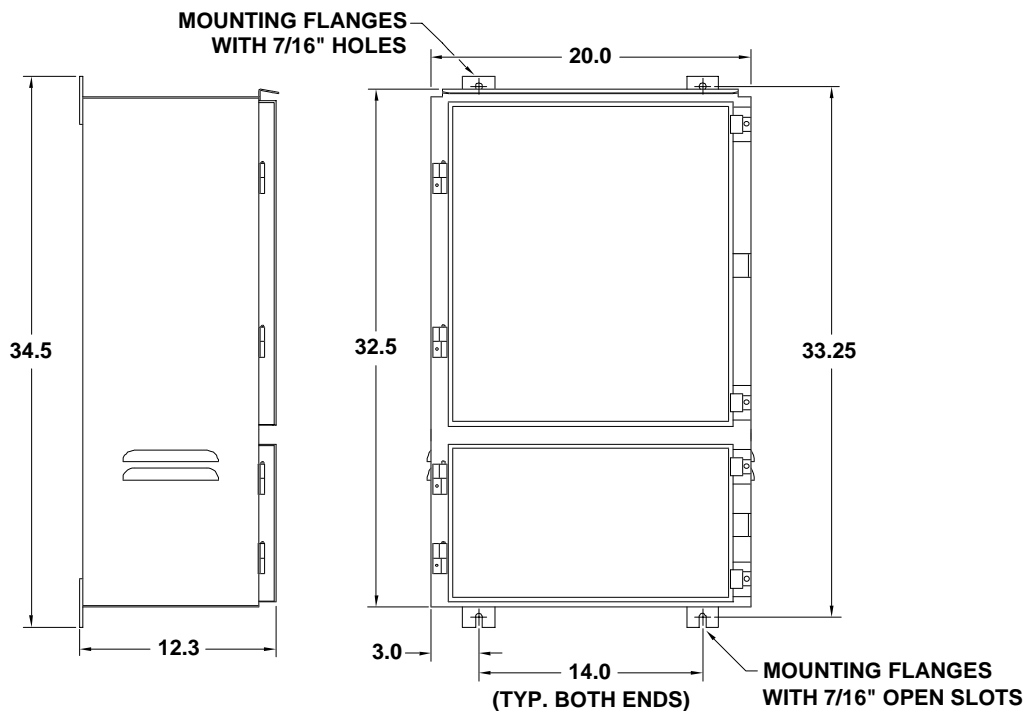

Mounting Details

5.3a Installation of the “Type C” Cabinet

For “Type C” cabinet installation only

The SIPS cabinet is typically mounted to an inside wall of a building. The cabinet is equipped with two mounting flanges on the top and two mounting flanges on the bottom, as shown in the drawing. The top flanges have two 7/16” holes and the bottom flanges have two 7/16” slots, in order to accommodate 3/8” hardware. The holes are on 14” centers.

The SIPS-400 and the SIPS-800 are the same size, however, with a “Type C” cabinet the SIPS-400 weighs approximately 150 pounds and the SIPS-800 weighs approximately 190 pounds.

Be sure to allow enough room to fully open the cabinet doors. Also, make sure there is room for conduit and wiring, typically on the left side of the cabinet.

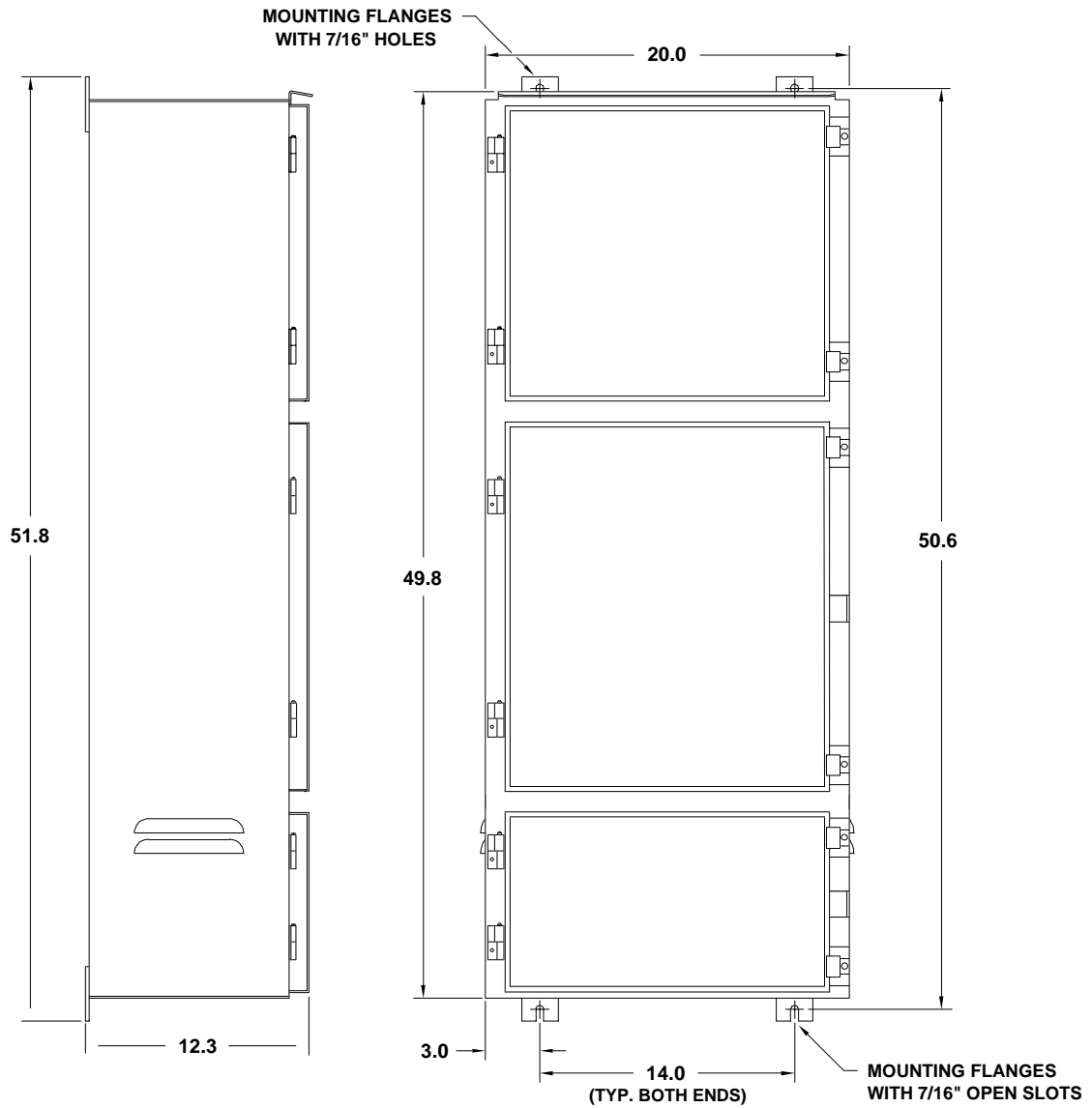

Mounting Details

5.4 Conduit Openings for the SIPS Cabinet

The installer must punch entry holes in the SIPS cabinet. The holes are typically made on the left side of the cabinet, as shown in the drawing.

Note: The location of the holes, the size of the holes and the number of holes is left to the installers discretion. However, the drawing shows the factory's recommendation. Following the factory recommended hole pattern will ensure compatibility with future options or system expansion. Do not try to line up the AC conduit with the AC outlet box in the cabinet.

Refer to the drawing below. Notice the 5" x 7" cross-hatched open area, 3" from the back wall and 5" from the bottom shelf. Locate two holes in the 5" x 7" open area. Working from the inside of the cabinet, drill a pilot hole for each of the holes. Open the top hole to 1 1/4" diameter and the bottom hole to 3/4" diameter.

The 1 1/4" hole is for the speaker conduit. The 3/4" hole is for the AC service and the antenna cable, if an optional radio is installed. Run the speaker conduit to the 1 1/4" hole and the AC conduit to the 3/4" hole. The use of "L" or "T" fittings is advised to simplify routing of speaker wires and the optional antenna cable.

Note: If the cabinet is in an area where it is exposed to water, the conduit fittings to the cabinet must be properly sealed.

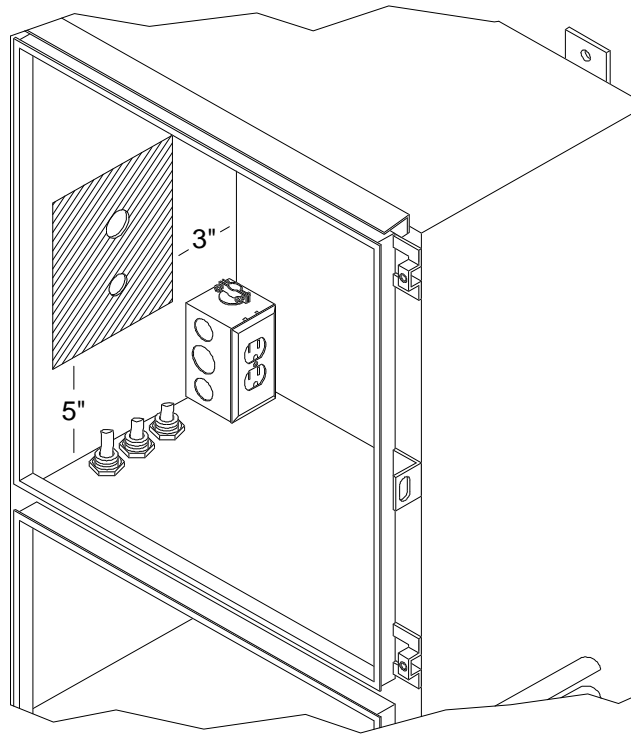

Conduit Hole Location

5.5 AC Wiring

Make sure the battery charger is unplugged from the AC outlet in the left rear corner of the control cabinet. Route the AC service wire through the cable clamp on top of the box. Make the AC connections to the outlet, according to local electrical codes.

Locate the green wire in the outlet box. This is the cabinet chassis ground. Connect the green wire to the ground wire of the electrical service, within the outlet box.

Leave the battery charger unplugged, at this time.

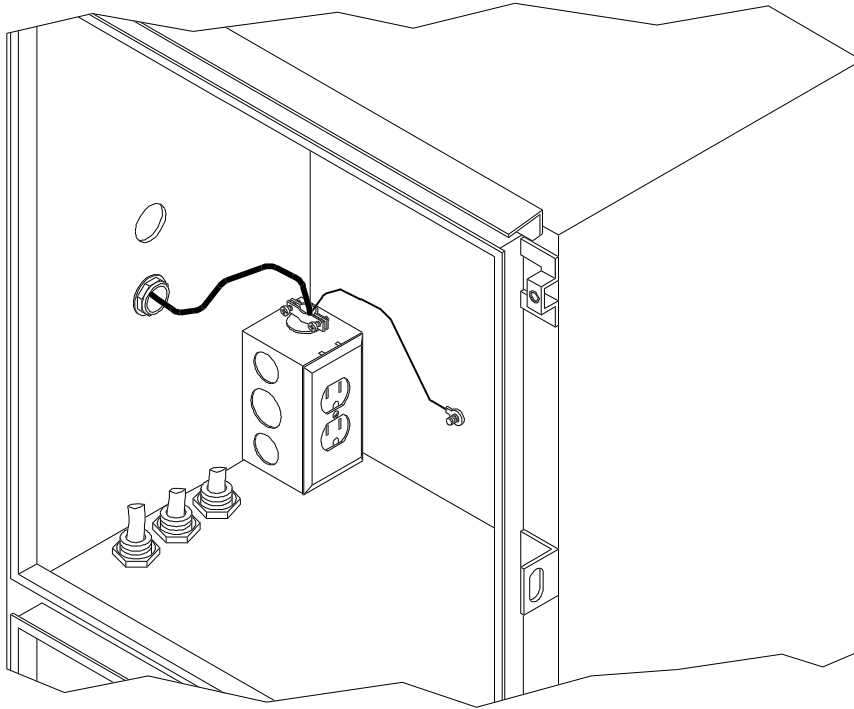

AC Outlet Wiring

NOTE

The electrical service is subject to local codes and conditions. The SIPS requires AC power only for the purpose of operating the battery charger.

5.6 Speaker Wiring

All of the speakers audio connections and device level supervision connections are made through the Supervision Board, located on the right side of the back wall of the SIPS cabinet. There are eight individual 100 watt channels.

Speaker channels may be used for line level or device level supervision. For example, Channels 1, 2 and 3 may be wired to SpeakerNodes, for device level supervision and Channels 4, 5 and 6 may be wired to speakers, with an End-of-Line resistor, for line level supervision. Channels 7 and 8 are not used and have the End-of-Line resistor installed right at the connector.

As shown, there are two connections for audio, Audio+ and Audio-, which connect to the speaker in a line level installation, or to the SpeakerNode in a device level installation.

Status/ and Status Rtn are connected to the SpeakerNode. These signals are used for device level supervision only. Status/ is normally a high level, about 24 volts DC. Status/ low, approximately zero volts, indicates an error condition.

VDC and Ground are the power connections for the SpeakerNode. These signals are used for device level supervision only. VDC is approximately 24 volts. It is protected by a fuse, however, care should be taken to avoid shorting to Ground and to maintain proper polarity at the SpeakerNode.

Each Audio pair can drive up to 100 watts, therefore, speaker loads greater than 100 watts must be distributed through more than one terminal pair.

Unused channels should have the End-of-Line resistor installed at the six position header, Audio+ and Audio- connections. Also, the Dip Switch for the unused channel must be switched to OFF.

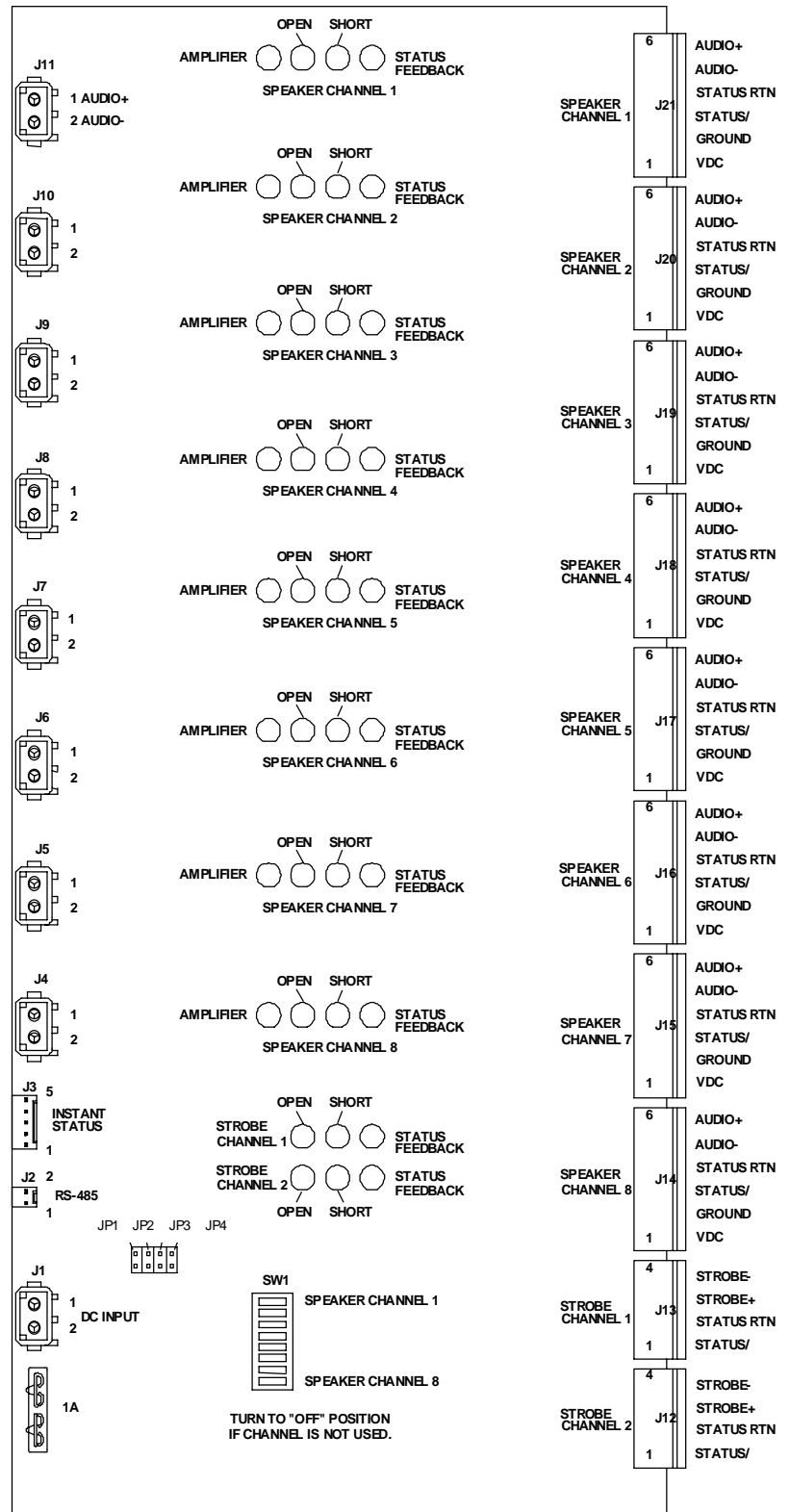

Strobe Channels 1 and 2 are for remote strobe light control and status. These channels do not directly power a strobe light. Strobe+ and Strobe- are the control lines to a StrobeNode. Status/ and Status Rtn are the used for device level supervision only. Status/ is normally a high level, about 24 volts DC. Status/ low, approximately zero volts, indicates an error condition.

Strobelight operation is controlled by Jumpers 1 through 4, as follows, reading left to right:

- JP1 installed - Strobe on with SI TEST®
- JP2 installed - Strobe on with Tones
- JP3 installed - Strobe on with Digital Voice Messages
- JP4 installed - Strobe off with Cancel

5.7 End-of-Line Resistor

The SIPS is shipped with ten (10) 4.7K ohm, End-of-Line Resistor assemblies. The resistor must be installed across the Audio+ and Audio- wires, at the end of each speaker wire run. For the strobe wire runs, the End-of-Line resistor is placed across the Strobe+ and Strobe- wires, at the end of the run. If a speaker or strobe channel is not used, the

End-of-Line resistor should be placed across the unused connector on the Supervision board.

Section 6 BATTERIES

6.0 Battery Installation

As previously mentioned, an SIPS-400 comes with two 31 Amp-hour batteries. These fit as shown in the drawing. The SIPS-800 comes with two 65 Amp-hour batteries. These are larger than the 31 Amp-hour batteries. They must be rotated 90 degrees to be installed.

CAUTION: Do not allow battery terminals, cables terminals or uninsulated tools to make contact with the aluminum cabinet.

6.1 Battery Connections

Unplug the battery charger from the AC outlet. Connect the red cable to the (+) terminal of the left battery. Connect the black cable to the (-) terminal of the right battery. Lastly, connect the interconnect cable to the (-) terminal of the left battery and then the (+) terminal of the right battery.

Note: A spark may occur when the last terminal connection is made.

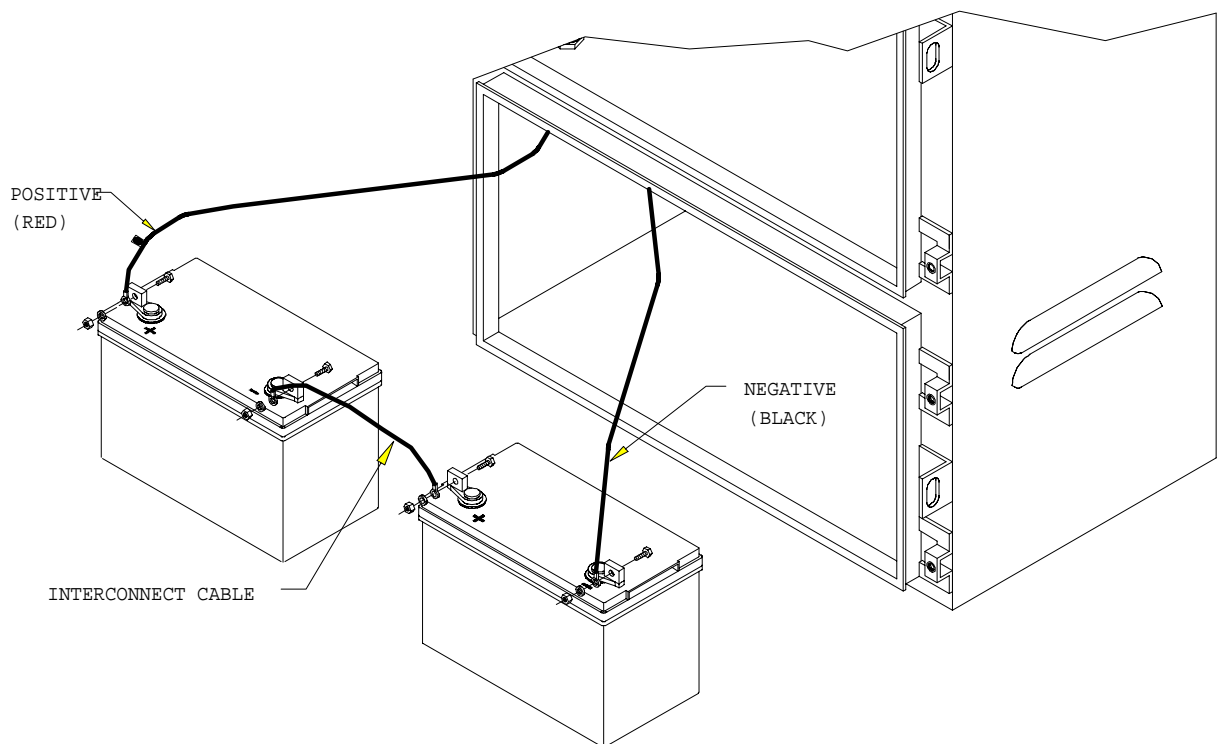

Battery Compartment Connections

Section 7 CONTROLLER PROGRAMMING

7.0 ESC 864 Controller Programming

This section covers user programmable features of the ESC-864 controller, in the SIPS. A number of parameters are factory set in Electronically Erasable Programmable Read Only Memory (E²PROM) others are controlled by Dip Switch settings.

7.1 User E²PROM Programming

Certain parameters of the SIPS may be user programmed to adapt the system to specific needs. User programming is accomplished by inputting information to the ESC 864 controller board using a Whelen MDK-864. (The "MDK" in the Whelen MDK-864 stands for Microprocessor Diagnostic Keyboard.) Factory settings for each SIPS are included on the Test Sheet, shipped in the upper compartment of the SIPS. Refer to the manual on the MDK-864 for parameter changes. Use of the Whelen MDK-864 is discussed in the manual, **MDK-864 Microprocessor Diagnostic Keyboard**.

Since the programming variations are too numerous to address in this manual, the remainder of this section is intended to acquaint a SIPS user with the basic options available for user-definable programming.

7.2 ESC 864 Encoding/Decoding Parameters

The SIPS is equipped for remote activation and status reporting. The SIPS requires programming to recognize commands from, and to report status to, a central control point. The SIPS may also be programmed to operate in a multiple-system network, where each SIPS cabinet has a specific identification code. The SIPS Test Sheet, that accompanies each SIPS indicates the following access and identification information:

- System: Area Code (3 digits)
- Station: Address Code (4 digits)
- Substitute Number:
- Transmit Delay:

This information is programmed into the ESC-864 controller E²PROM at the manufacturer's facilities.

7.3 Warning Tone Timer Programming

The ESC-864 board determines run time duration for each siren tone and for the PA announcement. The typical factory setting is three minutes. The Test Sheet, that accompanies each SIPS, indicates timer settings.

NOTE

The Test Sheet identifies tones only as Tone 1, Tone 2, etc. For purposes of clarity, these tones are identified below as column two.

Warning Tone Signal/PA Announcement Timing Information

TONE	SIGNAL	DURATION*
1	WAIL	__ -- ____
2	ATTACK	__ -- ____
3	ALERT	__ -- ____
4	PA	__ -- ____
5	AIR HORN	__ -- ____
6	HI/LO	__ -- ____
7	WHOOOP	__ -- ____
8	NOON TEST**	__ -- ____

*Duration is indicated as: Minutes (_) and Seconds (_ _). Unless otherwise specified by the customer, the standard factory programming is for an event duration of three minutes (3-00), with the exception of the five-second test.

**NOON TEST is referred to as a 5 SEC WAIL on the front panel of the ESC-864.

7.4 DIP Switch Programming

The ESC-864 controller board has two, eight-position dip switches. The switches are set by the manufacturer in accordance with the user's application and the software/hardware options that are installed into the system at the time of manufacture. The dip switches control function settings and instant status settings. The Test Sheet, included with each SIPS, refers to these settings as Function Dips (SW 1) and Status Dips (SW 2).

Note: Instant Response, DIP position 6, must be ON for a supervision system.

Function Dips (SW 1) Programming Functions

Position	Function	Setting/Use
1	Not Used	Off
2	Decoder Format	On (10 digit) Off (8 digit)
3	SI TEST® LED	On (30 sec clear)/Off (latch)
4	Warning Signal (Siren) Type	On (oscillating) Off (stationary)
5	AC Battery Check	On/Off
6	Instant Response	<u>On</u> /Off
7	Immediate Response	On/Off
8	Master XMT	On/Off

Instant Status Dips (SW 2) Programming Functions

Position	Function	Setting/Use
1	AC	On/Off
2	Intrusion	On/Off
3	Strobe	On/Off
4	General Fault	<u>On/Off</u>
5	not used	
6	Full	On/Off
7	Partial	On/Off
8	Tone Gen Bias	On/Off

Note: General Fault, DIP position 4, must be ON for a supervision system.

Section 8 SPEAKERNODE

8.0 SpeakerNode Installation

Select a location for the SpeakerNode within 50 feet of its associated speaker. A SpeakerNode is approximately 7.0" W x 7.0" H x 4.0" D. Be sure to leave room for cable clamps, as described below. There is an advantage to mounting in an accessible place since there is an LED indicator visible on the left side of the enclosure. Loosen the captive screws and remove the cover to proceed.

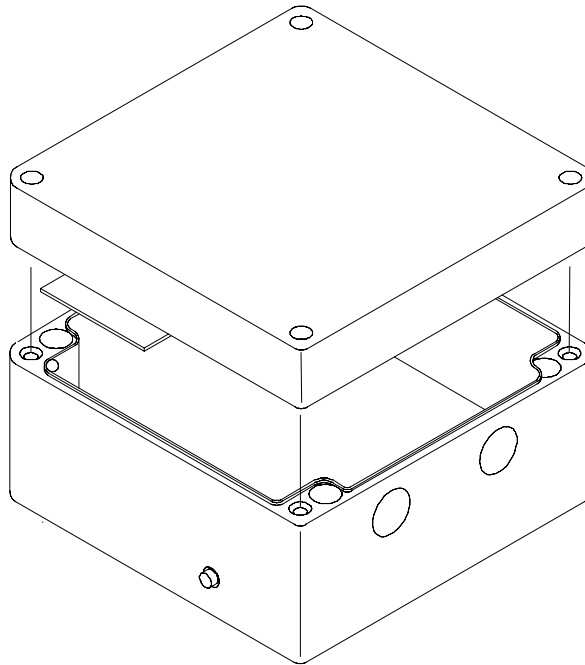

The SpeakerNode is shipped with two 3/4" NPT cable holes, on the bottom, and one 1/2" NPT speaker wire hole on top. Route the 6 conductor system cable through the bottom left hole. Connect Audio+ and Audio- at the four position header, connect VDC, Ground, Status/ and Status Rtn at the eight position header. Route the speaker wire through the top hole. Use wire nuts to connect to the Red and Black speaker wires in the SpeakerNode.

The LED indicator is normally Green. An error condition is indicated by Red.

Each signal, from the control cabinet, has a dual terminal to allow for proper "daisy-chain" wiring in a supervised installation.

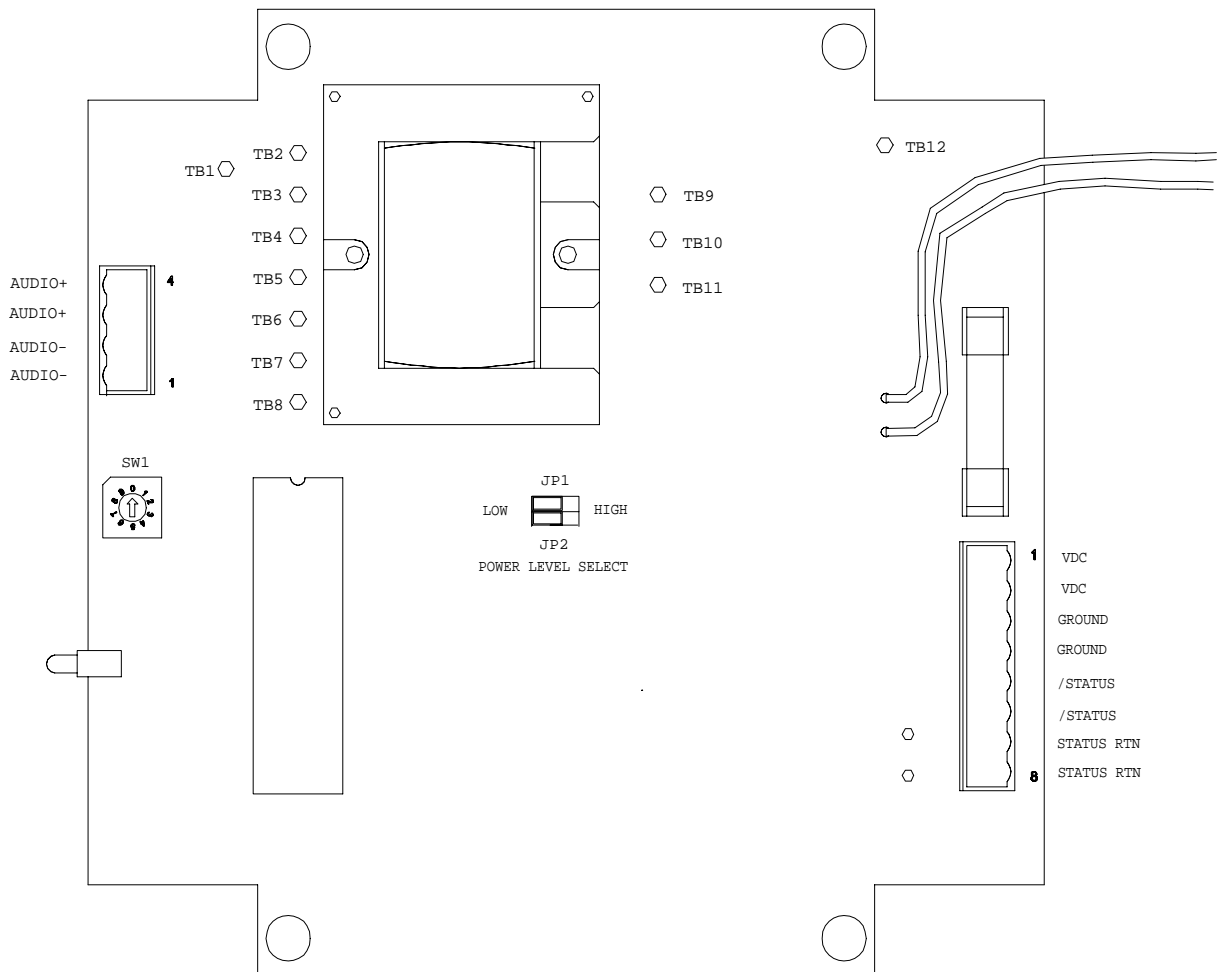

8.1 - SpeakerNode Power Settings

The SpeakerNode contains a group of jumpers that allow the installer to select speaker output power (or sound level output) and the speaker power rating.

The speaker output power is controlled by the tap setting of the audio transformer in the SpeakerNode. The output power setting is directly related to the sound output of the speaker. The following pages show tables for output power vs. tap settings and sound level output vs. tap settings. In addition, these pages show how to set the power rating for various speaker types.

Note: Setting the power rating incorrectly may greatly reduce the life of the speaker driver.

Table 1 is for Model # SPKN030, typically 15 and 30 watt speakers. Table 2 is for Model # SPKN100, typically 60 or 100 watt speakers.

Refer to the drawing and Tables 1 and 2. Select the tap setting, for sound level, by moving the jumper to connect TB1 to the desired setting (ie. TB2, TB3, ...). Select the speaker power rating by moving the other jumper to connect TB12 to the desired setting (ie. TB9, TB10 or TB11).

Two small black jumpers, JP1 and JP2, must be set depending on the output power setting of transformer. If the output power is less than or equal to 3.75 watts, the jumpers must be in the LOW position. Greater than 3.75 watts equals the HIGH position, for both jumpers. The output power is calculated by dividing the maximum speaker power by the tap setting factor.

For example: A 30 watt speaker, set at TB5. Referring to the chart, the tap setting factor is 8:1, therefore, $30/8=3.75$ watts. Set JP1 and JP2 to the LOW position.

Model # SPKN030 SpeakerNode

WS 15 Series vs. AUDIO TRANSFORMER TAP SETTINGS

TAP SETTINGS	TB1- TB8	TB1- TB7	TB1- TB6	TB1- TB5	TB1- TB4	TB1- TB3	TB1- TB2
OUTPUT TAP FACTOR	1:1	2:1	4:1	8:1	16:1	32:1	64:1
SOUND LEVEL (dBA)*	116	114	111	109	106	103	100

WS 30 Series vs. AUDIO TRANSFORMER TAP SETTINGS

TAP SETTINGS	TB1- TB8	TB1- TB7	TB1- TB6	TB1- TB5	TB1- TB4	TB1- TB3	TB1- TB2
OUTPUT TAP FACTOR	1:1	2:1	4:1	8:1	16:1	32:1	64:1
SOUND LEVEL (dBA)*	121	119	116	113	111	108	105

The Output Power is the maximum power output of the speaker divided by the Tap Factor.
For example: 30 Watt speaker / 16:1 = 1.875 Watts).

* Measured at a distance of 4 feet, measurements given in dBA with WAIL tone.

AUDIO TRANSFORMER OUTPUT TAPS vs. SPEAKER POWER RATING

SPEAKER RATING	7.5 WATT @ 8 OHMS	15 WATT @ 8 OHMS	30 WATT @ 8 OHMS
OUTPUT JUMPER	TB12 - TB11	TB12 - TB10	TB12 - TB9

Model # SPKN100 SpeakerNode

WS 60 Series vs. AUDIO TRANSFORMER TAP SETTINGS

TAP SETTINGS	TB1- TB8	TB1- TB7	TB1- TB6	TB1- TB5	TB1- TB4
OUTPUT TAP FACTOR	1:1	2:1	4:1	8:1	16:1
WS 60 SOUND LEVEL (dBA)*	124	121	119	116	113
WSXPL 60 SOUND LEVEL (dBA)*	123	120	118	115	113

WS 100 Series vs. AUDIO TRANSFORMER TAP SETTINGS

TAP SETTINGS	TB1- TB8	TB1- TB7	TB1- TB6	TB1- TB5	TB1- TB4
OUTPUT TAP FACTOR	1:1	2:1	4:1	8:1	16:1
WS 100 SOUND LEVEL (dBA)*	131	128	125	123	120
WS 100CH SOUND LEVEL (dBA)*	130	128	125	123	120

The Output Power is the maximum power output of the speaker divided by the Tap Factor.

For example: 100 Watt speaker / 8:1 = 12.5 Watts).

* Measured at a distance of 4 feet, measurements given in dBA with WAIL tone.

AUDIO TRANSFORMER OUTPUT TAPS vs. SPEAKER POWER RATING

SPEAKER RATING	60 WATT @16 OHMS	100 WATT @ 11 OHMS	60 WATT @ 8 OHMS
OUTPUT JUMPER	TB12 - TB9	TB12 - TB9	TB12 - TB11

8.2 - SpeakerNode Switch Setting

At installation, the Speaker Type switch must be set. This switch is shown, as SW1, in the drawing. Refer to the table.

SPEAKER TYPE SWITCH SELECTION

SPEAKER TYPE	SWITCH POSITION
WS100	0
WS100CH	1
WS15 SERIES	2
WS30	3
WSXPL60	4
WS60	5
4 OHM GENERIC SPEAKER	6
8 OHM GENERIC SPEAKER	7
16 OHM GENERIC SPEAKER	8
45 OHM GENERIC SPEAKER	9

Section 9 STROBENODE

9.0 StrobeNode Installation

Select a location for the StrobeNode within 50 feet of its associated strobe light. A StrobeNode is approximately 9.5" W x 7.5" H x 4.6" D. Be sure to leave room for cable access and cable clamps. There is an advantage to mounting in an accessible place, since there are three LED indicators that are visible through the clear section of the cover. Remove the cover from the wiring compartment to proceed.

The installation will need three separate cables. One for AC service, one for the connections to the SIPS control cabinet and one for driving the strobe light. Follow local codes regarding the use of conduit, when wiring to the StrobeNode. Use wire nuts to make the connection in the wiring compartment. Route a four wire cable for the connections between the StrobeNode and the SIPS cabinet. Follow the wiring diagram on the inside of the StrobeNode cover. Route a two wire cable from the strobe light. Connect the strobe light positive voltage wire to the Orange Strobe (+) wire. Connect the strobe light ground wire to the Black Strobe (-) wire. The Strobe (-) wire is the black wire, without the label. Connect the AC service to the white and black wires, that have the "115V" labels.

Each signal, from the control cabinet, has a dual terminal to allow for proper "daisy-chain" wiring in a supervised installation.

The StrobeNode is shipped with two small, sealed, gel-type batteries. The batteries are installed and wired in series, however, the batteries are not connected to the circuit. Locate the 5 Amp, 3AG type fuse and install it in the in-line fuse holder.

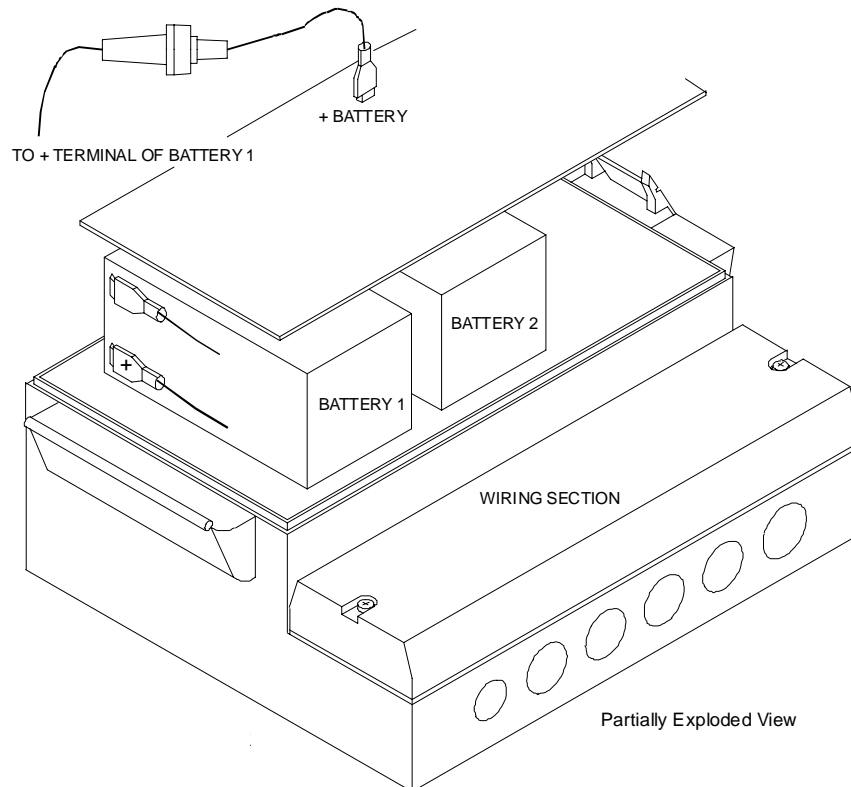

9.1 StrobeNode Switch Settings

The following operations take place on the StrobeNode printed circuit board. Open the clear, hinged cover to access the board.

Set the AC voltage jumpers for the proper AC service, as shown in the drawing.

Install a jumper from JP1 to JP2 and from JP3 to JP4, for 115 VAC operation. Install a jumper from JP2 to JP3 for 220 volt operation.

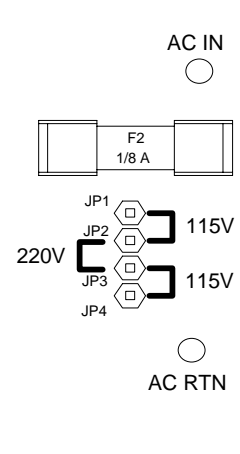

At installation, the Address and Strobe Type must be set. These switches are shown in the drawing to the right.

SW1 is the strobe type setting. Refer to the table below.

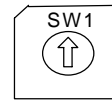

STROBE TYPE SWITCH SELECTION

STROBE TYPE	SWITCH POSITION
ISB24 (SuperStrobe)	0
WSHX024	1

Section 10 TESTING & TROUBLESHOOTING

10.0 System Testing and Troubleshooting

Throughout this section, testing and troubleshooting pertain to operational checkout procedures and fault-isolation procedures. Successful completion of the operational checkout verifies proper operation of the SIPS. Tables 10-1 through 10-2 correlate faults to isolation procedures and associated corrective action. Troubleshooting procedures are presented under the assumption that there is but one malfunction at a time. After all repairs are made, an operational checkout of that malfunctioning module should be repeated to make sure that any module replacement did not introduce a new malfunction.

The silent test feature is the key to system checkout and testing. If the SI TEST® does not isolate the problem, follow the procedures below to assist in further fault isolation testing and troubleshooting. If the procedures in these subsections do not isolate the fault, a more detailed diagnostic/testing tool, the MDK-864, or Microprocessor Diagnostic Keyboard, is used by a trained technician to isolate the problem.

10.1 Initial Operational Checkout

PROCEDURE NUMBER AND TOPIC	PROCEDURAL ACTIVITIES
1: Batteries	Check the series connection between the batteries in the SIPS lower compartment.
2: AC Service	Make sure there is a proper connection between the AC service and the AC workbox.
3: Power Check	If there is a dedicated AC disconnect switch, ensure that the switch is in the ON position.
4: Functional Observation	Activate a local SI TEST® to verify that the SIPS is operating properly.

10.2 System-Level Faults and Troubleshooting Procedures

The system-level faults, isolation procedures and corrective actions are intended to assist in isolating the cause and location of a failure within the SIPS control cabinet, as well as any associated warning devices.

NOTE

In troubleshooting the SIPS, the user is reminded that certain procedures and tests may cause the SIPS to produce an audible signal. The user should exercise discretion regarding the production of warning signals. Most of the troubleshooting procedures may be performed without producing an audible signal.

System-Level Faults and Troubleshooting Procedures

FAULT	ISOLATION PROCEDURE	CORRECTIVE ACTION
SIPS will not activate via local controls.	Determine whether battery voltage is less than 19 VDC.	Perform battery system faults and troubleshooting procedures. If batteries do not attain and maintain 19 VDC, replace batteries.
Battery voltage is less than 19 VDC.	Verify 120 VAC present. Check the fuse on the battery charger.	Supply 120 VAC service. Replace the fuse.
SIPS will not activate via local controls. PWR LED is on.	Observe all wiring and connections.	Repair or replace broken cabling/wiring between modules. If wiring or circuitry within a module appears damaged, contact manufacturer's service personnel.
SIPS will produce tones which are audible near the cabinet, but fail to produce tones at designated sound levels.	Check the tone generator connector to the system driver board, including the cable leading to the ESC-864 case. Check the power amplifier cables and connections. Inspect power amplifier fuses. Observe speaker driver (i.e., wire) connections to terminal strip on the system driver board.	Refit the tone generator connector. Check cable/wiring path between tone generator connector and connection to ESC-864. If damaged, have repaired or replaced. Check cable/wiring path between power amplifier connections on the power amplifier(s) and the associated connections on the system driver board. If loosened on the power amplifier(s), make proper connection. If loosened or damaged on the system driver board, have manufacturer's personnel repair or replace. Replace fuse(s), as required. Make proper connections. If damaged, have wires repaired or replaced. If problem not resolved, refer to manual on speakers. If speakers check out properly, contact manufacturer service personnel.
No LEDs on the supervision board illuminate <u>during</u> signal activation.	Observe the supervision board fuse.	Replace fuse. Replace supervision.
One (or more) amplifier LEDs, on the supervision board, remain illuminated after signal activation.	Observe connections of speaker drivers to the supervision board. Inspect associated power amplifier fuse.	If connections are proper and not damaged, swap the two position connector from an adjacent, working power amplifier into the suspect power amplifier channel on the supervision board. Re-test. Swap out the faulty amplifier if the problem follows to the new channel.
Some/all power amplifier and SI TEST® LEDs do not illuminate or operate properly during signal or	Observe speaker driver loading levels.	If speaker drivers are not operating at proper capacity because of insufficient loading, power amplifier and SI TEST® LEDs <u>Will not</u> operate effectively. Observe the Amplifier LED on the supervision board instead or temporarily increase the output load.

FAULT	ISOLATION PROCEDURE	CORRECTIVE ACTION
silent test activation.		
SIPS will not activate via remote controls (i.e., RF or landline).	Attempt local activation via pushbutton controls on the ESC 864 front panel.	<p>If local activation works, check RF paths and antenna connections for systems with RF link. If problem is not resolved, refer to SIPS Remote Activation Faults and Troubleshooting Procedures.</p> <p>If local activation works for systems with landline interfaces, clean and reconnect interfacing connections. If problem not resolved, replace line.</p>

10.3 SIPS Remote Activation Faults

Once it has been established that the SIPS will operate via local controls, several conditions concerning remote controls or remote activation link faults may be examined.

Part A. Central Control Point

SIPS will not activate via RF link.	<p>Localize the fault to either the central control point or the remote (i.e., SIPS cabinet) station/site.</p> <p>Determine the fault(s) within the central control point side of the RF link.</p>	<p>Ensure that central control point transmitter and encoder are ON.</p> <p>Verify that the central control point transmitter and SIPS station/site address code is selected on the central control point encoder.</p> <p>Verify that the correct SIPS station/site address code is selected on the central control point encoder.</p> <p>If more than one SIPS station/site exist in the communication system setup, determine that the encoder will address an SIPS cabinet not in question. If the encoder will address one or more SIPS cabinet stations, excluding the one cabinet station that will not activate, perform the troubleshooting steps concerning the SIPS cabinet station side of the RF link. (Refer to Part B below.)</p> <p>Listen to the activation link transmission from a monitor or radio receiver on the activation link frequency.</p> <p>Send a CANCEL command.</p> <p>Verify that the DTMF tones are audible on the monitoring device.</p> <p>If the result of the above step is negative, inspect the audio connection between the encoder and transmitter and the encoder PTT circuit.</p>
SIPS will not activate via RF link (con't.).	Determine whether the encoder's DTMF tones are being modulated by the transmitter.	Obtain assistance from a radio service facility. Using an FM test set, ensure that the DTMF tone level modulation is set at 2.5 KC. If tone squelch is utilized, the modulation factor for the tone squelch should be added to the DTMF tone level set up.

Part B. SIPS Cabinet Station Link

FAULT	ISOLATION PROCEDURE	CORRECTIVE ACTION
SIPS will not activate via RF link.	<p>Determine the fault(s) within the SIPS cabinet/station side of the RF link. First determine whether the encoder's DTMF tones are audible at the SIPS cabinet/station.</p> <p>If the DTMF tones are audible or the monitoring device at the SQ LED illuminates, determine whether DTMF tones are being received and processed.</p>	<p>Using a monitoring device, have the central control point dispatcher send a CLEAR command. If the DTMF tones are audible on the monitoring device, perform the following step. If the tones are not audible, skip to the next step.</p> <p>Have the DTMF tone transmitted again and observe the SQ (squelch) LED. If the SQ LED illuminates, this situation indicates that the SIPS cabinet station is receiving the transmission.</p> <p>If the tone is not being received at the monitoring device or the SIPS cabinet station, consider the RF link path and propagation.</p> <p>Have the central control point dispatcher send another CLEAR command. If the DEC (decoder active) LED flashes, this situation indicates that DTMF tones are being received and processed.</p>
SIPS will not activate via RF link (con't.).	If the SQ LED or DEC LED do not flash, verify radio connections.	Correct radio connections.
SIPS will not activate via RF link (con't.).		If the prior three steps do not determine the fault(s) or resolve the problem, contact manufacturer's service personnel.

Section 11 REPLACEMENT

11.0 Replacement Procedures

SIPS repair is covered at the module replacement level. Component level repair is not recommended. Nodes, speakers and strobe lights are replaced at the final assembly level.

CAUTION

The SIPS cabinet is a high-voltage unit. Wait five minutes after turning off AC power and disconnecting the interconnect battery cable before removing any module. **DO NOT** allow the battery cable to **touch** the aluminum cabinet.

The replacement information is presented for the following modules: The part number is provided for reference. Contact the sales office for replacement parts and current revisions.

- ESC-864 Controller Part # 01-0285357-00C
- System Driver Board Part # 02-0168449-00C
- Supervision Board Part # 02-0168296-00C
- Power Amplifier(s) Part # 01-0285564-00C
- Battery Charger Part # 01-0285772-00C
- Batteries Part # 44-0712011818C for SIPS-400.
 Part # 44-0712015649C for SIPS-800.

11.1 ESC 864 Controller Replacement

The ESC-864 is typically replaced at the module level. Individual board level replacement is not recommended or discussed in this section.

To replace the module, unscrew the two screws to the immediate right of the ESC-864 front plate. Remove all connectors from the controller. Mark the connectors to ensure proper reinstalling. Lift the controller housing directly upward, off of the L-shaped bracket. Reverse the procedure to install a new controller.

11.2 System Driver or Supervision Board Replacement

Label all output connectors before removing them from the Supervision Board. Remove mounting hardware. Replace the board by reversing the procedure.

11.3 Power Amplifier Replacement

Remove the connectors from the Power Amplifiers. Remove the one screw on the ESC-864 front panel, immediately above the Power Amplifier LEDs. Lift the Power Amplifier upward off of the L-shaped bracket. Reverse the procedure to install a Power Amplifier.

A Power Amplifier is heavy. Be sure to have a firm grip on it before removing the mounting hardware.

11.4 Battery Charger Replacement

Make sure that the AC power cord is unplugged. Disconnect the cables. Remove four nuts from the back wall of the charger. Reverse the procedure to install the Charger.

Section 12 INSPECTION

12.0 Routine Inspection

Routine inspection procedures for the SIPS pertain to the basic SIPS cabinet, mainly cables and connectors. Inspection or checkout procedures for specific modules are provided below.

Routine Inspection Procedures

PROCEDURE AND TOPIC	PROCEDURAL ACTIVITIES
Cable Inspection	Inspect all cables and connectors (i.e., from the AC Service to the system driver board within the SIPS cabinet and all other plainly exposed cables and connections) for visible damage that might affect safety and operation. This visible inspection should ensure that no wires have been cut and that no connector has shorted or has loosened from its respective cable.
Connector Inspection	Inspect all connectors for bent or broken pins and corrosion. Also, inspect all connectors for damaged threads.
Cabinet Inspection	Inspect all plainly visible aspects of the SIPS cabinet to ensure that no damage or corrosion has occurred. Ensure that no mounting bolts, washers or nuts are loose or missing. Tighten the cabinet mounting hardware, if necessary.

APPENDIX

Siren Command Definitions

Command	Function
00H Clear	Clears any event in progress.
01H Wail	Tone Warning.
02H Attack	Tone Warning.
03H Alert	Tone Warning.
04H Public Address	Live Public Address.
05H Air-Horn	Tone Warning.
06H Hi-Lo	Tone Warning.
07H Whoop	Tone Warning.
08H Wail-2 (noon test)	Tone Warning, short tone.
09H North	Positioning command to North.
0AH East	Positioning command to East.
0BH South	Positioning command to South.
0CH West	Positioning command to West.
0DH Clockwise	Positioning command to increment 45° clockwise.
0EH Counter clockwise	Positioning command to increment 45° counter-clockwise.
0FH Silent test	Initiates the diagnostic Silent Test, producing a Status response.
10H Clear	Clears any event in progress.
11H Message 13	Initiates digital voice message 13, for an RSDVM module.
12H Message 14	Initiates digital voice message 14, for an RSDVM module.
13H Message 15	Initiates digital voice message 15, for an RSDVM module.
14H Message 16	Initiates digital voice message 16, for an RSDVM module.
15H Rotor position	Rotor/speaker position request.
16H Counter	Tone activation software counter request.
17H Clear counter	Clears the software tone activation counter to zero.
18H Arm system	Arms the Instant Status response.
19H Dis-arm system	Disables the Instant Status response.
1AH Siren on	Enables the tone generator and digital voice.
1BH Siren off	Disables the tone generator, digital voice is active.
1CH Signal/Noise Req.	Executes the Signal to Noise check in a Remote Siren.
1DH Signal/Noise Status	Signal to Noise reading request.
1EH Test Clear	Clears LEDs
1FH Status Request	Retrieves the Status byte.
20H Clear	Clears any event in progress.
21H Battery/AC	Requests battery voltage and AC voltage measurements.
22H Battery/Temperature	Requests battery voltage and cabinet temp. measurements.
23H Instant Status	Get real time (instant) status of Remote Siren Station.
24H Transmit Off	Disables the transmit repeat feature during Instant Status.
25H Strobe Test	StrobeNode only. 5 to 6 flash test period.
26H not used	
27H Wind Shift	Greatest directional shift, on a sliding 10 minute window.
28H Reset Wind & Temp.	Resets the wind and temperature values.
29H Reset Rainfall	Resets the rainfall value.
2AH Weather	Requests outside temperature, wind direction, wind speed, and rainfall.
2BH Temperature	Requests cabinet temperature, outside temperature, low peak, and high peak (peak values since last reset).
2CH Wind	Requests wind direction, speed, and peak (peak value since last reset).
2DH Rainfall	Requests total rainfall since last reset.
2EH Humidity	Requests the humidity reading.

2FH Barometer Requests the barometric pressure.

continued.....

30H Clear	Clears any event in progress.
31H Message 1	Initiates digital voice message 1, for an RSDVM module.
32H Message 2	Initiates digital voice message 2, for an RSDVM module.
33H Message 3	Initiates digital voice message 3, for an RSDVM module.
34H Message 4	Initiates digital voice message 4, for an RSDVM module.
35H Message 5	Initiates digital voice message 5, for an RSDVM module.
36H Message 6	Initiates digital voice message 6, for an RSDVM module.
37H Message 7	Initiates digital voice message 7, for an RSDVM module.
38H Message 8	Initiates digital voice message 8, for an RSDVM module.
39H Strobe On	Activates the Strobe Light
3AH Strobe Off	De-activates the Strobe Light
3BH Message 9	Initiates digital voice message 9, for an RSDVM module.
3CH Message 10	Initiates digital voice message 10, for an RSDVM module.
3DH Message 11	Initiates digital voice message 11, for an RSDVM module.
3EH Message 12	Initiates digital voice message 12, for an RSDVM module.
3FH Active Status	Requests multiple system status parameters

NOTES:

Commands 09 to 0F are only for rotating sirens, such as the WPS-4000 Series.
Commands 1C and 1D apply to factory installed radio transceiver systems only.
Command 27 to 2F to be used only with a factory supplied weather station. (No longer sold)
Commands 39 and 3A used only with a factory supplied strobe light or StrobeNode.
Command 3F, Moscad use only.

SIREN COMMAND RESPONSE STRUCTURE

Group 0

CMD	Function	CMD Response	Status 1	Status 2
00H	Clear	---	----	----
01H	Wail	0FH (note 1)	Status byte	DC volts
02H	Attack	0FH (note 1)	Status byte	DC volts
03H	Alert	0FH (note 1)	Status byte	DC volts
04H	Public Add.	---	----	----
05H	Air Horn	0FH (note 1)	Status byte	DC volts
06H	Hi-Lo	0FH (note 1)	Status byte	DC volts
07H	Whoop	0FH (note 1)	Status byte	DC volts
08H	Noon Test	0FH (note 1)	Status byte	DC volts
09H	North	---	----	----
0AH	East	---	----	----
0BH	South	---	----	----
0CH	West	---	----	----
0DH	Clockwise	---	----	----
0EH	Counter CW	---	----	----
0FH	Si-Test	1FH (note 1)	Status byte	DC volts

Group 1

CMD	Function	CMD Response	Status 1	Status 2
10H	Clear	---	----	----
11H	Message 13	---	----	----
12H	Message 14	---	----	----
13H	Message 15	---	----	----
14H	Message 16	---	----	----
15H	Rotor pos.	15H (note 1)	Rotor position	----
16H	Counter	16H (note 1)	Counter value	----
17H	Counter clear	16H (note 1)	Counter value	----
18H	Arm	1FH (note 1)	Status byte	DC volts
19H	Dis-arm	1FH (note 1)	Status byte	DC volts
1AH	Siren on	1FH (note 1)	Status byte	DC volts
1BH	Siren off	1FH (note 1)	Status byte	DC volts
1CH	S/N Req	1DH	Noise, no tone	Noise, with tone
1DH	S/N Stat	1DH	Noise, no tone	Noise, with tone
1EH	Test clear	---	----	----
1FH	Status req.	1FH	Status byte	DC volts

continued.....

Group 2

CMD	Function	Response	Status 1	Status 2	Status 3	Status 4
20H	Clear	---	----	----	----	----
21H	Battery/AC	21H (note 1)	Batt DC volts	AC volts	----	----
22H	Batt./Temp.	22H (note 1)	Batt DC volts	Cabinet temp	----	----
23H	Instant Status	23H	Instant Stat	DC volts	----	----
24H	Transmit off	---	----	----	----	----
25H	Strobe Test	---	----	----	----	----
26H	not used	---	----	----	----	----
27H	Wind shift	27H (note 1)	Direction	Time	Speed	Time
28H	Reset wind & temperature	---	----	----	----	----
29H	Reset rainfall	---	----	----	----	----
2AH	Weather	2AH (note 1)	Temperature	Direction	Speed	Rain
2BH	Temperature	2BH (note 1)	Cabinet	Outside	Low	High
2CH	Wind	2CH (note 1)	Direction	Speed	Peak	----
2DH	Rainfall	2DH (note 1)	Tenths	Inches	----	----
2EH	Humidity	2EH (note 1)	Percent	----	----	----
2FH	Barometer	2FH (note 1)	Tenths	Inches	----	----

Group 3

CMD	Function	Response	Status 1	Status 2	Status 3	Status 4
30H	Clear	---	----	----	----	----
31H	Message 1	---	----	----	----	----
32H	Message 2	---	----	----	----	----
33H	Message 3	---	----	----	----	----
34H	Message 4	---	----	----	----	----
35H	Message 5	---	----	----	----	----
36H	Message 6	---	----	----	----	----
37H	Message 7	---	----	----	----	----
38H	Message 8	---	----	----	----	----
39H	Strobe On	---	----	----	----	----
3AH	Strobe Off	---	----	----	----	----
3BH	Message 9	---	----	----	----	----
3CH	Message 10	---	----	----	----	----
3DH	Message 11	---	----	----	----	----
3EH	Message 12	---	----	----	----	----
3FH	Active Status	3FH	Active Cmd	AC Volts	DC Volts	Status

Note 1 - No response if the Immediate Response (SW 7 on Dip Switch 1) on the Remote Siren Station electronic controller is in the disable position. Also, the tone run-time must be greater than 6 seconds for a Status Response.

REMOTE SIREN RESPONSE DEFINITIONS

Status Byte Breakdown

Bit 0 = Full	1 = All amps/drivers pass, 0 = 1 or more amps/drivers fail.
Bit 1 = Partial	1 = 1 or more amps/drivers pass, 0 = all amps/drivers fail.
Bit 2 = Rotor	1 = Rotor incremented, 0 = rotor failure.
Bit 3 = Stored AC	1 = AC voltage on during tone, 0 = AC voltage off during tone.
Bit 4 = Siren On	1 = Tone generator active, 0 = tone generator inactive.
Bit 5 = System Armed	1 = Instant Status response is active, 0 = Instant Status inactive.
Bit 6 = System Power Up	1 = System power up, AC on, DC good, 0 = system power down, AC off or low DC.
Bit 7 = Dynamic AC	1 = AC volts on, 0 = AC volts off.

Voltage Definitions

DC volts = 0 to 35 volts, 0 to 255 decimal, 00 to FF Hex.
 AC volts = 0 to 255 volts, 0 to 255 decimal, 00 to FF Hex.

Instant Status Breakdown

The data that is present at the Instant port at the time of any Instant Status response. The Instant Status response can operate in a number of different ways. In its simplest form, an Instant Status response follows an Instant Status command (23H) from a Central Control Station.

An Instant Status response can also be initiated by an action within a Remote Siren Station, if Switch position 6 on Dip Switch 1, on the ESC-864 electronic controller is in the "On" position. Any change in the state of any bit in the Instant Status byte will cause an Instant Status response to occur. In this case, however, Dip Switch 2 on the ESC-864 electronic controller must be understood. Each bit in the Instant Status byte can be disabled by a corresponding switch position on Dip Switch 2. Switch positions on Dip Switch 2 are as follows:

Sw 1	AC voltage	On = active, Off = masked.
Sw 2	Intrusion	On = active, Off = masked.
Sw 3	Strobe	On = active, Off = masked.
Sw 4	General Fault	On = active
Sw 5	not used	
Sw 6	Full	On = active, Off = masked.
Sw 7	Partial	On = active, Off = masked.
Sw 8	Bias	On = active, Off = masked.

For example, if AC voltage fails and Switch position 1, on Dip Switch 2 is "On", then an Instant Status response will occur. Likewise, if AC voltage fails and Switch 1 is "Off", the Instant Status response will not occur. The Instant Status response is transmitted from a Remote Siren Station 3 times, with 15 seconds between transmissions, unless otherwise disabled. The Transmit Off command (24H) will disable the repeat transmissions, if it is issued following the receipt of an Instant Status byte. Typically, Instant Status bytes Full, Partial and Bias are masked off by switches 6, 7, and 8 of Dip Switch 2.

Bit 0 = AC voltage	1 = AC volts on, 0 = AC volts off
Bit 1 = Intrusion	1 = Cabinet intrusion, 0 = No intrusion
Bit 2 = Strobe Error	1 = Strobe error, 0 = No strobe error
Bit 3 = Supervisor Error	1 = Error, 0 = No error
Bit 4 = not used	

Bit 5 = Full	1 = All amps/drivers pass, 0 = 1 or more amps/drivers fail
Bit 6 = Partial	1 = 1 or more amps/drivers pass, 0 = all amps/drivers fail
Bit 7 = Bias	1 = Bias line is good, 0 = Bias line failure

The Active Status command (3FH) response is defined as follows:

Active Command = the command that is currently being processed (00H to 3EH).

AC Voltage = voltage at the charger input, 0 to 255 volts, 0 to 255 Dec, 00 to FF Hex.

DC Voltage = battery voltage, 0 to 35 volts, 0 to 255 Dec, 00 to FF Hex.

Status Byte =

Bit 0 = stored FULL data,	0 = fail, 1 = pass
Bit 1 = stored PARTIAL data,	0 = fail, 1 = pass
Bit 2 = present Tone Gen BIAS state,	0 = inactive, 1 = active
Bit 3 = present Intrusion state,	0 = door closed, 1 = door open
Bit 4 = StrobeNode error,	0 = no error, 1 = error
Bit 5 = stored Rotor data,	0 = stationary, 1 = oscillating
Bit 6 = Supervision error	0 = no error, 1 = error
Bit 7 = not defined	

SIPS SPEAKERNODE CABLE GUIDE

Below is a list of cable types for the different uses found in the SIPS System. The actual cable used by the customer will depend on application, environment, and local codes. The following is **intended as a guide to help the customer achieve the maximum performance at the most economical price for their system.** Other manufacturers may be used.

TYPE OF INSTALLATION	# of PAIRS	WIRE GAUGE	MANUFACTURER PART #
----------------------	------------	------------	---------------------

< 30 Watt Speaker Runs, 0-2000 feet.

General Use	1	18	ALPHA 5062C or BELDEN 8461
-------------	---	----	----------------------------

30 - 100 Watt Speaker Runs, 0-2000 feet.

General Use	1	16	ALPHA 5072C or BELDEN 8471
-------------	---	----	----------------------------

< 30 Watt Speaker Runs, 2000-4000 feet.

General Use	1	16	ALPHA 5072C or BELDEN 8471
-------------	---	----	----------------------------

30 - 100 Watt Speaker Runs, 2000-4000 feet.

General Use	1	14	ALPHA 5442 or BELDEN 8473
-------------	---	----	---------------------------

< 30 Watt Speaker Run* with SpeakerNodes, 0-1500 feet.

General Use	3	18	ALPHA 5033C or BELDEN 8690
-------------	---	----	----------------------------

30 - 100 Watt Speaker Run* with SpeakerNodes, 1500-2500 feet

General Use	3	16	ALPHA 5076C or BELDEN 8628 (7 cond.)
-------------	---	----	--------------------------------------

A speaker run is a cable extending from a SIPS cabinet, from which one or more speakers are attached. The power rating of the run being the sum of all the speakers attached (daisy-chained) to the cable.

The maximum length of wire in a channel is 4000' for Line Level, 2500' for Device Level.

High electrical noise areas may require shielded cable.

All NEC codes or local codes must be followed , when wiring to remote devices. "T" connections should not be used in supervised systems.

SIPS STROBENODE CABLE SELECTION

Below is a list of cable types for the different uses found in the SIPS System. The actual cable used by the customer will depend on application, environment, and local codes. The following is **intended as a guide to help the customer achieve the maximum performance at the most economical price for their system.** Other manufacturers may be used.

TYPE OF INSTALLATION	# of PAIRS	WIRE GAUGE	MANUFACTURER PART #
----------------------	------------	------------	---------------------

SIPS to StrobeNode

General Use	2	18	ALPHA 5062Cor BELDEN 8461
-------------	---	----	---------------------------

StrobeNode to strobe light

General Use	1	14	ALPHA 5442 or BELDEN 8473
-------------	---	----	---------------------------

High electrical noise areas may require shielded cable.

All NEC codes or local codes must be followed, when wiring to remote devices. "T" connections should not be used in supervised systems.

PRODUCT DESCRIPTION

SIPS SpeakerNode

Model # SPKN030 or SPKN100

Doc # 04-0113433-00

Whelen's SIPS (Supervised In-Plant Warning System) can be equipped with an optional speaker node and speaker, for Device Level supervision. The SpeakerNode is an intelligent node, which drives and monitors the attached speaker.

The SpeakerNode is powered by the same 24 volt DC batteries that power the SIPS control cabinet. Therefore, the SpeakerNode continues to operate during an AC power outage, just like the rest of the SIPS.

A SpeakerNode performs two basic functions. It controls the speaker output power level, through a set of jumpers, and it monitors the actual impedance of the speaker voice coil,

checking for any condition that may affect warning capability.

The SpeakerNode communicates back to the SIPS system via a relay contact closure. Every time the SpeakerNode receives an audio signal, from the SIPS control cabinet, it measures the speaker performance. Any failure is instantly reported back.

In a typical SIPS installation, a SI TEST® is processed every 15 minutes, therefore the status of the speaker is updated every 15 minutes. In addition, the audio wiring is constantly checked for shorts or opens.

Two models are available, one for 0 to 30 watts, one for 60 to 100 watts.

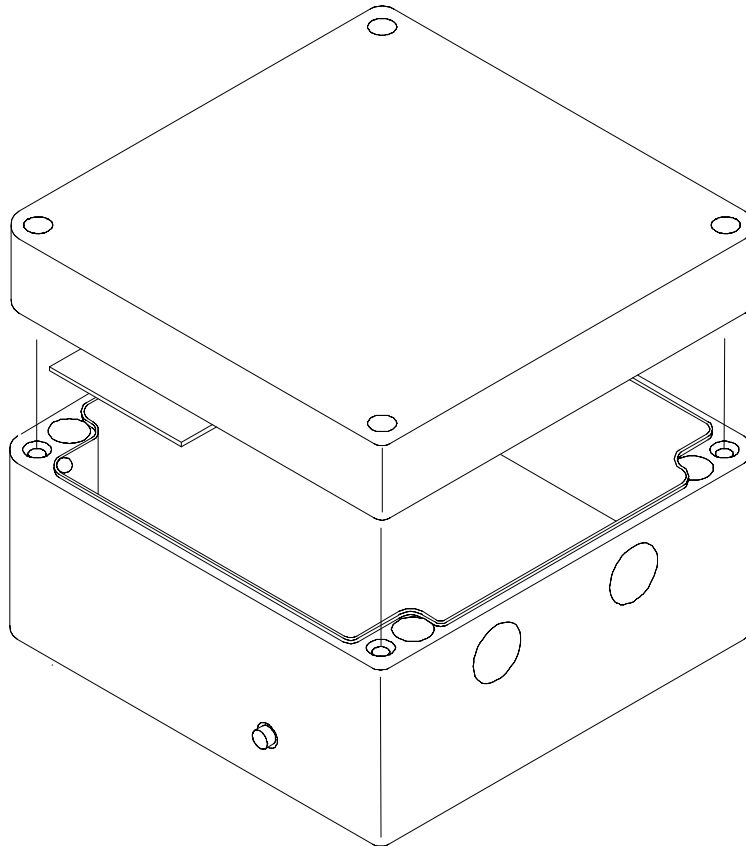

SIPS SpeakerNode

SIPS Input Specifications:

Input Voltage - 15-32 VDC
Input Current - <40mA
Fuse Rating - 1/4 AMP Fast-Blow
Connections - 2 wires for DC power.
 2 wires for Status
 2 wires for Audio

Supported Speakers:

With a SPKN030, up to 30 watts,
WS15, WS15R, WS15REN
WS30

With a SPKN100, 60 to 100 watts,
WS100CH
WSXPL60

Wiring Specifications:

Max. Distance, SIPS to SpeakerNode -
2500' with 16 gauge 2 cond. cable
Max. Distance, SpeakerNode to speaker -
50' with 14 gauge 2 cond. cable

Power Factor Settings:

With a SPKN030, up to 30 watts,

1:1 to 64:1 ratios

With a SPKN100, 60 to 100 watts,

1:1 to 16:1 ratios

Visual Status Indicators:

	RED LED	GREEN LED
ON	----	SPEAKER OK
FLASH	SPEAKER OR NODE FAILURE	NEVER ACTIVATED

Physical Specifications:

Temperature - -35°C to +60°C
Humidity - 0 to 99% (non condensing)
Size - 7.0" (L) x 7.0" (H) x 4.0"(D)

PRODUCT DESCRIPTION

SIPS StrobeNode

Model # STRN1

Doc # 04-0113432-00

Whelen's SIPS (Supervised In-Plant Warning System) can be equipped with an optional strobelight node with strobelight. The StrobeNode is an intelligent node, which controls and monitors the attached strobelight.

The StrobeNode is connected to 120 VAC which is used to charge the internal Gel-Cell batteries. The batteries supply power to the strobelight during activation. The AC voltage level, internal battery charger status and battery voltage is constantly monitored by the StrobeNode. A contact closure signals the SIPS system if a problem occurs. The control connection, to the strobelight, is checked continuously, for shorts or opens.

There are programmable jumpers on the SIPS Supervision Board, inside the SIPS cabinet, that allows the strobelight to turn on and off during specific siren operations. The strobelight can be turned on by a STROBE ON command, siren tone activation, Si-Test® or by a voice command. It can be turned off by a CLEAR command, or a dedicated STROBE OFF command.

The StrobeNode option adds a visually effective strobelight warning to the SIPS system. The 24 VDC strobelight is purchased separately.

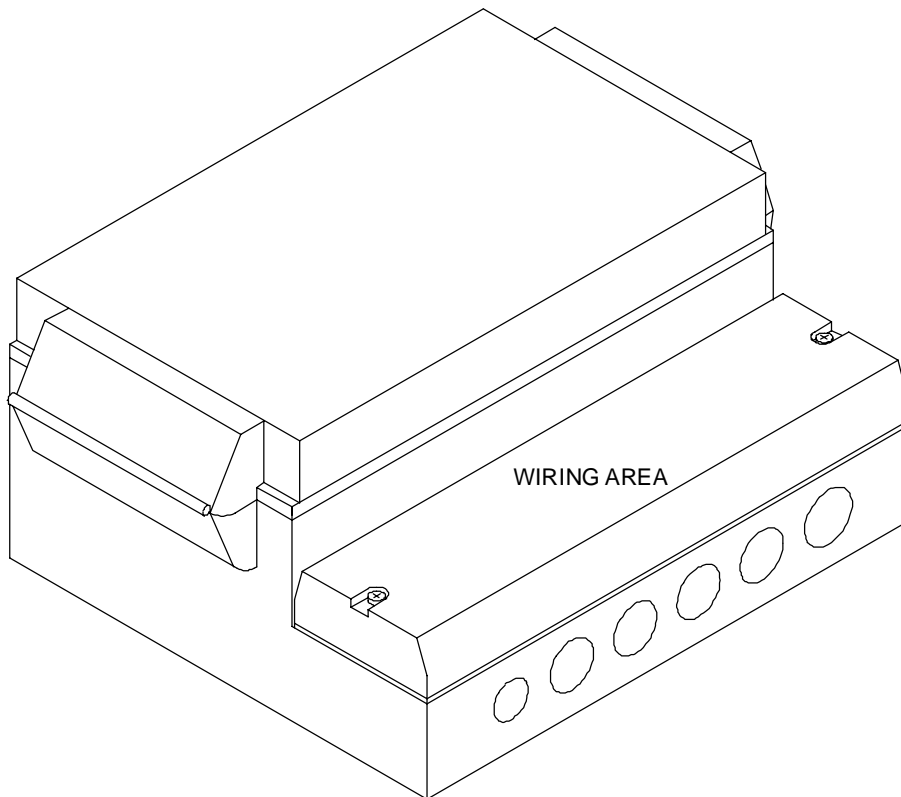

SIPS StrobeNode

PRODUCT SPECIFICATION

SIPS Input Specifications:

Control Voltage - 12 VDC
Input Current - <40mA
Connections - 2 wires for control, polarized.
2 wires for status.

AC Input Specifications:

Input Voltage - 90-132 VAC*
180-264 VAC*
*Jumper Selectable
Fuse Rating - 1/8 AMP Fast-Blow
Input Current - <50mA

Battery Charger Specifications:

Battery Type - (2) 1.2 AHr @ 12 VDC
Sealed, Gel-type
Max Current - 125 mA
Charge Time - 10 Hours maximum
Fuse Rating - 5 AMP Slo-Blow
Charger Type - Temperature Compensated
Constant Current Charge.

Supported Strobe Lights:

Input Voltage - 24VDC
Operating Current - < 2 A @ 26.5 VDC
Run Time - ≈30 min

Strobe Light Maximum Specifications:

DC Voltage - 10-32 VDC
Max. Current Draw - 6 AMPS

Wiring Specifications:

Max. Distance, SIPS to StrobeNode -
2500' with 18 gauge 2 cond. cable
Max. Distance, StrobeNode to strobe light -
50' with 16 gauge 2 cond. cable

SIPS Settings:

Strobe lights can be activated and de-activated by sending a variety of different commands to the SIPS. By setting specific jumpers on the SIPS Supervision Board, the StrobeNodes can be set to respond or ignore these commands. All StrobeNodes follow the same set up.

JP1 (installed) Enables strobe lights by SITEST® command.

JP1 (removed) Default**

JP2 (installed) Enables strobe lights by activation of warning tones.

JP2 (removed) Default**

JP3 (installed) Enables strobe lights by voice commands.

JP3 (removed) Default**

JP4 (installed) Strobe lights are disabled by any CLEAR command to the SIPS.

JP4 (removed) Strobe lights are disabled by a STROBE OFF command only.

**Default condition - Strobe lights are turned on by the STROBE ON command only.

Visual Status Indicators:

	RED LED	GREEN LED	YELLOW LED
OFF	STROBE OK	NO POWER or NODE FAIL	NO AC POWER
ON	STROBE FAILURE		CHARGER OK
FLASH	NO STROBE ATTACHED	NODE OK	CHARGER or BATTERY FAILURE

Physical Specifications:

Temperature - -30°C to +60°C
Humidity - 0 to 99% (non condensing)
Size - 9.5" (l) x 7.5" (h) x 4.6" (d)