

WHELEN[®]

ENGINEERING COMPANY INC.

Route 145, Winthrop Road,

Chester, Connecticut 06412

Phone: (860) 526-9504

Fax: (860) 526-4078

Internet: www.whelen.com

Sales e-mail: autosale@whelen.com

Canadian Sales e-mail: autocan@whelen.com

Customer Service e-mail: custserv@whelen.com

Installation Guide 9E Linear Strobe/Halogen Combination Reflector

Safety First

This document provides all the necessary information to allow your Whelen product to be properly and safely installed. Before beginning the installation and/or operation of your new product, the installation technician and operator must read this manual completely. Important information is contained herein that could prevent serious injury or damage.

- **Proper installation of this product requires the installer to have a good understanding of automotive electronics, systems and procedures.**
- **If mounting this product requires drilling holes, the installer MUST be sure that no vehicle components or other vital parts could be damaged by the drilling process. Check both sides of the mounting surface before drilling begins. Also de-burr any holes and remove any metal shards or remnants. Install grommets into all wire passage holes.**
- **If this product is mounted with tape or Velcro™, clean the mounting surface with a 50/50 mix of isopropyl alcohol and water and dry thoroughly.**
- **Do not install this product or route any wires in the deployment area of your air bag. Equipment mounted or located in the air bag deployment area will damage or reduce the effectiveness of the air bag, or become a projectile that could cause serious personal injury or death. Refer to your vehicle owners manual for the air bag deployment area. The User/Installer assumes full responsibility to determine proper mounting location, based on providing ultimate safety to all passengers inside the vehicle.**
- **For this product to operate at optimum efficiency, a good electrical connection to chassis ground must be made. The recommended procedure requires the product ground wire to be connected directly to the NEGATIVE (-) battery post.**
- **If this product uses a remote device to activate or control this product, make sure that this control is located in an area that allows both the vehicle and the control to be operated safely in any driving condition.**
- **Do not attempt to activate or control this device in a hazardous driving situation.**
- **This product contains either strobe light(s), halogen light(s), high-intensity LEDs or a combination of these lights. Do not stare directly into these lights. Momentary blindness and/or eye damage could result.**
- **Use only soap and water to clean the outer lens. Use of other chemicals could result in premature lens cracking (crazing) and discoloration. Lenses in this condition have significantly reduced effectiveness and should be replaced immediately. Inspect and operate this product regularly to confirm its proper operation and mounting condition. Do not use a pressure washer to clean this product.**
- **It is recommended that these instructions be stored in a safe place and referred to when performing maintenance and/or reinstallation of this product.**
- **FAILURE TO FOLLOW THESE SAFETY PRECAUTIONS AND INSTRUCTIONS COULD RESULT IN DAMAGE TO THE PRODUCT OR VEHICLE AND/OR SERIOUS INJURY TO YOU AND YOUR PASSENGERS!**

Mounting Style #1...

1. Select a mounting location. Make sure that the 9E will not interfere with any existing equipment. Be aware of any and all items on the opposite side of the mounting surface to prevent any possible damage to existing components.
2. Using the dimensions shown on page 2, carefully remove the area of the mounting surface where the reflector will be installed. **Do not remove the mounting surface area where the mounting holes are to be drilled!**
3. Using a drill bit sized for a #10 sheet metal screw (and the thickness of the mounting surface), drill the mounting holes as shown on Page 2.
4. Route the cable assembly through the wiring hole towards the necessary power supply. Be sure that both ring terminals are grounded to the vehicle chassis ground.
5. Now pass the cable through the mounting components as shown. Plug the 9E strobe and (if present) halogen lights into the cable and plug the cable into the power supply. Test operation of the 9E before securing it to the vehicle.

6. Position the 9E components onto the mounting surface and secure to the vehicle using four #10 x 1" (#10 x 1.25" for use with flange mount) sheet metal screws.
7. Position the lens onto the reflector and secure with the supplied #10 x 5/8" lens screw.

Mounting style #2...

1. Same as step 1 of Style #1.
2. Using the dimensions shown on page 3, carefully remove the area of the mounting surface where the reflector will be installed. **Note: Mounting style #2 is designed to use Fastex® grommets (customer supplied) to secure the 9E to its mounting surface.**
3. Same as step 4 & 5 of style #1.
4. Same as step 6 of style #1 except the grommets must be inserted into the areas indicated on page 3.
5. Same as step 7 of style #1.

IMPORTANT: The outer surfaces of this product may be cleaned with mild soap and water. Use of any other chemicals may void product warranty. Do not use a pressure washer.

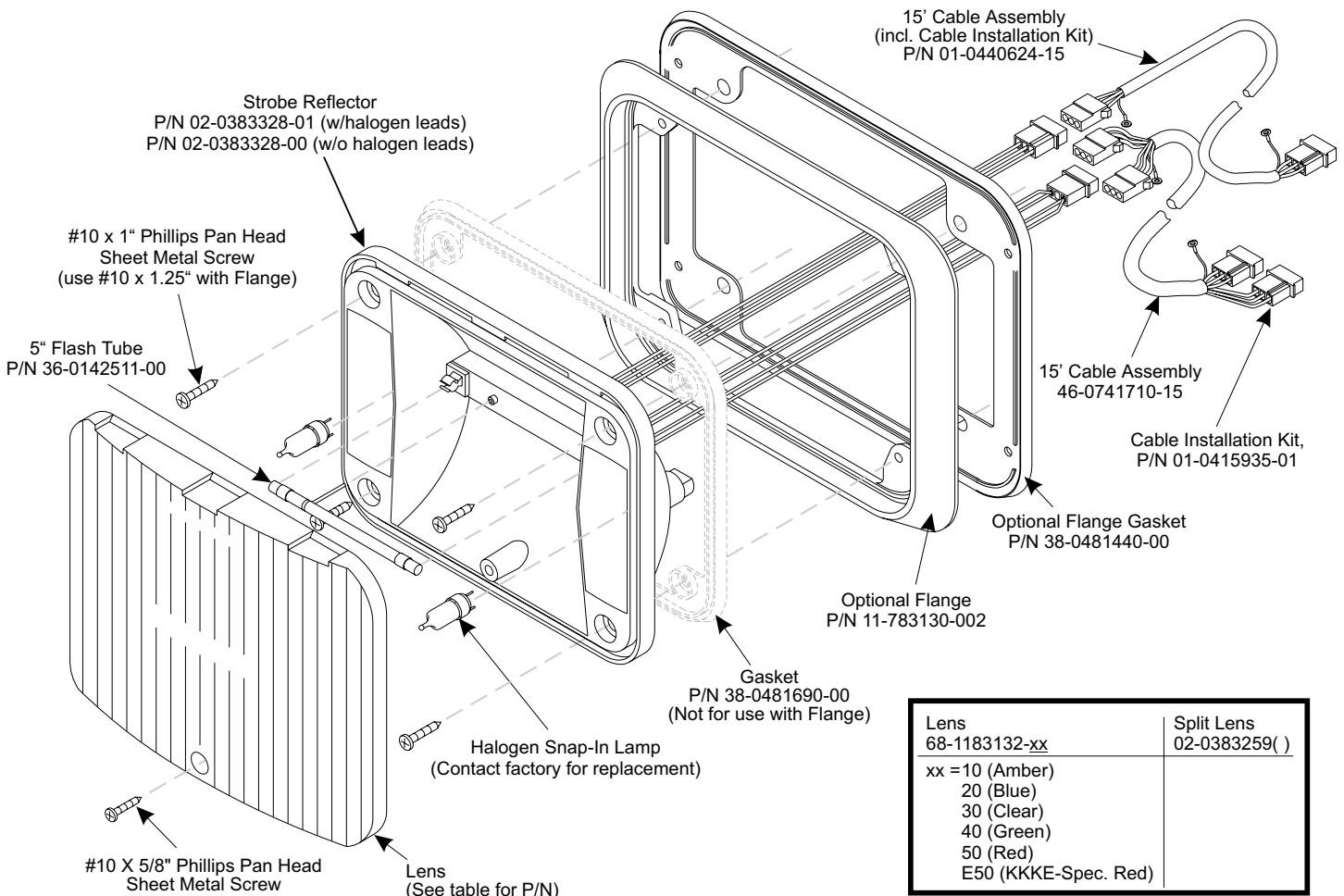

Lens	Split Lens
68-1183132-xx	02-0383259()
xx = 10 (Amber)	
20 (Blue)	
30 (Clear)	
40 (Green)	
50 (Red)	
E50 (KKKE-Spec. Red)	

Mounting Style #1

Note: The dimensions shown in this illustration are shown to the third decimal place. Although the tools capable of cutting this opening prevent this degree of accuracy, it is absolutely necessary to try and stay as close to these dimensions as possible.

Units: Inches
Scale = NONE

IMPORTANT NOTE!!
The template(s) included with this manual
MAY NOT BE TO SCALE.
Before drilling, *CONFIRM ALL DIMENSIONS.*

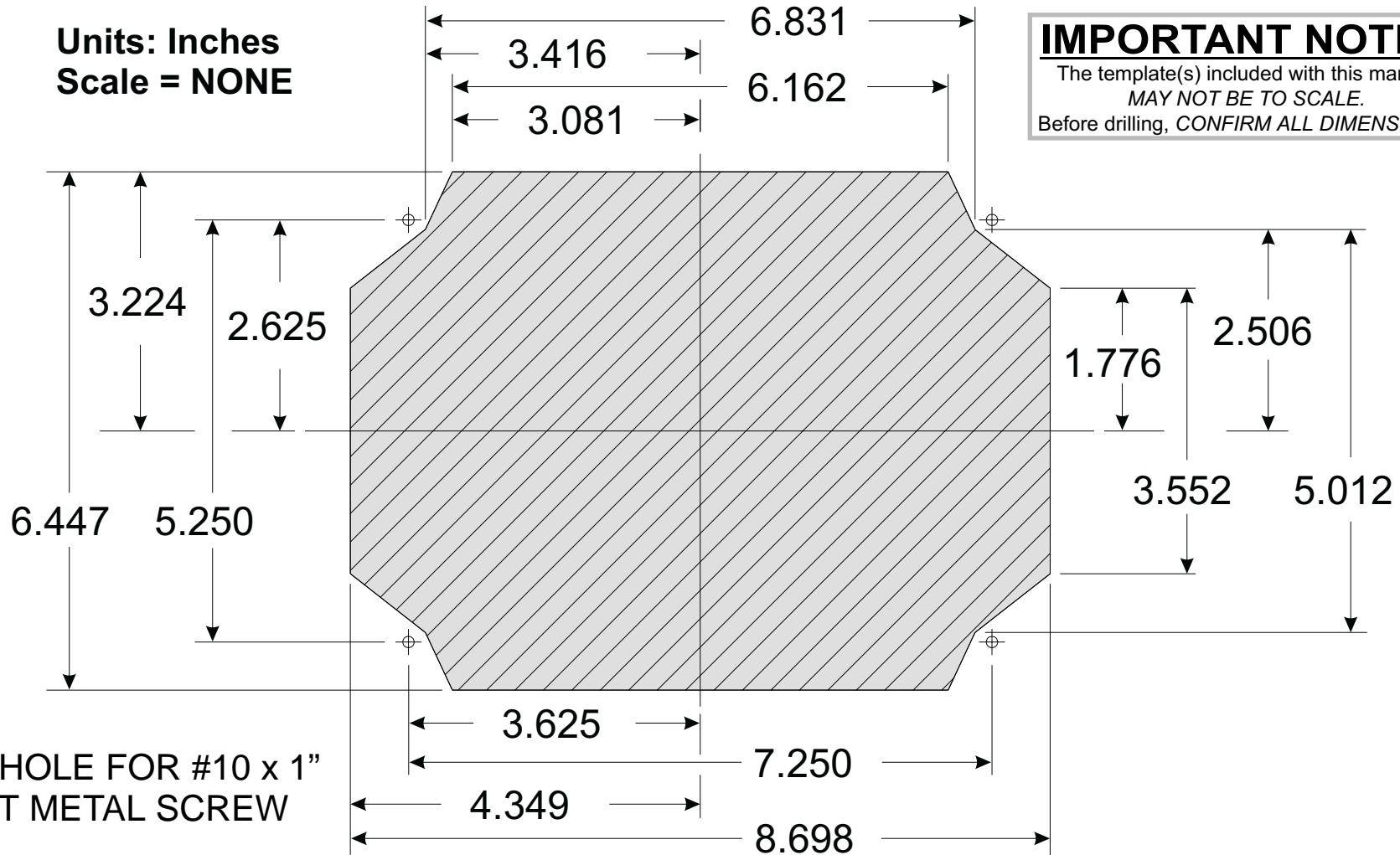

Mounting Style #2

Note: The dimensions shown in this illustration are shown to the third decimal place. Although the tools capable of cutting this opening prevent this degree of accuracy, it is absolutely necessary to try and stay as close to these dimensions as possible.

Units: Inches
Scale = NONE

**Optional Mounting
Template Using
Customer Supplied
Fastex® Grommets**

Page 4

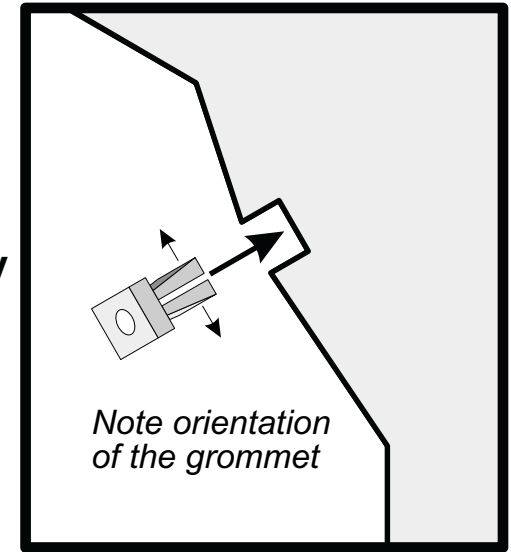
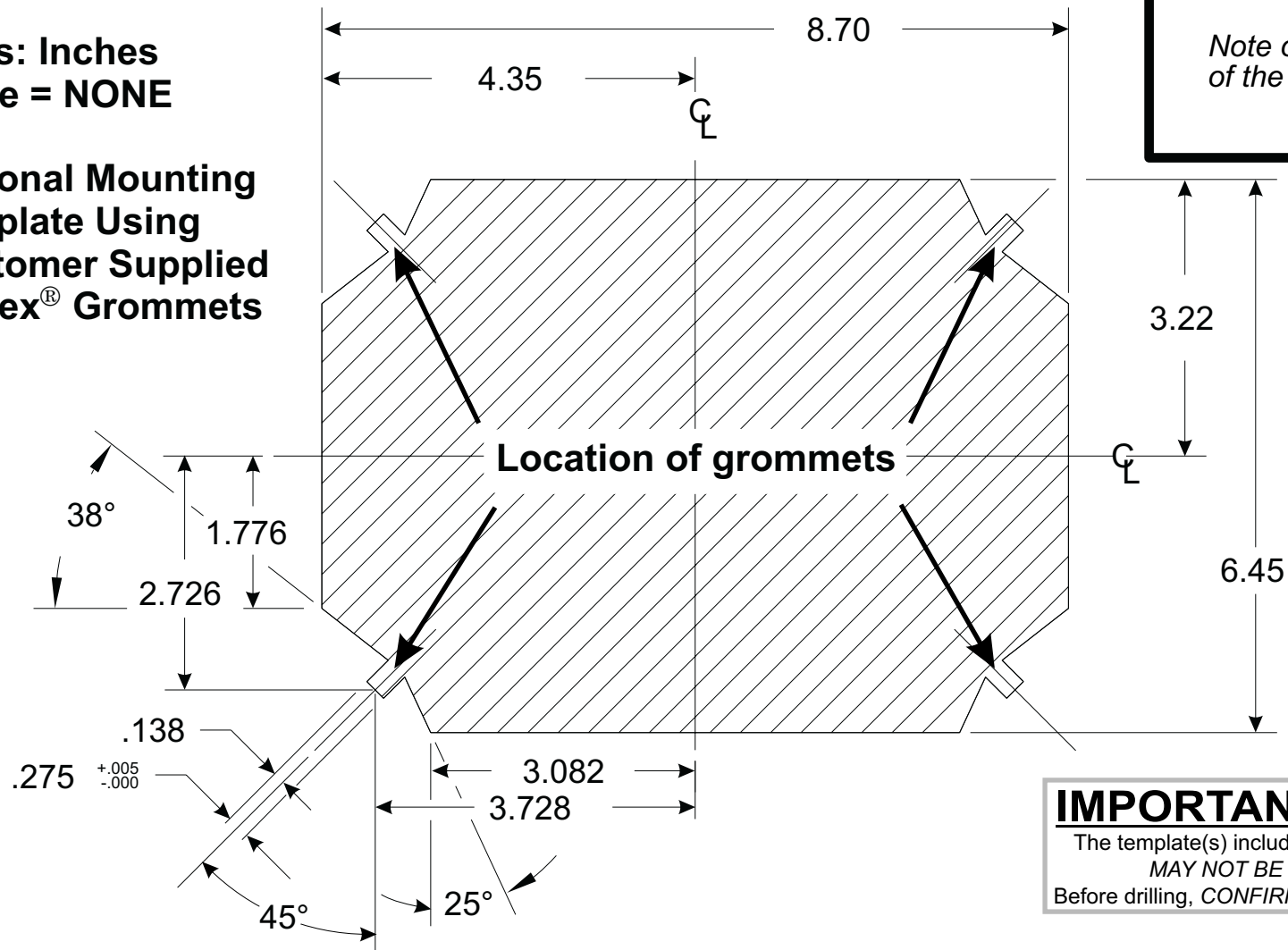

IMPORTANT NOTE!!
The template(s) included with this manual
MAY NOT BE TO SCALE.
Before drilling, CONFIRM ALL DIMENSIONS.