

# WHELEN<sup>®</sup>

ENGINEERING COMPANY INC.

Route 145, Winthrop Road,  
 Chester, Connecticut 06412  
 Phone: (860) 526-9504  
 Fax: (860) 526-4078  
 Internet: [www.whelen.com](http://www.whelen.com)  
 Sales e-mail: [autosale@whelen.com](mailto:autosale@whelen.com)  
 Canadian Sales e-mail: [autocan@whelen.com](mailto:autocan@whelen.com)  
 Customer Service e-mail: [custserv@whelen.com](mailto:custserv@whelen.com)

## Installation Guide: Flange Mount Adaptor Kits 64, 73 & 97-series Lightheads

### INSTALLATION:

**Note:** All of the components illustrated are for the 97-series. They are shown for reference only. The procedures outlined herein are generic and are also for use in the 64- & 73-series.

1. Remove the existing lighthead from the mounting surface and save the hardware used to secure it.
2. Position the flange adapter brackets onto the mounting surface as shown. Secure these adaptors to the mounting surface using the hardware saved in the previous step.
3. Now position the flange gasket and flange onto the mounting surface. Be sure to plug the lamp harness plug into the lamp plug coming from the back of the reflector before proceeding.
4. Mount the lens onto the flange and secure using the phillips pan head sheet metal screws.

**Note:** The 97 series lighthead takes a #10 X 3/4" PPHSMS and the 64 & 73 series lightheads take a #6 X 3/4" PPHSMS.

**IMPORTANT:** The outer surfaces of this product may be cleaned with mild soap and water. Use of any other chemicals may void the product warranty. Do not use a pressure washer.

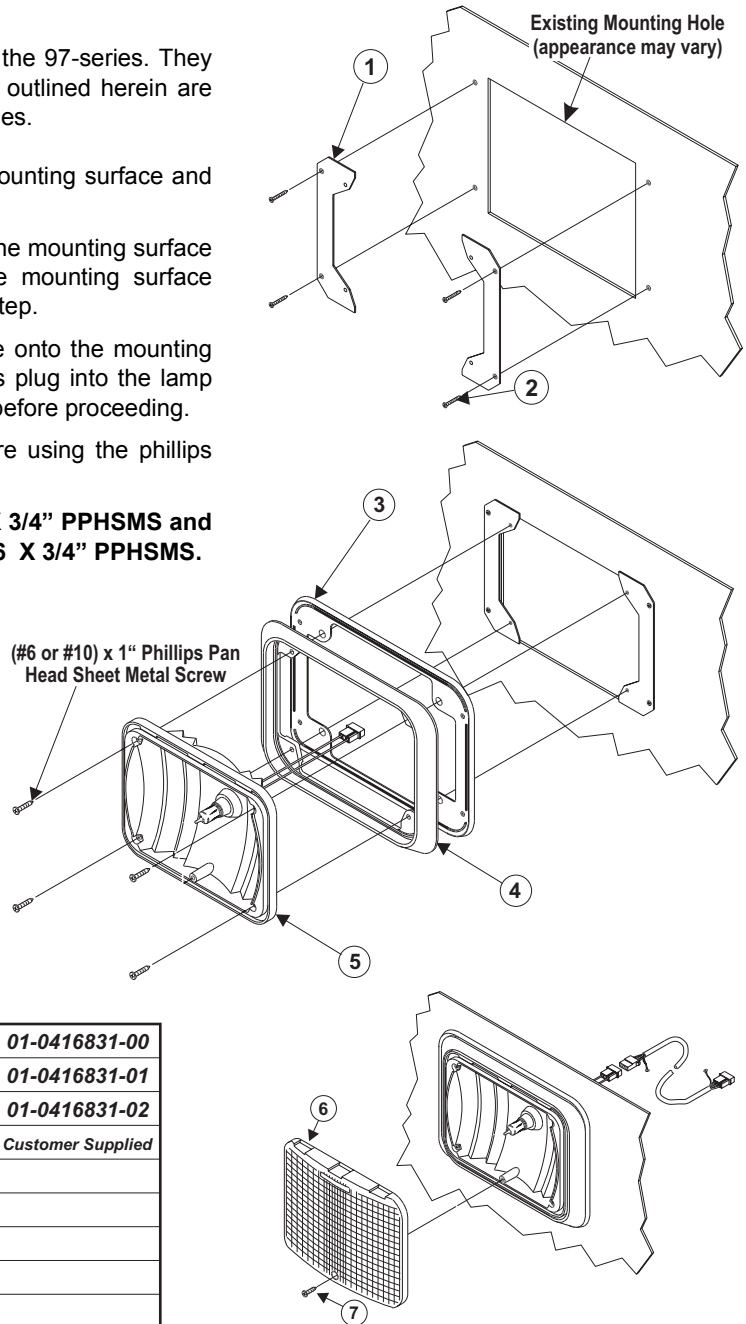

1	64-series Adapter Bracket Kit	01-0416831-00
1	73-series Adapter Bracket Kit	01-0416831-01
1	97-series Adapter Bracket Kit	01-0416831-02
2	(#6 or #10) x 1" Philips Sheet Metal Screw	Customer Supplied
3	Gasket (for Flange or Flanged Reflectors)	
4	Flange	
5	Reflector	
6	Lens	
7	#10 x 3/4" Lens Screw(s)	