

WHELEN[®]

ENGINEERING COMPANY INC.

51 Winthrop Road
 Chester, Connecticut 06412-0684
 Phone: (860) 526-9504
 Fax: (860) 526-4078
 Internet: www.whelen.com
 Sales e-mail: autosale@whelen.com
 Canadian Sales e-mail: autocan@whelen.com
 Customer Service e-mail: custserv@whelen.com

Installation Guide: 295HFSA6 Siren/Power Control Center

DANGER! Sirens produces extremely loud emergency warning tones! Exposure to these tones without proper and adequate hearing protection, could cause ear damage and/or hearing loss! The Occupational Safety & Health Administration (www.osha.gov) provides information necessary to determine safe exposure times in Occupational Noise Exposure Section 1910.95. Until you have determined the safe exposure times for your specific application, operators and anyone else in the immediate vicinity should be required to wear an approved hearing protection device. **FAILURE TO FOLLOW THIS RECOMMENDATION COULD CAUSE HEARING LOSS!**

Safety First

This document provides all the necessary information to allow your Whelen product to be properly and safely installed. Before beginning the installation and/or operation of your new product, the installation technician and operator must read this manual completely. Important information is contained herein that could prevent serious injury or damage.

- Proper installation of this product requires the installer to have a good understanding of automotive electronics, systems and procedures.
- If mounting this product requires drilling holes, the installer **MUST** be sure that no vehicle components or other vital parts could be damaged by the drilling process. Check both sides of the mounting surface before drilling begins. Also de-burr any holes and remove any metal shards or remnants. Install grommets into all wire passage holes.
- If this manual states that this product may be mounted with suction cups, magnets, tape or Velcro™, clean the mounting surface with a 50/50 mix of isopropyl alcohol and water and dry thoroughly.
- Do not install this product or route any wires in the deployment area of your air bag. Equipment mounted or located in the air bag deployment area will damage or reduce the effectiveness of the air bag, or become a projectile that could cause serious personal injury or death. Refer to your vehicle owners manual for the air bag deployment area. The User/Installer assumes full responsibility to determine proper mounting location, based on providing ultimate safety to all passengers inside the vehicle.
- For this product to operate at optimum efficiency, a good electrical connection to chassis ground must be made. The recommended procedure requires the product ground wire to be connected directly to the **NEGATIVE (-)** battery post.
- If this product uses a remote device to activate or control this product, make sure this control is located in an area that allows both the vehicle and the control to be operated safely in any driving condition. **DO NOT ATTEMPT TO ACTIVATE OR CONTROL THIS DEVICE IN A HAZARDOUS DRIVING SITUATION.**
- It is recommended that these instructions be stored in a safe place and referred to when performing maintenance and/or reinstallation of this product.
- **FAILURE TO FOLLOW THESE SAFETY PRECAUTIONS AND INSTRUCTIONS COULD RESULT IN DAMAGE TO THE PRODUCT OR VEHICLE AND/OR SERIOUS INJURY TO YOU AND YOUR PASSENGERS!**

**ACTIVATION OF THIS
SIREN MAY DAMAGE
UNPROTECTED EARS!**



**Wear
Protection!**

CAUTION

Loud siren noise can cause hearing damage and/or loss. Refer to OSHA Section 1910.95 prior to putting ANY siren into service!

For warranty information regarding this product, visit www.whelen.com/warranty

WARNING!

DISCONNECTING THE VEHICLE BRAKE LAMP CIRCUIT USING ANY SIRENS WITH RELAY OUTPUTS OR SWITCH CONTROLLERS COULD CAUSE VEHICLE OR PROPERTY DAMAGE, SERIOUS INJURY OR EVEN DEATH.

DISABLING THIS CIRCUIT IS A VIOLATION OF THE FEDERAL MOTOR VEHICLE SAFETY STANDARD FOR THE THIRD BRAKE LIGHT, AS WELL AS REAR BRAKE LIGHTS.

FUNCTIONS THAT BLACK OUT THE REAR BRAKE LIGHTS (SOMETIMES CALLED “BRAKE LIGHT CUT OUT”) MAY INTERFERE WITH THE BRAKE SHIFT LOCK MECHANISM, AND CAUSE THE VEHICLE TO MOVE UNEXPECTEDLY AND DANGEROUSLY.

DISCONNECTING THE BRAKE LIGHTS IN ANY WAY IS AT YOUR OWN RISK AND IS NOT RECOMMENDED BY WHELEN.

READ BEFORE INSTALLING!!!

Do not install this product or route any wires in the deployment area of your airbag. Equipment mounted or located in the airbag deployment area will damage or reduce the effectiveness of the airbag, or become a projectile that could cause serious personal injury or death. Refer to your vehicle owners manual for the air bag deployment area.

The User/Installer assumes full responsibility to determine proper mounting location, based on providing ultimate safety to all passengers inside the vehicle. Whelen Engineering Company assumes no liability or responsibility for determining individual applications or exact installation location criteria.

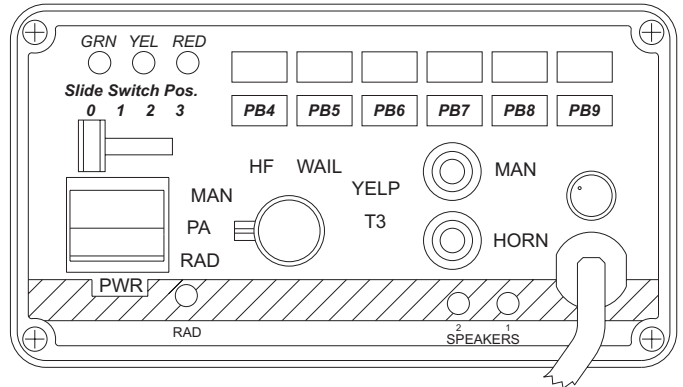

Mounting...

An aftermarket center console is recommended for the mounting location. This not only allows the driver to reach the controls easily, but also keeps the unit safely out of the path of the vehicle's SRS air-bag. Follow the console manufacturer's instructions for mounting information. If a console mounting is not possible, the 295HFSA6 includes a bail strap mounting kit for over or under dash mounting. The following steps will guide you through the installation process.

Wiring the 295HFSA6...

WARNING: All customer supplied wires that connect to the POSITIVE (+) terminal of the battery must be sized to supply at least 125% of the maximum operating current and be fused "at the battery" to carry that load! (See wire recommendations on page 5)

Power Wires (Heavy Gage Wires)

1. Extend the 2 heavy gage RED wires along the vehicle factory wire harness towards the battery. It may be necessary to drill a hole in the firewall. If so, be absolutely sure that there are no components that could be damaged by drilling. After the hole is drilled, insert a grommet to protect the wires.
2. Install a 60 amp fuse block (user supplied) on the ends of each of these wires.

NOTE: Remove the fuse from the fuse block before connecting any wires to the battery!

3. Connect each fuse block wire to the POSITIVE (+) terminal on the battery. There must not be more than 2 feet of wire between the fuse blocks and the battery. As the wire between the fuse and the battery is "unprotected", do not allow this wire to come in contact with any other wires!

Power Wires (Input Connector)

1. Insert the Siren Input Connector into it's port.
2. Connect the 2 RED wires together and extend them toward the battery. Repeat for the 2 BLACK wires.
4. Install a 20 amp fuse block (user supplied) on the end of the RED wire from the siren connector.

NOTE: Remove fuse from fuse block before connecting any wires to the battery!

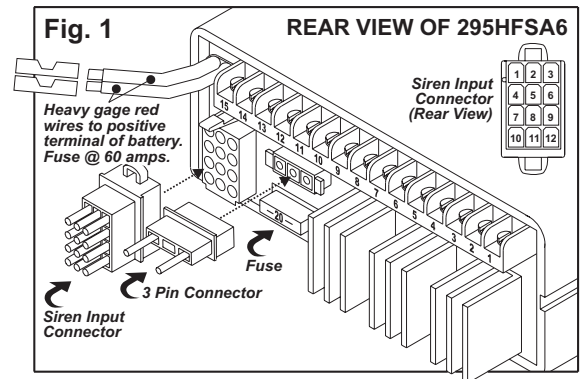

SIREN INPUT CONNECTOR		
PIN	COLOR & GAGE	FUNCTION
1	RED 14GA	+ BATTERY
2	BLACK 14GA	GROUND
3	BLUE 18GA	RADIO
4	RED 14GA	+ BATTERY
5	BLACK 14GA	GROUND
6	BLUE 18GA	RADIO
7	BROWN 16GA	SPEAKER COM
8	ORANGE 16GA	+SPEAKER #2
9	VIOLET 18GA	SIREN SHUTDOWN
10	GRAY 18GA	HORN
11	WHITE 18GA	HORN/RING
12	YELLOW 16GA	+SPEAKER #1

ACTIVATION OF THIS SIREN MAY DAMAGE UNPROTECTED EARS!



CAUTION

Loud siren noise can cause hearing damage and/or loss. Refer to OSHA Section 1910.95 prior to putting ANY siren into service!

5. Connect the fuse block wire to the POSITIVE (+) terminal on the battery. There must not be more than 2 feet of wire between the fuse block and the battery. As the wire between the fuse and the battery is “unprotected”, do not allow this wire to come in contact with any other wires!
6. Connect the BLACK wire to the factory chassis ground typically adjacent to the battery.

Speaker Wires (Yellow, Orange & Brown Wires)

NOTE: This section outlines a two-speaker installation. If a one-speaker installation is used, cut and cap the ORANGE wire, skip steps 3 & 4.

1. Extend the YELLOW, ORANGE and BROWN wires to the vehicle siren speakers and connect as follows.
2. SPEAKER 1 -YELLOW wire to the POSITIVE speaker connection and BROWN to the NEGATIVE speaker connection.
3. SPEAKER 2 - ORANGE wire to the POSITIVE speaker connection.
4. Splice a wire from the NEGATIVE speaker connection on SPEAKER 1 to the NEGATIVE speaker connection on SPEAKER 2.

Horn Relay Wires (White & Grey Wires)

1. Extend the WHITE and GREY wires to the vehicle's horn relay. If possible, follow the factory wire harness to this relay.
2. Locate the wire that connects the vehicle horn to the horn relay. Cut this wire.
3. Connect WHITE wire to wire coming from horn relay.
4. Connect GREY wire to wire coming from horn.

Radio Rebroadcast (Blue Wire (Optional))

NOTE: Radio re-broadcast will NOT work with amplified remote speakers! If your remote speaker is amplified (contains a power amp circuit in the speaker assembly), do not enable the radio re-broadcast feature.

1. Locate the two wires that connect the external speaker to the vehicle's two-way radio.
2. Cut one of these wires and splice one of the BLUE wires into this circuit.
3. Cut the remaining speaker wire and splice the remaining BLUE wire into this circuit.

Siren-Shut-Down (Violet Wire (Optional))

The 295HFSA6 can be configured to cease all siren tones whenever the VIOLET wire is connected to ground through a switch. If this feature is not desired, cut and cap the VIOLET wire. (See Wiring Diagram)

Back Lighting (White/Yellow wire):

Connect this wire to a +12VDC source that is activated with the vehicle's ignition switch (see wiring diagram).

Terminal Operation...

Terminal Specifications

The 295HFSA6 contains 15 screw terminals located in the upper rear panel of the housing. These terminals have been designed to activate components that do not exceed specific load ratings (current draw). It is important that any components connected to these terminals do not exceed the maximum current rating for that terminal. The terminals are rated as follows:

<u>Terminal #'s</u>	<u>Max. Load</u>	<u>Fuse Designation</u>
#1	20 Amps	F1
#2	20 Amps	F2
#s 3, 4 & 5	20 Amps Total	F3
	<i>(Note: These terminals can not be activated individually)</i>	
#6	10 Amps	F4
#7	10 Amps	F5
#8	10 Amps	F6
#9	10 Amps	F7
#11	10 Amps	
#12	10 Amps	F8/F8A
#14	10 Amps	
#15	10 Amps	F9/F9A

(Terminals 11 & 14 are always on unless otherwise noted)

In the default dip switch/fuse configuration the terminal outputs of the 295HFSA6 are enabled as follows:

Slide Switch Positions -

- 0 = Terminals OFF
- 1 = Terminal #1 ON
- 2 = Terminals #1 & 2 ON
- 3 = Terminals #1, 2, 3, 4 & 5 ON

Push-button Switches -

- 4 = Terminal #6 ON
- 5 = Terminal #7 ON
- 6 = Terminal #8 ON
- 7 = Terminal #9 ON
- 8 = Terminal #12 ON / Terminal #11 OFF
- 9 = Terminal #15 ON / Terminal #14 OFF

See the "Custom Dip Switch Configurations" section for information on changing default terminal control

Custom Dip Switch Configurations (Bank 1):

Slide Switch Functionality

In the default configuration the slide switch controls terminals 1 thru 5 (see the Terminal Specifications section for details). This configuration can be altered so that any combination of these five terminals may be active or inactive in any of the 3 functioning slide switch positions. The slide switch configurations are controlled by a dip switch bank which is located on the top circuit board. Access is gained by removing 4 Torx-head screws located at the 4 corners of the face plate. With these screws removed, slide the chassis housing cover towards the rear of the unit. It is not necessary to slide this cover more than a few inches, as the Dip Switch banks are located behind the control panel.

To help illustrate how to change default slide switch control, the following will outline how configure the slide switch so that in position 2, only terminal 2 is enabled, while position 3 will only enable terminal 3.

SLIDE SWITCH POSITION 1 is controlled by dip switches 1, 2 & 3 on bank 1. Dip switch 1 (which controls Terminal 1) is in the ON position, while dip switch 2 (which controls Terminal 2) & dip switch 3 (which controls Terminals 3, 4 & 5) are in the off position. This means that when the slide switch is in position 1, Terminal 1 alone becomes active.

SLIDE SWITCH POSITION 2 is controlled by dip switches 4, 5 & 6 on bank 1. Dip switch 4 (Terminal 1) is off, dip switch 5 (Terminal 2) is on and dip switch 6 (Terminals 3, 4 & 5) is off. This means that when the slide switch is moved to position #2, Terminal 2 alone is active, while Terminals 1, 3, 4 & 5 are inactive.

SLIDE SWITCH POSITION 3 is controlled by dip switches 7, 8 & 9 on bank 1. Dip switch 7 (Terminal 1) is off, dip switch 8 (Terminal 2) is off and dip switch 9 (Terminals 3, 4 & 5) is on. This means that when the slide switch is moved to position 3, Terminals #3, 4 & 5 are active, while Terminals 1 & 2 are inactive.

Enabling Siren Tones through Slide Switch Position #3: Slide switch position 3 can be configured to automatically activate siren tones, as described in Rotary Switch Operations. If this is not desired, make sure that Dip Switch 1 on Bank 2 is in the OFF position. Please note that siren activation through Slide Switch Position 3 is only available when the power switch is in the ON position.

Custom Dip Switch Configurations (Bank 2):

Push button 9 (a momentary-type switch) has the ability to function in four different modes. These modes are defined by the five-position dip switch (Bank 2).

Mode 1 (default) - In this configuration, the output is activated for as long as push-button 9 is depressed.

Mode 2 - In this configuration, when push-button 9 is pressed, the output is activated for a period of 8 seconds.

Mode 3 - In this configuration, when push-button 9 is pressed, the output is activated. When pressed again, the output is deactivated.

Mode 4 - In this configuration, when push-button 9 is pressed, the output is activated for a period of 400 ms. After 400 ms, the output is de-activated for 400 ms. This cycle will continue until push-button 9 is pressed again.

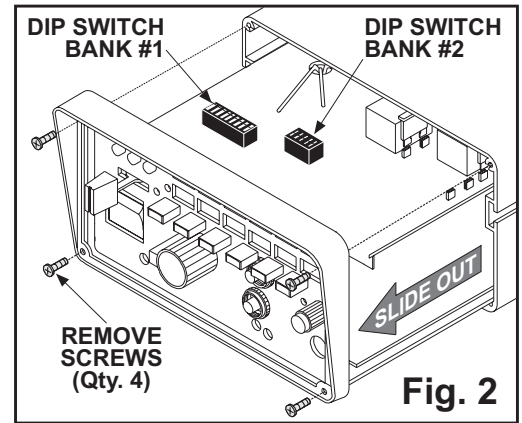

DIP SWITCH CHART / DEFAULT POSITION
The side of the dip switch that is depressed is indicated as black.

Slide Switch	SLIDE SWITCH POSITION #1			SLIDE SWITCH POSITION #2			SLIDE SWITCH POSITION #3		
ON	1	2	3	4	5	6	7	8	9
OFF	1	2	3	4	5	6	7	8	9
Output Terminals Activated	1	2	3	1	2	3	1	2	3
			4			4			4
			5			5			5

DIP SWITCH CHART (Modified for example)
The side of the dip switch that is depressed is indicated as black.

Slide Switch	SLIDE SWITCH POSITION #1			SLIDE SWITCH POSITION #2			SLIDE SWITCH POSITION #3		
ON	1	2	3	4	5	6	7	8	9
OFF	1	2	3	4	5	6	7	8	9
Output Terminals Activated	1	2	3	1	2	3	1	2	3
			4			4			4
			5			5			5

DIP SWITCH CHART / 5 POSITION / BANK 2
Dip Switches are shown below in their default (factory) setting. The side of the dip switch that is depressed is indicated as black.

Slide Switch	AUX ENABLE				NOT USED
ON	1	2	3	4	5
OFF	1	2	3	4	5

MODE 1 (DEFAULT)	MODE 2	MODE 3	MODE 4
1 2 3 4 5	1 2 3 4 5	1 2 3 4 5	1 2 3 4 5
PANEL SWITCH 9 OPERATING MODE: MOMENTARY	PANEL SWITCH 9 OPERATING MODE: 8 SECOND ON TIMER	PANEL SWITCH 9 OPERATING MODE: LATCH ON LATCH OFF	PANEL SWITCH 9 OPERATING MODE: FLASHER (400MS ON & OFF)

Custom Fuse Configurations: Push-buttons 8 & 9 Functionality

Terminals #10 & 13 do not function as output terminals and are not used in the default configuration. By changing the positions of specific fuses, these terminals can be configured to control auxiliary circuits. These auxiliary circuits can not exceed 10 amps each.

Moving Fuse #8 from its default position (F8) to its optional position (F8A) allows push-button 8 to control an auxiliary circuit. Connect *Power In* from the aux. circuit to Terminal #10 and *Load Out* to Terminal #12. Push-button 8 will now open and close this circuit.

Moving Fuse #9 from its default position (F9) to its optional position (F9A) allows push-button 9 to control an auxiliary circuit. Connect *Power In* from the aux. circuit to Terminal #13 and *Load Out* to Terminal #15. Push-button 9 will now open and close this circuit.

Backlighting

Backlighting for the six push buttons may be controlled in one of two manners: In the default (as shipped) mode, the 3 position connector controls the backlighting. The WHITE/YELLOW wire may be connected to a 12VDC source that is activated with the vehicle's ignition switch. For vehicles utilizing a battery disconnect switch an internal jumper may be moved, allowing the backlighting to be controlled by power applied to the number 10 AWG input wires, saving an additional connection.

Diagnostic Indicators

The 295HFSA6 has two diagnostic indicators on the front panel which are used to indicate fault conditions with your siren system. The following table lists the type of fault and the indicators response. If the indicator is on steady while a tone is in use, this implies that there is no fault with the associated speaker output.

Fault Condition and Diagnostic Indicators Response

Under Voltage -

Speaker L.E.D. #2 will be in a double flash mode (2 quick flashes followed by a longer pause) and the siren tones will not operate.

Over Voltage -

Speaker L.E.D. #1 will be in a double flash mode (2 quick flashes followed by a longer pause) and the siren tones will not operate.

Speaker #1 (Short Circuit) -

Speaker L.E.D. #1 will be in a single flash mode (the L.E.D. will be on and off an equal amount of time) and siren tones will not operate.

Speaker #2 (Short Circuit) -

Speaker L.E.D. #2 will be in a single flash mode (the L.E.D. will be on and off an equal amount of time) and siren tones will not operate.

Speaker #1 (Not Connected) -

Speaker L.E.D. #1 will be off, all tones will continue to operate.

Speaker #2 (Not Connected) -

Speaker L.E.D. #2 will be off, all tones will continue to operate.

Fuse F8 moved to F8A position

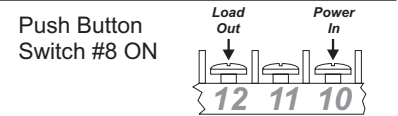
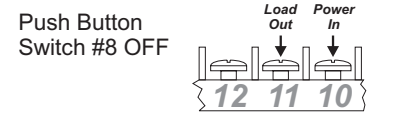

Fuse F9 moved to F9A position

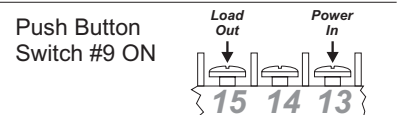

UPPER CIRCUIT BOARD: Fuse, Jumper and Dip Switch Identification

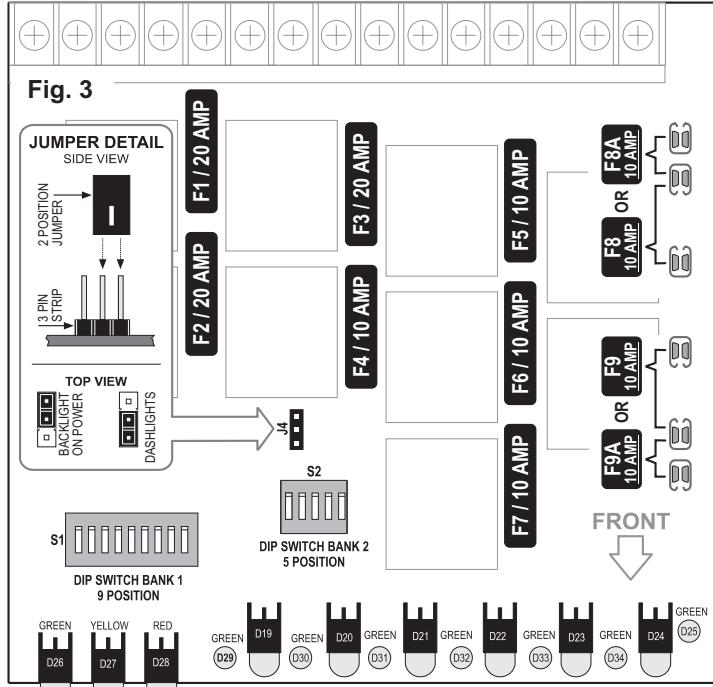

RECOMENDED SIZE for CUSTOMER SUPPLIED WIRES:

Switch Power	
10 AWG	8 FT. MAX
8 AWG	13 FT. MAX
6 AWG	21 FT. MAX
Siren Power & Ground	
12 AWG	18 FT. MAX
10 AWG	30 FT. MAX

Rotary Switch Operations:

RAD (Radio Repeat) - When the rotary knob is in the RAD position, any signal that is received by the vehicle's two-way radio will be simultaneously broadcast over the vehicle's loudspeaker (the 295HFSA6 must be connected to the two-way radio as outlined in this manual).

With the Rotary Switch in this Position:

- Pressing the MAN switch will result in SiTest (See SiTest section)
- Pressing the HORN switch will result in the AIRHORN tone until the HORN switch is released.
- Activating the HORN RING input results in the AIRHORN tone until the HORN RING input is released.
- Activating the SIREN SHUTDOWN input has no effect.
- Activating the AUX ENABLE input has no effect.

PA (Public Address) - When the rotary switch is in this position the siren is in a standby state where no tones have been activated, but is waiting for another action to be taken by the operator. This position is often the best choice when public address is required.

With the Rotary Switch in this Position:

- Pressing the MAN switch will result in a WAIL tone ramping up to the peak frequency and ramping down to a stop at the lowest frequency when the MAN switch is released.
- Pressing the HORN switch will result in the AIRHORN tone until the HORN switch is released.
- Activating the HORN RING input will result in the AIRHORN tone until the HORN RING input is released.
- Activating the SIREN SHUTDOWN input has no effect.
- Activating the AUX ENABLE (Or slide switch position 3, if selected) input will result in a repeating WAIL tone.

WIRING DIAGRAM

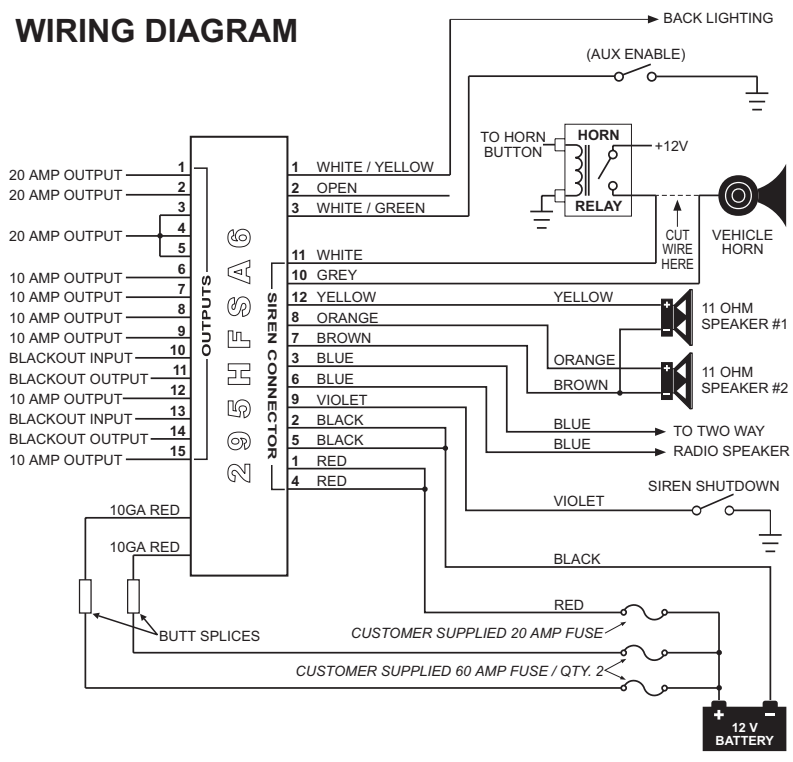

295HFSA6 Specifications

INPUT VOLTAGE	12.5 VDC ±20%
INPUT CURRENT @15 VDC @ 5.5 OHMS .	16 AMPS MAX.
INPUT FUSE	20 AMPS
SPEAKER IMPEDANCE	5.5 OHMS MIN.
OPERATING TEMPERATURE	-30° C. TO +60° C.
STORAGE TEMPERATURE	-40° C. TO +70° C.
HUMIDITY	99% (NON CONDENSING)
OUTPUT VOLTAGE @ 15 VDC @ 11 OHMS	32 V RMS MAX.
OUTPUT POWER @ 15 VDC @ 11 OHMS	105 WATTS MAX.
OUTPUT POWER @ 15 VDC @ 5.5 OHMS	185 WATTS MAX.

MAN (Manual Siren) - When the rotary switch is in this position the siren is in a standby state where no tones have been activated, but is waiting for another action to be taken by the operator. This position is often the best choice when manual operation of the siren is desired.

With the Rotary Switch in this Position:

- Pressing the MAN switch will result in a WAIL tone ramping up to peak frequency and stopping when the MAN switch is released.
- Pressing the HORN switch will result in the AIRHORN tone until the HORN switch is released.
- Activating the HORN RING input will result in a WAIL tone ramping up to the peak frequency and stopping when the HORN RING switch is released.
- Activating the SIREN SHUTDOWN input has no effect.
- Activating the AUX ENABLE input (Or slide switch position 3, if selected) will result in a repeating WAIL tone.

HF (Hands Free Operation) - When the rotary knob is in the HF position, the siren functions of the 295HFSA6 are placed in a stand-by mode. Siren tones are activated by a single tap on the MAN button or a single tap on the vehicle's steering wheel horn ring (if the vehicle's horn has been wired to the HORN RING input). The first tap produces a WAIL tone (a steady rise and fall tone). A second tap produces a yelp tone (a fast rise and fall tone.) A third tap produces a piercer tone (an extremely fast rise and fall tone). The next tap returns the siren to a wail tone and the cycle repeats itself. Two quick successive taps will stop the siren.

With the Rotary Switch in this Position:

- Pressing the MAN switch will result in the HF cycle as described above.
- Pressing the HORN switch will result in the AIRHORN tone until the HORN switch is released.
- Activating the HORN RING input will result in the HF cycle as described above.
- Activating the SIREN SHUTDOWN input will shut the WAIL, YELP and PIERCER tones down. However the HORN and the HORN RING switch will activate an AIRHORN tone and the MAN switch will activate a momentary WAIL tone.
- Activating the AUX ENABLE input (Or slide switch position 3, if selected) will result in the WAIL tone.

WAIL (Wail Tone) - When the rotary knob is in the WAIL position, a steady, rise and fall tone (wail) is produced.

With the Rotary Switch in this Position:

- Pressing the MAN switch will change the siren tone to a yelp pattern. (a fast rise and fall tone)
- Pressing the MAN switch a second time returns it back to a wail tone.

- Pressing the HORN switch will result in the AIRHORN tone until the HORN switch is released.
- Activating the HORN RING input will change the siren tone to a yelp pattern (a fast rise and fall tone). Activating the HORN RING input a second time returns it back to a wail tone.
- Activating the SIREN SHUTDOWN input will shut the WAIL, YELP tones down. However the HORN and the HORN RING switch will activate an AIRHORN tone, and the MAN switch will activate a momentary WAIL tone.
- Activating the AUX ENABLE input has no effect.

YELP (Yelp Tone) - When the rotary knob is in the YELP position, a fast, rise and fall tone is produced.

With the Rotary Switch in this Position:

- Pressing the MAN switch will change the siren tone to a PIERCER pattern (an extremely fast rise and fall tone). Pressing the MAN switch a second time returns it back to a YELP tone.
- Pressing the HORN switch will result in the AIRHORN tone until the HORN switch is released.
- Activating the HORN RING input will change the siren tone to a PIERCER pattern. Activating the HORN RING input a second time returns it back to a YELP tone.
- Activating the SIREN SHUTDOWN input will shut the YELP and PIERCER tones down. However the HORN RING switch will activate an AIRHORN tone and the MAN switch will activate a momentary WAIL tone.
- Activating the AUX ENABLE input has no effect.

T3 (Piercer™ Tone) - When the rotary knob is in the T3 position, an extremely fast, rise and fall tone is produced. May be used for Hi/Lo and auto sequence in some applications.

With the Rotary Switch in this Position:

- Pressing the MAN switch will result in the AIRHORN tone until the MAN switch is released.
- Pressing the horn switch will result in the AIRHORN tone until the HORN switch is released.
- Activating the HORN RING input will result in the AIRHORN tone until the man switch is released.
- Activating the SIREN SHUTDOWN input will shut the PIERCER tone down. However the HORN and the HORN RING switch will activate an AIRHORN tone, and the MAN switch will activate a momentary WAIL tone.
- Activating the AUX ENABLE will have no effect.

Microphone

Whenever the 295HFSA6 is powered on, activating the microphone (pressing the switch on the side of the mic.) will shut down any other siren functions and enable public address operation regardless of the rotary switch position or any other switch or input.

295HFSA6 Siren Operations:

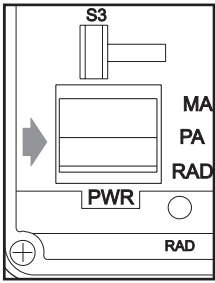

POWER SWITCH

This switch has two positions. Down (Off) & Up (On). When this switch is Off, the unit will not function. When the switch is On, the siren is functional and may be activated at the operator's discretion. **NOTE: If the 295HFSA6 is connected to the vehicle's horn ring circuit, the vehicle horn is disabled when the power switch is in the ON position.**

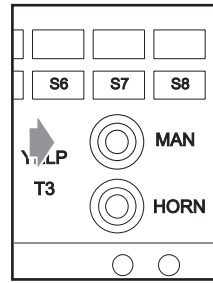

MAN BUTTON

The Manual button generates a variety of tones, depending on what position the rotary knob is in. For further explanation of this button's function, refer to Rotary Switch Operations.

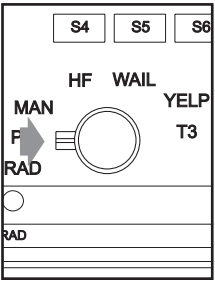

ROTARY SWITCH

The Rotary Knob controls the siren and PA (Public Address) functions of the 295HFSA6. There are 7 positions that may be selected. Each position and its function is outlined under "Rotary Switch Operations".

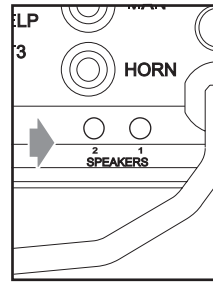

SI-TEST® & DIAGNOSTIC INDICATORS

SI-TEST® is a diagnostic feature of the 295HFSA6 and allows the operator to confirm the proper operation of the siren speakers connected to the unit without activating an audible siren tone. To initiate SI-TEST® cycle, set the rotary knob to the RAD position. Now press and release the MAN button. As the siren is

tested, its diagnostic indicator will turn on steady for about 1.5 seconds if no problems are detected. If the indicator flashes, or does not light at all, a problem with either the siren, speakers, or wiring has been detected. Check the wire connections of the failed speaker and repeat the SI-TEST®. If the speaker fails to test again, have the siren itself inspected by a qualified technician. **NOTE: Installed speakers are tested by generating an ultra-high frequency tone through each speaker. Although these tones are inaudible to humans, be sure that there is nobody within 5 feet of the speakers when SI-TEST® is running.**

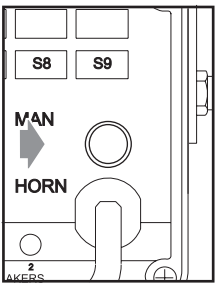

VOLUME KNOB

The Volume Knob controls the volume of Public Address function. Volume is increased by rotating the knob in a clockwise direction. Rotating the volume knob in a counter-clockwise direction decreases the volume produced by these features. The volume knob has no effect on any siren tones produced.

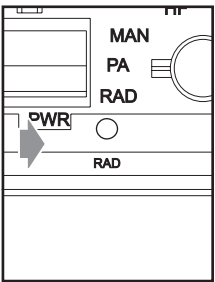

RADIO REPEAT VOLUME

To Adjust the Radio Repeat Levels: Before using the 295HFSA6, the Radio Repeat output volume must be adjusted to satisfactory operating levels. To adjust this level, a small, flat blade screwdriver is needed. Locate the Radio Repeat adjustment port (potentiometer) to the right of the Rotary Knob on the face of the control head. Set the volume level of the vehicle's two-way radio to its normal operating volume. Turn the Rotary Knob on the control head to RAD to activate Radio Repeat. Insert the screwdriver in the Radio Repeat adjustment port and turn in clockwise direction to increase the sound level.

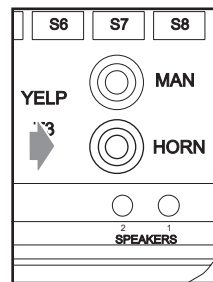

HORN BUTTON

Holding the HORN button on, generates an AIRHORN tone whenever the siren is powered up.