

# WHELEN<sup>®</sup>

ENGINEERING COMPANY INC.

51 Winthrop Road  
Chester, Connecticut 06412-0684  
Phone: (860) 526-9504  
Fax: (860) 526-4078  
Internet: [www.whelen.com](http://www.whelen.com)  
Sales e-mail: [autosale@whelen.com](mailto:autosale@whelen.com)  
Canadian Sales e-mail: [autocan@whelen.com](mailto:autocan@whelen.com)  
Customer Service e-mail: [custserv@whelen.com](mailto:custserv@whelen.com)

## Installation Guide: Centurion™ Lightbar Option Kit KL14SF Corner Strobes

### Safety First

This document provides all the necessary information to allow your Whelen product to be properly and safely installed. Before beginning the installation and/or operation of your new product, the installation technician and operator must read this manual completely. Important information is contained herein that could prevent serious injury or damage.

- Proper installation of this product requires the installer to have a good understanding of automotive electronics, systems and procedures.
- If mounting this product requires drilling holes, the installer **MUST** be sure that no vehicle components or other vital parts could be damaged by the drilling process. Check both sides of the mounting surface before drilling begins. Also de-burr any holes and remove any metal shards or remnants. Install grommets into all wire passage holes.
- If this manual states that this product may be mounted with suction cups, magnets, tape or Velcro®, clean the mounting surface with a 50/50 mix of isopropyl alcohol and water and dry thoroughly.
- Do not install this product or route any wires in the deployment area of your air bag. Equipment mounted or located in the air bag deployment area will damage or reduce the effectiveness of the air bag, or become a projectile that could cause serious personal injury or death. Refer to your vehicle owner's manual for the air bag deployment area. The User/Installer assumes full responsibility to determine proper mounting location, based on providing ultimate safety to all passengers inside the vehicle.
- For this product to operate at optimum efficiency, a good electrical connection to chassis ground must be made. The recommended procedure requires the product ground wire to be connected directly to the **NEGATIVE (-)** battery post.
- If this product uses a remote device to activate or control this product, make sure that this control is located in an area that allows both the vehicle and the control to be operated safely in any driving condition.
- Do not attempt to activate or control this device in a hazardous driving situation.
- This product contains either strobe light(s), halogen light(s), high-intensity LEDs or a combination of these lights. Do not stare directly into these lights. Momentary blindness and/or eye damage could result.
- Use only soap and water to clean the outer lens. Use of other chemicals could result in premature lens cracking (crazing) and discoloration. Lenses in this condition have significantly reduced effectiveness and should be replaced immediately. Inspect and operate this product regularly to confirm its proper operation and mounting condition. Do not use a pressure washer to clean this product.
- It is recommended that these instructions be stored in a safe place and referred to when performing maintenance and/or reinstallation of this product.
- **FAILURE TO FOLLOW THESE SAFETY PRECAUTIONS AND INSTRUCTIONS COULD RESULT IN DAMAGE TO THE PRODUCT OR VEHICLE AND/OR SERIOUS INJURY TO YOU AND YOUR PASSENGERS!**

**For warranty information regarding this product, visit [www.whelen.com/warranty](http://www.whelen.com/warranty)**

### Disassembly of Lightbar:

1. Remove the two Torx head screws that secure end cap to the base and slide the lens sections off the end of the base and remove the dividers so you may gain access to the lightbar base. (Figs. 1 & 2)  
Be sure to note the order in which the lenses were installed on the lightbar.

**IMPORTANT NOTE:** You will notice that the lenses are seated very tightly into the lens divider gaskets to prevent leaks. You will need to insert a screwdriver at each corner (between the black endcap and aluminum base) and gently pry the lens out to break it free from the dividers. Pry each side out just a little at a time, alternating from one side to the other until the lens slides out easily. Before reassembling, apply a very small amount of liquid dish detergent to the sides of the rubber gaskets to help them slide in easier and obtain a better seal.

### Installing the Strobe Power Supply:

Your corner strobes must be mounted on the *far outside corners* of the lightbar, the power supply will mount between two of the "V" mirrors. The power supply bracket will use the same screw holes that the mirror uses.

**NOTE:** You must use the long screws that come with the power supply.

1. Remove the two diamond mirrors by removing their four mounting screws.
2. Take the RPS220 Power Supply (with bracket attached) and place it on the lightbar base extrusion as shown in the illustration below. Place the "V" mirror bases on top of the power supply mounting bracket and secure the mirrors and power supply using the 4 power supply mounting screws.
3. Install the 2 strobes using the 2 mounting screws as shown below. Now you are ready to wire the strobes (see wiring diagram).

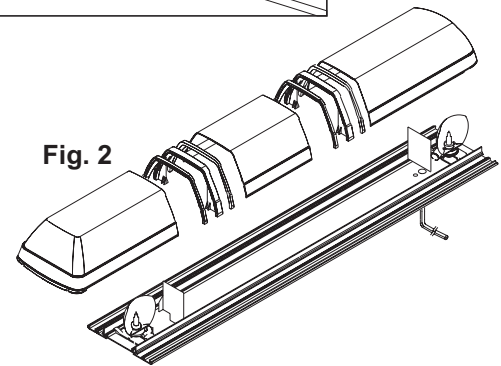
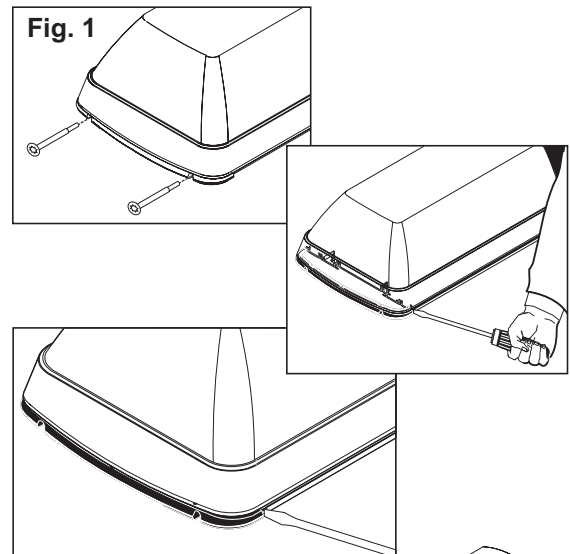

**IMPORTANT:** The outer surfaces of this product may be cleaned with mild soap and water. Use of any other chemicals may void product warranty. Do not use a pressure washer.

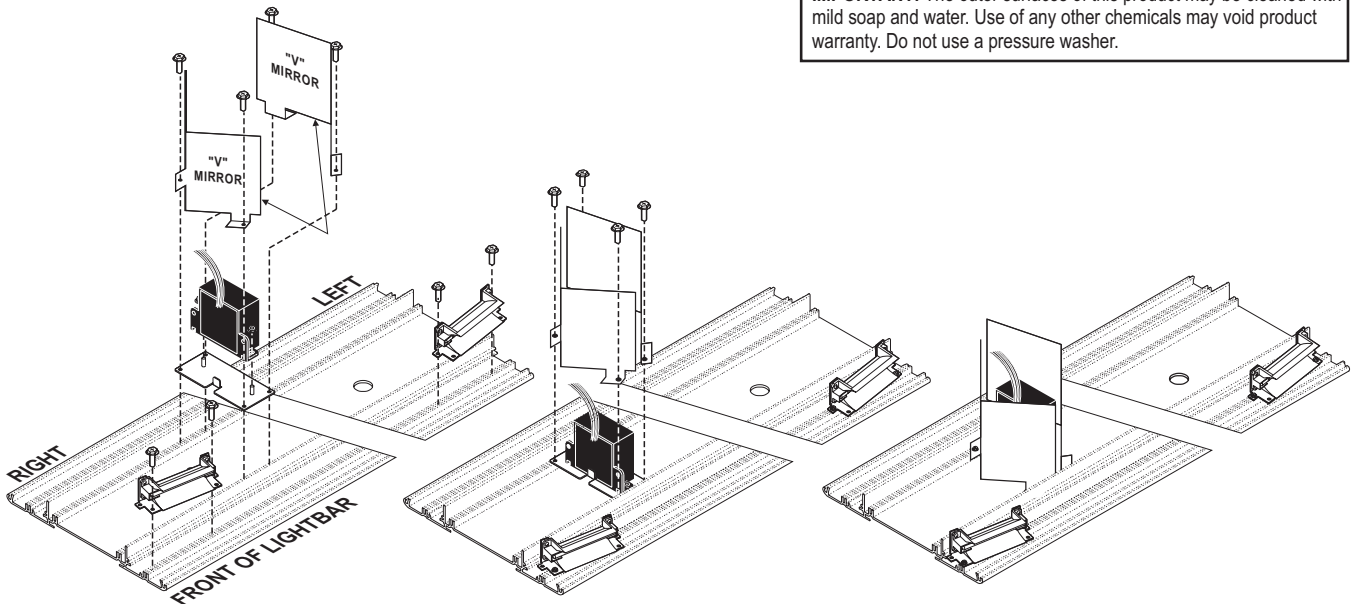

# WIRING DIAGRAM

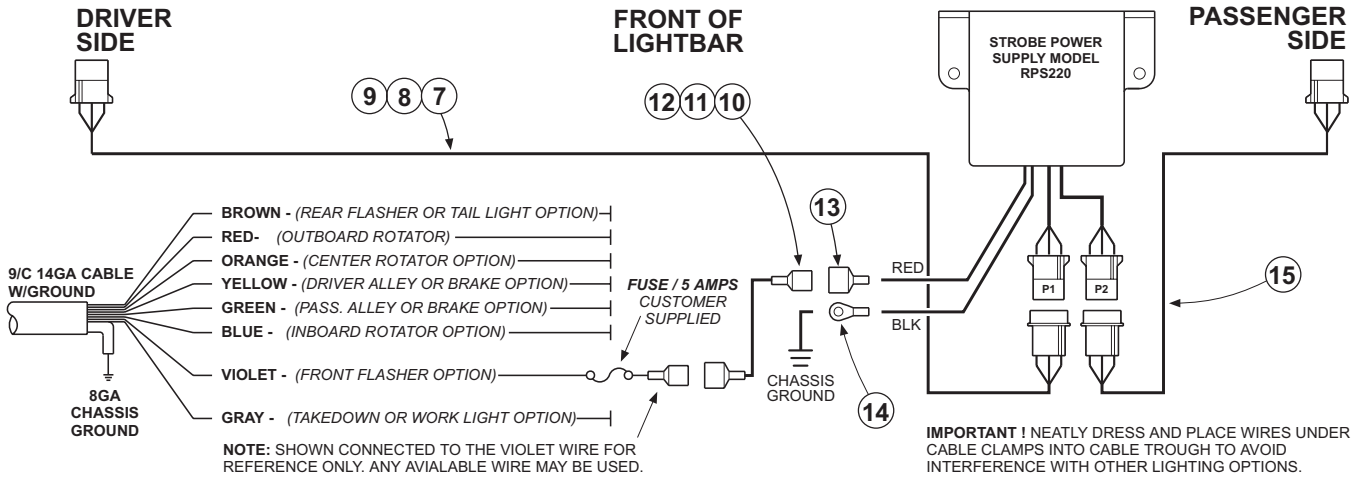

## Wiring:

1. Crimp the GROUND LUG (14) to the BLACK wire of the power supply and secure it to the lightbar base with the supplied screw (6).
2. Crimp a MALE (larger) FASTON CONNECTOR (13) to the RED wire on the power supply.
3. Find the 9" STROBE HARNESS (15) in your parts bag and plug the AMP SOCKET CONNECTOR into the passengers side strobe and the AMP PIN CONNECTOR into the P2 AMP SOCKET CONNECTOR on your power supply as shown.
4. Now take the other LONGER STROBE HARNESS and plug the AMP SOCKET CONNECTOR into the drivers side strobe and the AMP PIN CONNECTOR into the P1 AMP SOCKET CONNECTOR on the power supply. **NOTE:** Wrap and tie any excess wire to keep it out of the way of any other lighting options. Between the "V" mirrors is a good location that will be out of the way.
5. Next find the RED wire coming from the power supply and plug it into the long VIOLET connector (supplied). Plug the other end of the VIOLET connector into the VIOLET wire coming from the lightbar cable. (See *fusing*, above) **NOTE:** Any available wire from the lightbar cable may be used if the VIOLET wire is already in use. Reassemble the lightbar.

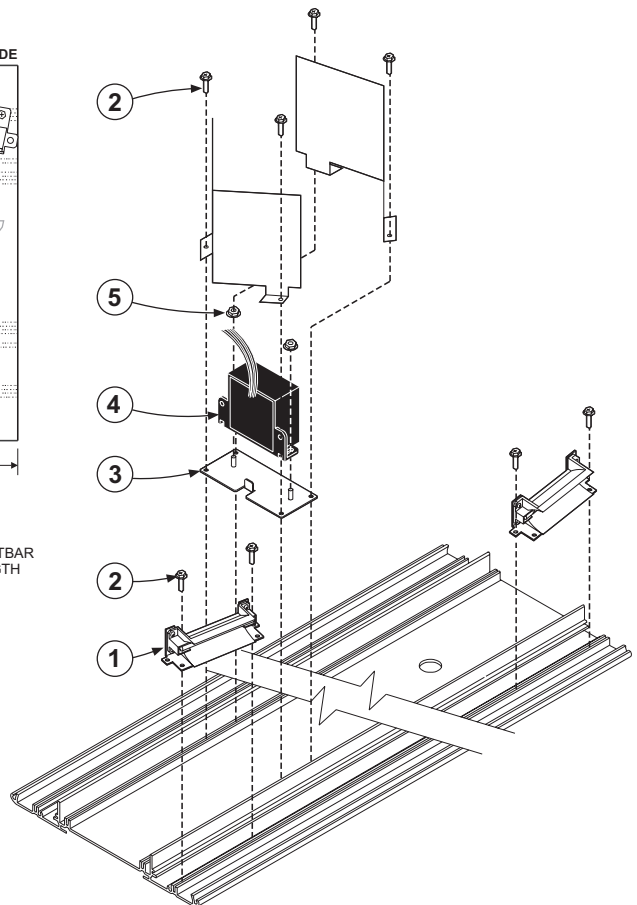
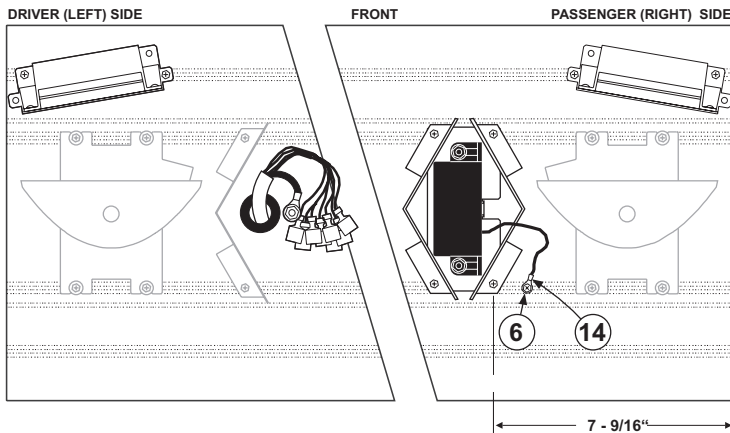

QTY.	ITEM	PART NUMBER	DESCRIPTION
-	-	02-0383314-0	ASSEMBLY / CORNER STROBES & P. SUPPLY
2	1	02-0363042-00	SUB-ASS'Y / 14 SERIES CORNER STROBE
8	2		#8 X 3/8" PHEXWASHERHD SS TYPE B
1	3	07-0242656-000	BRACKET / POWER SUPPLY MOUNT
1	4	01-0668602-00	ASS'Y / "RPS220" STROBE POWER SUPPLY
2	5		#10-24 WHIZ LOCKNUT
1	6		#8 X 1/4" PHEXWASHERHD SS TYPE B
A/R	7	46-0963049-01	ASS'Y / HARNESS- STROBE / 48" - 52" BAR"
A/R	8	46-0963049-02	ASS'Y / HARNESS- STROBE / 60" BAR
A/R	9	46-0963049-03	ASS'Y / HARNESS- STROBE / 72" BAR"
A/R	10	67-1F91877340	WIRE / VIOLET/34" POWER INPUT / 48" - 52" BAR
A/R	11	67-1F91877420	WIRE / VIOLET/42" STROBE INPUT / 60" BAR
A/R	12	67-1F91877540	WIRE / VIOLET / 54" STROBE INPUT / 72" BAR
1	13	25-1240423-05	MALE FASTON 18GA. INS.
1	14	25-2544520-05	#8 RING TERM. 18GA. NON INS.
1	15	46-0963049-00	ASS'Y / HARNESS- STROBE / 9" LG.
3	16	26-0215001-03	TY-RAP / 3" / BLACK

PART NUMBER KEY	
02-0383314-0	LIGHTBAR LENGTH
1 = 48" & 52"	
2 = 60"	
3 = 72"	