

WHELEN[®] ENGINEERING COMPANY INC.

51 Winthrop Road
 Chester, Connecticut 06412-0684
 Phone: (860) 526-9504
 Fax: (860) 526-4078
 Internet: www.whelen.com
 Sales e-mail: autosale@whelen.com
 Canadian Sales e-mail: autocan@whelen.com
 Customer Service e-mail: custserv@whelen.com

Installation Guide: Project-A-Flex[®] Speaker System

DANGER! Sirens produces extremely loud emergency warning tones! Exposure to these tones without proper and adequate hearing protection, could cause ear damage and/or hearing loss! The Occupational Safety & Health Administration (www.osha.gov) provides information necessary to determine safe exposure times in Occupational Noise Exposure Section 1910.95. Until you have determined the safe exposure times for your specific application, operators and anyone else in the immediate vicinity should be required to wear an approved hearing protection device. **FAILURE TO FOLLOW THIS RECOMMENDATION COULD CAUSE HEARING LOSS!**

Safety First

This document provides all the necessary information to allow your Whelen product to be properly and safely installed. Before beginning the installation and/or operation of your new product, the installation technician and operator must read this manual completely. Important information is contained herein that could prevent serious injury or damage.

- Proper installation of this product requires the installer to have a good understanding of automotive electronics, systems and procedures.
- If mounting this product requires drilling holes, the installer **MUST** be sure that no vehicle components or other vital parts could be damaged by the drilling process. Check both sides of the mounting surface before drilling begins. Also de-burr any holes and remove any metal shards or remnants. Install grommets into all wire passage holes.
- If this manual states that this product may be mounted with suction cups, magnets, tape or Velcro[®], clean the mounting surface with a 50/50 mix of isopropyl alcohol and water and dry thoroughly.
- Do not install this product or route any wires in the deployment area of your air bag. Equipment mounted or located in the air bag deployment area will damage or reduce the effectiveness of the air bag, or become a projectile that could cause serious personal injury or death. Refer to your vehicle owner's manual for the air bag deployment area. The User/Installer assumes full responsibility to determine proper mounting location, based on providing ultimate safety to all passengers inside the vehicle.
- For this product to operate at optimum efficiency, a good electrical connection to chassis ground must be made. The recommended procedure requires the product ground wire to be connected directly to the **NEGATIVE (-)** battery post.
- If this product uses a remote device to activate or control this product, make sure this control is located in an area that allows both the vehicle and the control to be operated safely in any driving condition. **DO NOT ATTEMPT TO ACTIVATE OR CONTROL THIS DEVICE IN A HAZARDOUS DRIVING SITUATION.**
- It is recommended that these instructions be stored in a safe place and referred to when performing maintenance and/or reinstallation of this product.
- **FAILURE TO FOLLOW THESE SAFETY PRECAUTIONS AND INSTRUCTIONS COULD RESULT IN DAMAGE TO THE PRODUCT OR VEHICLE AND/OR SERIOUS INJURY TO YOU AND YOUR PASSENGERS!**

ACTIVATION OF THIS SIREN MAY DAMAGE UNPROTECTED EARS!

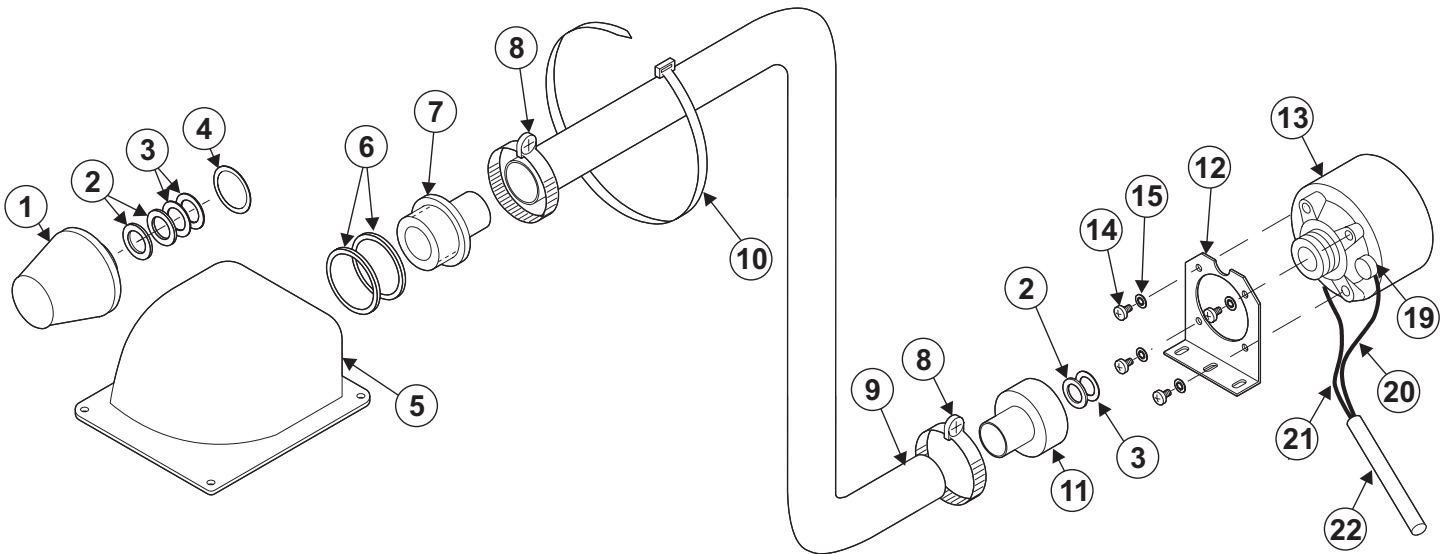


Wear Protection!

CAUTION

Loud siren noise can cause hearing damage and/or loss. Refer to OSHA Section 1910.95 prior to putting ANY siren into service!

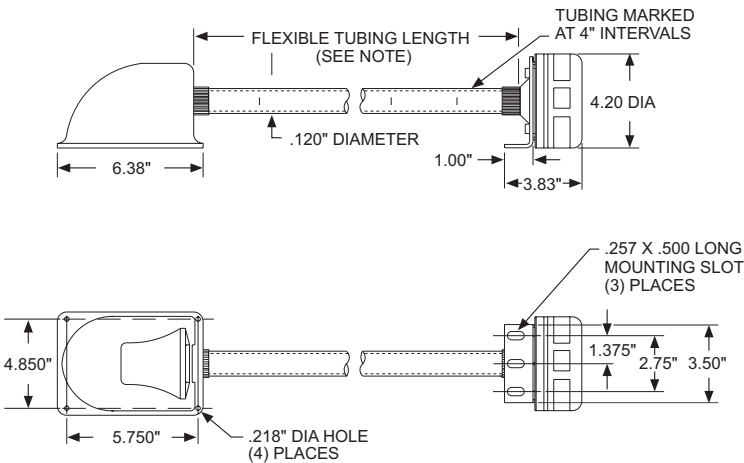
For warranty information regarding this product, visit www.whelen.com/warranty



The Project-A-Flex® siren speaker allows the horn and driver to be installed separately under the hood of even the most compact vehicles. The speaker driver can be mounted on the firewall or the fenderwall virtually any distance from the horn. Through the use of acoustical flexible tubing, the horn can be mounted behind the vehicles grille, under the bumper or any other concealed location that will allow the forward projection of sound. The acoustical flexible tubing not only allows easier installation, but also substantially increases the sound level gain.

QTY.	ITEM	PART NUMBER	DESCRIPTION
		01-0860496-00	PROJECT-A-FLEX™ ASSY
1	1	72-4010291-00	SPEAKER CONE
3	2	38-0220049-00	RUBBER SEAL
3	3	38-0220048-00	FIBER SPACER SEAL
1	4	38-0220046-00	PAPER SEAL
1	5	72-1080442-00	SPEAKER FLARE
1	6	38-0220047-00	METAL GASKET
1	7	22-1340360-03	ADAPTER SPEAKER
2	8	26-0111614-00	HOSE CLAMP
1	9	26-0911577-00	FLEXIBLE TUBING
8	10	26-0215001-11	TY-WRAP
1	11	22-1340359-04	ADAPTER SPEAKER
1	12	07-260490-010	MTG. BRKT - DRIVER
1	13	43-0215884-04	100 WATT DRIVER
4	14	NOT AVAILABLE	1/4-20X1/2 HEX HD CAPSCREW
4	15	NOT AVAILABLE	1/4" EXT TOOTH SST LOCKWASHER
2	19	22-0410510-00	TERMINAL CAP-PLASTIC / BLACK
1	20	67-1361699150	1/C 16 GA. WIRE WHT 15" LG. W/FASTON
1	21	67-1361600150	1/C 16 GA. WIRE BLK. 15" LG. W/FASTON
1	22	26-0610158-00	PVC TUBING-BLACK 6" LG
A/R	23	66-1416020-00	ANTI-SEIZE GREASE

NOTE: Items 1 through 7 are factory pre-assembled as a complete speaker horn assembly.



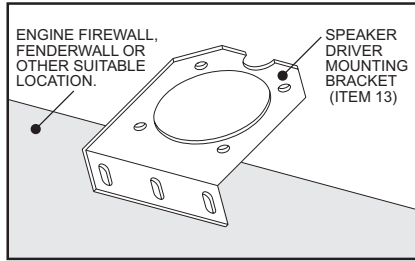
ACTIVATION OF THIS SIREN MAY DAMAGE UNPROTECTED EARS!

Wear Protection!

CAUTION

Loud siren noise can cause hearing damage and/or loss. Refer to OSHA Section 1910.95 prior to putting ANY siren into service!

FIG. 1

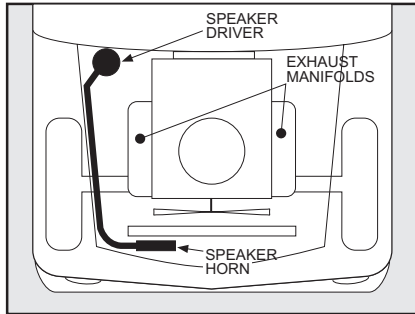


Choose desired mounting location and mark the mounting holes using the bracket as a template.

The standard length of the acoustical flexible tubing is 60", and is marked every 4" with a white dot. After installing the speaker driver and the speaker horn assembly in the desired locations, cut the flexible acoustical tubing to fit properly between these two units in the order as indicated in the drawing on this page. For optimum sound levels, it is very important to cut the flexible tubing at the 4" interval markings. example. If 46 inches of flexible tubing is desired, cut the tubing at either the 44" or 48" length. Acousticle flexible tubing lengths greater than 60 inches are available on special order.



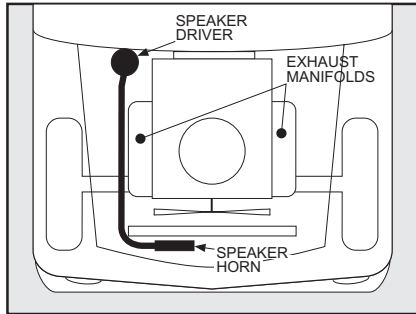
FIG. 2-A



Route acoustical flexible tubing away from engine exhaust manifolds or exhaust pipe.

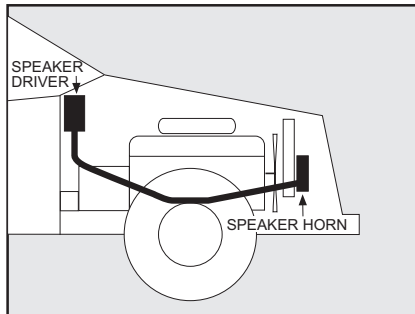


FIG. 2-B



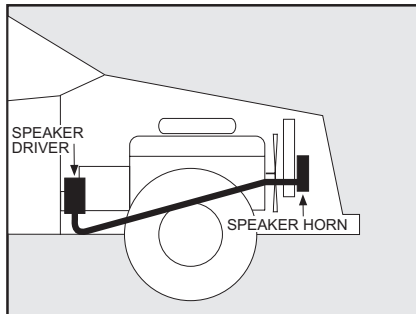
DO NOT route acoustical flexible tubing on or near engine exhaust manifolds or tail pipe.

FIG. 3-A



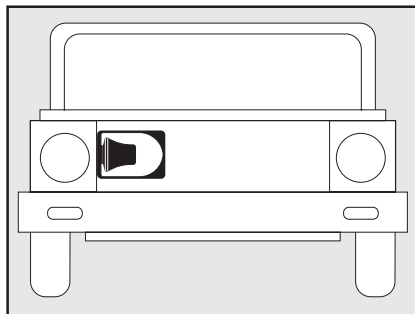
Install speaker driver at a higher level than the speaker horn. Drill a 1/8" diameter hole on the bottom of the acoustical tubing at the lowest point.

FIG. 3-B



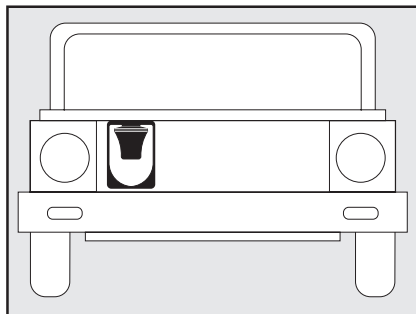
DO NOT Install speaker driver at a lower level than the speaker horn. water could enter speaker horn, be trapped inside and damage speaker.

FIG. 4-A



Mount speaker horn in a horizontal position to make sure water does not collect inside the speaker tip.

FIG. 4-B



DO NOT mount speaker horn in a vertical position will allow water to enter the speaker tip and cause permanent failure.

Installation Instructions:

1. Check the contents of the kit to insure that all parts and components are in the package. See exploded parts drawing on front page.
2. Determine the ideal mounting location for the driver and speaker horn assembly. Follow diagrams on left.
3. After the location for the speaker driver has been chosen, use the driver mounting bracket as a template for making and drilling the bracket mounting holes.
4. After the driver mounting bracket is securely mounted to the vehicle, install the speaker driver to the bracket using 1/4" X 20 X 1/2" hex head cap screws.
5. Install the driver adapter (item 11) to the speaker driver, making sure to insert the rubber seal (item 2) and fiber spacer seal (item 3) between the adapter and driver. Continue the assembly process in the sequence shown in the drawing on pg. 1.
6. Install the speaker horn assembly at the chosen location on the front grill of the vehicle (fig. 4). Speaker horn assembly may be secured with the enclosed ty-wraps (item 10).
7. Route the acoustical flexible tubing from the driver to the speaker horn assembly following the warnings to the left. To fit the acoustical tubing, cut it at the nearest 4" length (see text at the top of the page).
8. Clamp the flexible acoustical tubing securely over the speaker horn and driver adapters with the two hose clamps (item 8). Use ty-wraps (item 10) to secure acoustical tubing in place (figs. 2 & 3).

IMPORTANT: Due to the lightweight nature of some plastic front grilles, when mounting the speaker horn upon it, harmonic vibration (distortion) of the siren sound is possible. In this case use a mounting location for the speaker horn other than the speaker grille itself. Example: Grille Mounting Posts, Metal Bumper Flanges, etc.