

## WHELEN<sup>®</sup> ENGINEERING COMPANY INC.

51 Winthrop Road  
 Chester, Connecticut 06412-0684  
 Phone: (860) 526-9504  
 Fax: (860) 526-4078  
 Internet: [www.whelen.com](http://www.whelen.com)  
 Sales e-mail: [autosale@whelen.com](mailto:autosale@whelen.com)  
 Canadian Sales e-mail: [autocan@whelen.com](mailto:autocan@whelen.com)  
 Customer Service e-mail: [custserv@whelen.com](mailto:custserv@whelen.com)

### Installation Guide: SA314 Siren Speaker 1998-2002 Crown Victoria

**DANGER!** Sirens produces extremely loud emergency warning tones! Exposure to these tones without proper and adequate hearing protection, could cause ear damage and/or hearing loss! The Occupational Safety & Health Administration ([www.osha.gov](http://www.osha.gov)) provides information necessary to determine safe exposure times in Occupational Noise Exposure Section 1910.95. Until you have determined the safe exposure times for your specific application, operators and anyone else in the immediate vicinity should be required to wear an approved hearing protection device. **FAILURE TO FOLLOW THIS RECOMMENDATION COULD CAUSE HEARING LOSS!**

#### Safety First

This document provides all the necessary information to allow your Whelen product to be properly and safely installed. Before beginning the installation and/or operation of your new product, the installation technician and operator must read this manual completely. Important information is contained herein that could prevent serious injury or damage.

- Proper installation of this product requires the installer to have a good understanding of automotive electronics, systems and procedures.
- If mounting this product requires drilling holes, the installer **MUST** be sure that no vehicle components or other vital parts could be damaged by the drilling process. Check both sides of the mounting surface before drilling begins. Also de-burr any holes and remove any metal shards or remnants. Install grommets into all wire passage holes.
- If this manual states that this product may be mounted with suction cups, magnets, tape or Velcro™, clean the mounting surface with a 50/50 mix of isopropyl alcohol and water and dry thoroughly.
- Do not install this product or route any wires in the deployment area of your air bag. Equipment mounted or located in the air bag deployment area will damage or reduce the effectiveness of the air bag, or become a projectile that could cause serious personal injury or death. Refer to your vehicle owners manual for the air bag deployment area. The User/Installer assumes full responsibility to determine proper mounting location, based on providing ultimate safety to all passengers inside the vehicle.
- For this product to operate at optimum efficiency, a good electrical connection to chassis ground must be made. The recommended procedure requires the product ground wire to be connected directly to the **NEGATIVE (-)** battery post.
- If this product uses a remote device to activate or control this product, make sure this control is located in an area that allows both the vehicle and the control to be operated safely in any driving condition. **DO NOT ATTEMPT TO ACTIVATE OR CONTROL THIS DEVICE IN A HAZARDOUS DRIVING SITUATION.**
- It is recommended that these instructions be stored in a safe place and referred to when performing maintenance and/or reinstallation of this product.
- **FAILURE TO FOLLOW THESE SAFETY PRECAUTIONS AND INSTRUCTIONS COULD RESULT IN DAMAGE TO THE PRODUCT OR VEHICLE AND/OR SERIOUS INJURY TO YOU AND YOUR PASSENGERS!**

**ACTIVATION OF THIS  
SIREN MAY DAMAGE  
UNPROTECTED EARS!**



**CAUTION**

Loud siren noise can cause hearing damage and/or loss. Refer to OSHA Section 1910.95 prior to putting ANY siren into service!

**For warranty information regarding this product, visit [www.whelen.com/warranty](http://www.whelen.com/warranty)**

## Installation:

If you have a Crown Victoria built after the year 2001, you will find that the vehicle horn is installed in the mounting location described below. In order to install this siren, you must first remove the vehicle horn and install it where it is found on the 1998 to 2000 model Crown Victoria. (See: Moving the Vehicle Horn)

1. First attach the siren to the bracket using the supplied screws and washers as shown in figure 1.
2. Next you will need to remove the black plastic cover that covers the front of the engine compartment. there are 3 clips that twist open, holding the cover on. (Refer to vehicle manual)
3. On the radiator cross member you will find 2 sets of holes, one square, one round (Fig. 2). Insert the 2 extruded "U" nuts into the square hole so the extended screw sleeve goes into the round hole and faces toward the back of the vehicle. (The "U" nut must clip onto the cross member)

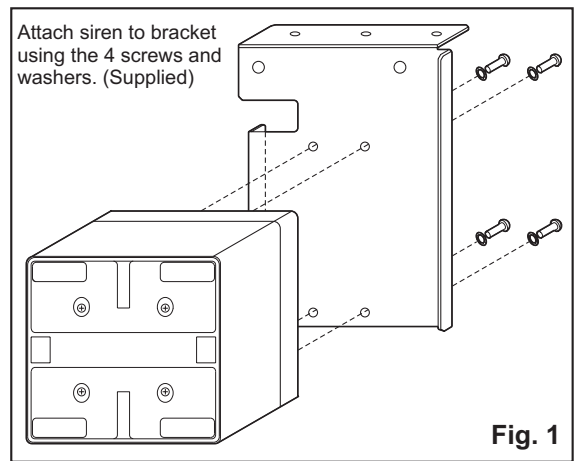

4. Next take the bracket with siren attached, place it on the mounting surface and attach it by screwing the 2 supplied bolts into the 2 "U" nuts (Fig. 3).

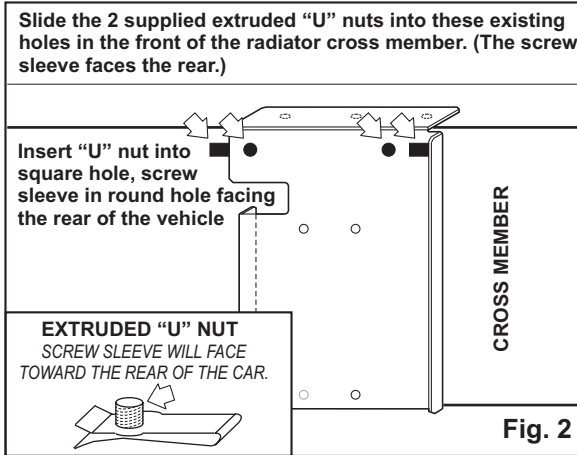

5. Now secure the bracket on top by screwing in the 3 supplied self tapping screws. (You will need to use a drill with a socket attached.)

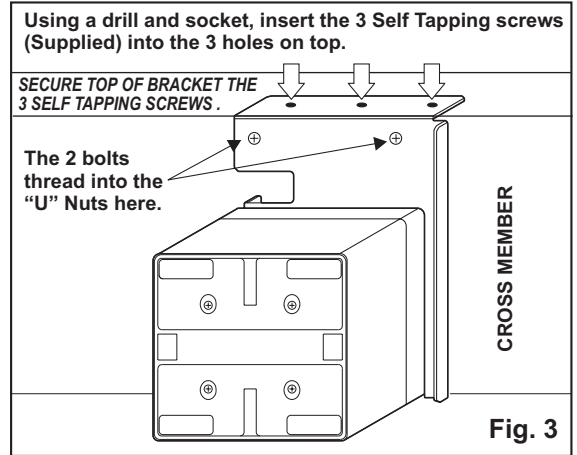

6. Extend the WHITE (Positive) and BLACK (Negative) speaker wires to your siren amplifier and connect as shown in the amplifiers instructions.

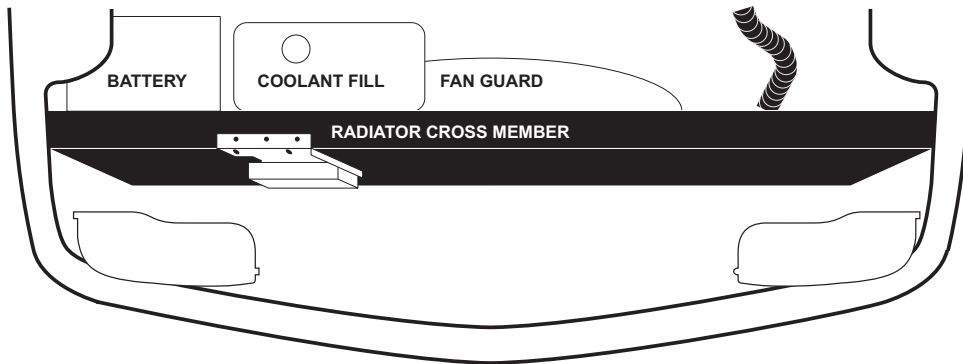

**ACTIVATION OF THIS SIREN MAY DAMAGE UNPROTECTED EARS!**

**CAUTION**

Loud siren noise can cause hearing damage and/or loss. Refer to OSHA Section 1910.95 prior to putting ANY siren into service!

**Wear Protection!**

**WARNING:** The siren speaker wires must exit through the bottom of the siren. The wire hole is also the drainage hole for the siren. Improper mounting will not only result in siren driver failure, but will also void the warranty.

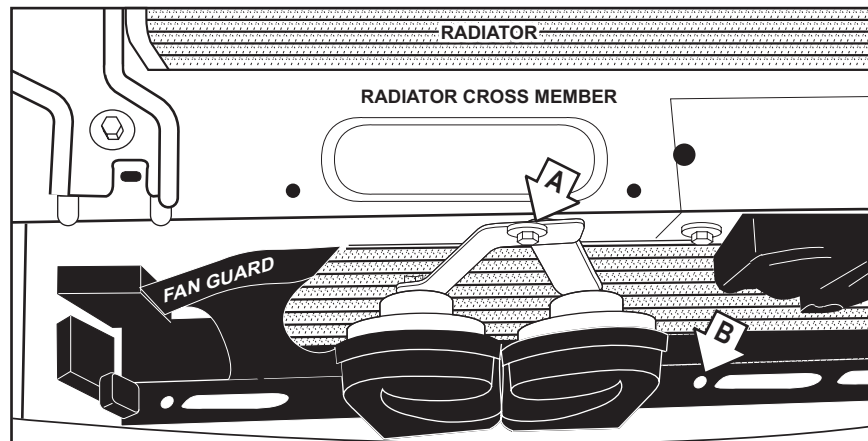

## Moving the Vehicle Horn:

Remove the vehicle horn from its present location (A). Mount the horn on the black metal cross member located right below the horns original mounting location (B). (A new mounting bolt for the horn is included with your siren) Now you may mount the siren in the location described above. siren as described above.

**Note:** You may have to mount the horn on a slight angle to accommodate the tab located near the mounting bolt on the horn's bracket.