

ROUTE 145, WINTHROP ROAD  
CHESTER, CONNECTICUT 06412-0684  
TELEPHONE: (860) 526-9504  
FAX: (860) 526-4078

### Installation:

1. Position the lighthead in its approximate mounting location to make sure that the lighthead will not interfere with any existing equipment. Also be aware of any and all items on the opposite side of the mounting surface to prevent any possible damage to existing components.
2. Remove the lighthead, position the supplied mounting template onto the mounting location and temporarily secure it to the surface. The template must be FLAT against the surface.
3. Using an appropriately sized drill bit, drill the mounting holes as shown on the template.
4. Using a cutting tool, cut an opening in the mounting surface as indicated on the template.
5. Route the cable assembly to your power supply.
6. Plug the lighthead into the cable and plug the cable into the power supply. Test operation of the lighthead before securing it to the vehicle.
7. Secure the assembly onto the mounting surface with the supplied sheetmetal screws.

**NOTE:** Before proceeding, place the reflector against the template and confirm that the mounting holes on the template line up with the actual mounting holes on the reflector.

**NOTE:** All customer supplied wires that connect to the positive terminal of the battery, must be sized to supply at least 125% of the maximum operating current and fused at the battery to carry the load.

3. Using an appropriately sized drill bit, drill the mounting holes as shown on the template.

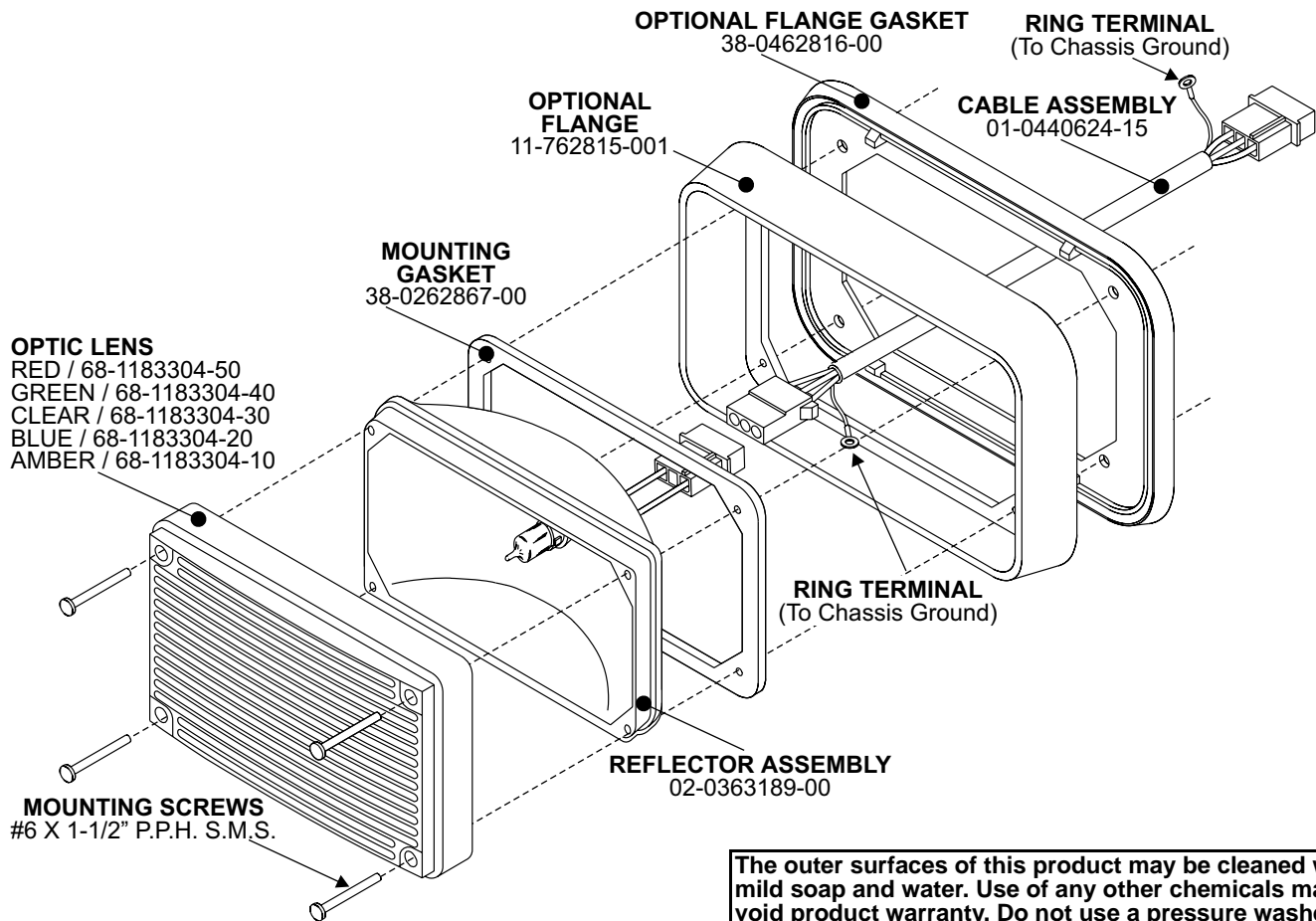

The outer surfaces of this product may be cleaned with mild soap and water. Use of any other chemicals may void product warranty. Do not use a pressure washer.

# DO NOT PHOTOCOPY

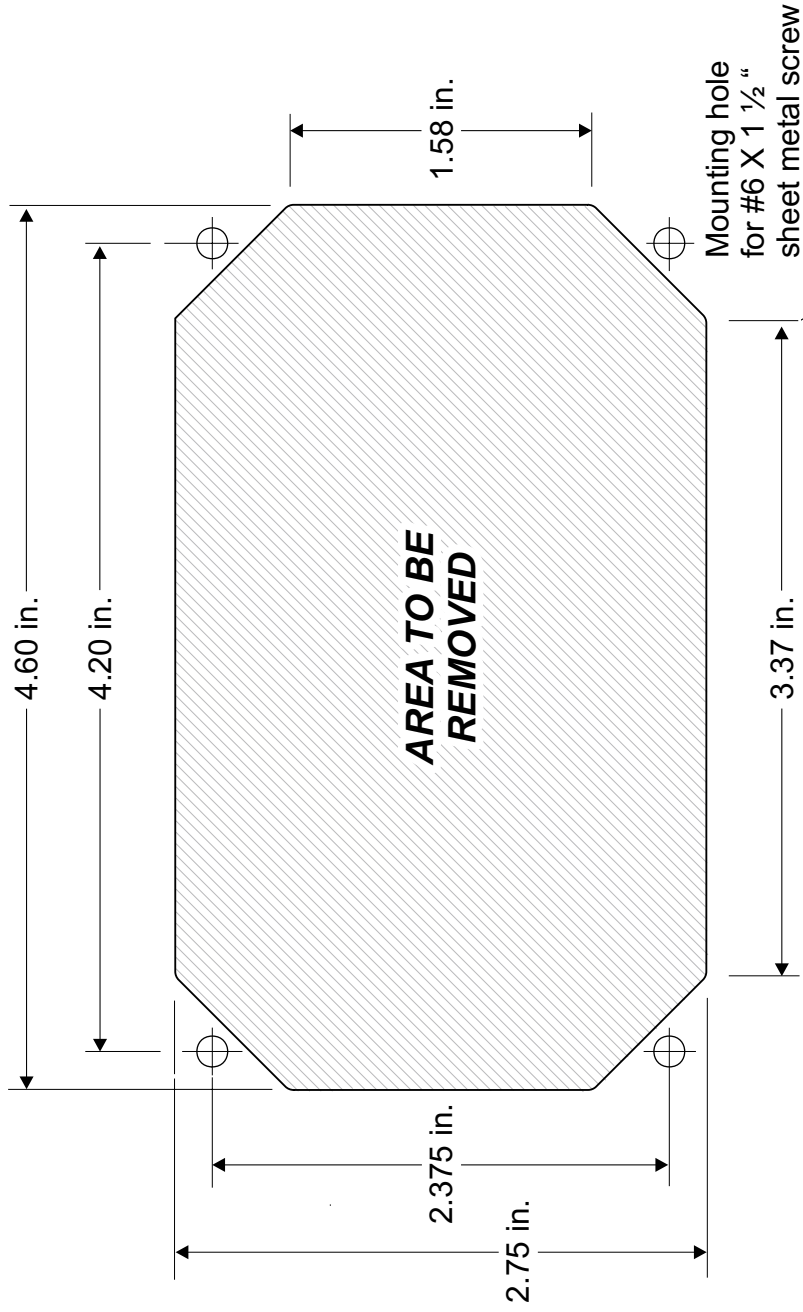

**IMPORTANT NOTE!!**  
The template(s) included with this manual  
MAY NOT BE TO SCALE.  
Before drilling, CONFIRM ALL DIMENSIONS.

**MTG. HOLE FOR #6 X 1 1/2" SHEET METAL SCREW**