

WHELEN[®]

ENGINEERING COMPANY INC.

Route 145, Winthrop Road,
Chester, Connecticut 06412

Phone: (860) 526-9504

Fax: (860) 526-4078

Internet: www.whelen.com

Sales e-mail: autosale@whelen.com

Canadian Sales e-mail: autocan@whelen.com

Customer Service e-mail: custserv@whelen.com

Installation Manual 43 LED Lighthouse

Safety First

This document provides all the necessary information to allow your Whelen product to be properly and safely installed. Before beginning the installation and/or operation of your new product, the installation technician and operator must read this manual completely. Important information is contained herein that could prevent serious injury or damage.

- **Proper installation of this product requires the installer to have a good understanding of automotive electronics, systems and procedures.**
- **If mounting this product requires drilling holes, the installer MUST be sure that no vehicle components or other vital parts could be damaged by the drilling process. Check both sides of the mounting surface before drilling begins. Also de-burr any holes and remove any metal shards or remnants. Install grommets into all wire passage holes.**
- **If this product is mounted with tape or Velcro™, clean the mounting surface with a 50/50 mix of isopropyl alcohol and water and dry thoroughly.**
- **Do not install this product or route any wires in the deployment area of your air bag. Equipment mounted or located in the air bag deployment area will damage or reduce the effectiveness of the air bag, or become a projectile that could cause serious personal injury or death. Refer to your vehicle owners manual for the air bag deployment area. The User/Installer assumes full responsibility to determine proper mounting location, based on providing ultimate safety to all passengers inside the vehicle.**
- **For this product to operate at optimum efficiency, a good electrical connection to chassis ground must be made. The recommended procedure requires the product ground wire to be connected directly to the NEGATIVE (-) battery post.**
- **If this product uses a remote device to activate or control this product, make sure that this control is located in an area that allows both the vehicle and the control to be operated safely in any driving condition.**
- **Do not attempt to activate or control this device in a hazardous driving situation.**
- **This product contains either strobe light(s), halogen light(s), high-intensity LEDs or a combination of these lights. Do not stare directly into these lights. Momentary blindness and/or eye damage could result.**
- **Use only soap and water to clean the outer lens. Use of other chemicals could result in premature lens cracking (crazing) and discoloration. Lenses in this condition have significantly reduced effectiveness and should be replaced immediately. Inspect and operate this product regularly to confirm its proper operation and mounting condition. Do not use a pressure washer to clean this product.**
- **It is recommended that these instructions be stored in a safe place and referred to when performing maintenance and/or reinstallation of this product.**
- **FAILURE TO FOLLOW THESE SAFETY PRECAUTIONS AND INSTRUCTIONS COULD RESULT IN DAMAGE TO THE PRODUCT OR VEHICLE AND/OR SERIOUS INJURY TO YOU AND YOUR PASSENGERS!**

Installation:

1. Using the dimensions from the template, mark off and drill the two 5/16 inch diameter vent tube holes and the 1 inch center wire hole into the mounting surface. **NOTE:** Make sure lighthouse will not interfere with existing equipment and be aware of any items on the opposite side of the mounting surface.
2. Insert the 2 vent tubes extending from the rear of the lighthouse into their holes. With a scribe or similar tool, mark off the 4 mounting holes.
3. Using a drill bit sized for a #6 sheet metal screw (and the thickness of the mounting surface), drill the four mounting holes. Install a grommet (customer supplied) into the 1 inch wire hole.
4. Using appropriately sized wires (Minimum wire size / 18 AWG), run the lighthouse wires to their connections. (See Wire Color / Function tables) Fuse the +12VDC connections at 3 Amps and test operation of lighthouse before securing it to vehicle.
5. Position the lighthouse onto the mounting surface and secure to the vehicle using four #6 x 1-1/4" sheet metal screws.

Note: This product draws significantly less current than a standard incandescent automotive bulb. If your flasher does not operate properly, it may be necessary to replace your existing flasher module with a Whelen 3TERM flasher module. Contact your sales representative for specific vehicle application.

WARNING! The outer surfaces of this product may be cleaned with mild soap and water. Use of any other chemicals may void product warranty. Do not use a pressure washer.

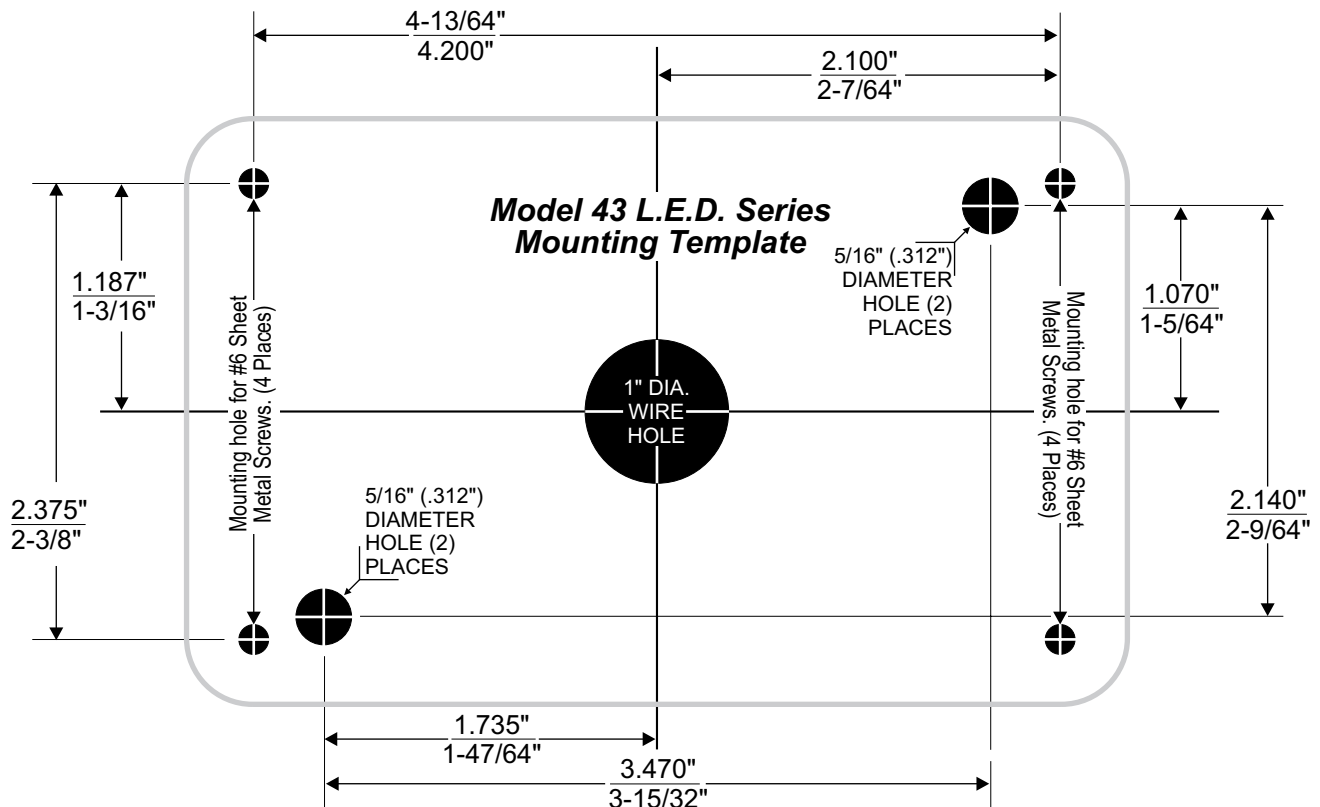

IMPORTANT: Templates may not be exactly to scale. Always check all measurements before drilling. Measurements are given in both Decimals and Fractions for convenience. For a more accurate measurement and installation, we recommend you use the Decimals.

QTY.	QTY.	QTY.	QTY.	QTY.	QTY.	QTY.	QTY.	QTY.	QTY.	ITEM	PART NUMBER	DESCRIPTION	
									*		01-06834592RR	ASSEMBLY / LIGHTHEAD MODEL 43 BRAKE-TAIL-TURN / MIN	
									*		01-06834595AA	ASSEMBLY / LIGHTHEAD MODEL 43 LED FLASHER - AMBER	
									*		01-06834595BB	ASSEMBLY / LIGHTHEAD MODEL 43 LED FLASHER - BLUE	
									*		01-06834595GG	ASSEMBLY / LIGHTHEAD MODEL 43 LED FLASHER - GREEN	
									*		01-06834595RR	ASSEMBLY / LIGHTHEAD MODEL 43 LED FLASHER - RED	
				*					*		01-06834595CW	ASSEMBLY / LIGHTHEAD MODEL 43 LED FLASHER - WHITE	
		*							*		01-0683459BRR	ASSEMBLY / LIGHTHEAD MODEL 43 LED BRAKE-TAIL-TURN / MAX	
	*								*		01-06834596CW	ASSEMBLY / LIGHTHEAD MODEL 43 LED FLOOD - WHITE	
*									*		01-06834597CW	ASSEMBLY / LIGHTHEAD MODEL 43 LED BACK-UP - WHITE	
4	4	4	4	4	4	4	4	4	4	1	15-061416-200	#6 X 1-1/4" PHILLIPS PAN HEAD SHEET METAL SCREW	
-	-	-	-	-	-	-	-	-	1	-	2	68-1183071-1S	LENS / AMBER
-	-	-	-	-	-	-	-	-	1	-	3	68-1183071-2S	LENS / BLUE
1	1	-	1	-	-	-	-	-	-	-	4	68-1183071-3S	LENS / CLEAR
-	-	-	-	-	-	1	-	-	-	-	5	68-1183071-4S	LENS / GREEN
-	-	1	-	1	-	-	-	-	-	-	6	68-1183071-5S	LENS / RED
-	-	-	-	-	-	-	-	-	-	1	7	01-0283458-52	SUB ASSEMBLY / 43 LED BRAKE-TAIL-TURN / MIN
-	-	-	-	-	-	-	-	-	1	-	8	01-0283458-15	SUB ASSEMBLY / 43 LED FLASHER - AMBER
-	-	-	-	-	-	-	1	-	-	-	9	01-0283458-25	SUB ASSEMBLY / 43 LED FLASHER - BLUE
-	-	-	-	-	-	1	-	-	-	-	10	01-0283458-45	SUB ASSEMBLY / 43 LED FLASHER - GREEN
-	-	-	-	-	1	-	-	-	-	-	11	01-0283458-55	SUB ASSEMBLY / 43 LED FLASHER - RED
-	-	-	1	-	-	-	-	-	-	-	12	01-0283458-35	SUB ASSEMBLY / 43 LED FLASHER - WHITE
-	-	1	-	-	-	-	-	-	-	-	13	01-0283458-5B	SUB ASSEMBLY / 43 LED BRAKE-TAIL-TURN / MAX
-	1	-	-	-	-	-	-	-	-	-	14	01-0283458-36	SUB ASSEMBLY / 43 LED FLOOD - WHITE
1	-	-	-	-	-	-	-	-	-	-	15	01-0268971-00	SUB ASSEMBLY / 43 LED BACK-UP - WHITE
1	1	1	1	1	1	1	1	1	1	1	16	38-0262867-00	GASKET

ITEM	DEFAULT PATTERN and INPUT CURRENT
7 -	SIGNAL ALERT™ BRAKE Input Current 0.060 / 0.375 Amps
8 -	SIGNAL ALERT™ Input Current .375 Amps
9 -	SIGNAL ALERT™ Input Current .300 Amps
10 -	SIGNAL ALERT™ Input Current .300 Amps
11 -	SIGNAL ALERT™ Input Current .375 Amps
12 -	SIGNAL ALERT™ Input Current .300 Amps
13 -	SIGNAL ALERT™ BRAKE Input Current 0.055 / 0.425 Amps
14 -	STEADY Input Current 0.265
15 -	STEADY Input Current 0.225

INPUT VOLTAGE: 12.8 VDC +/-20%

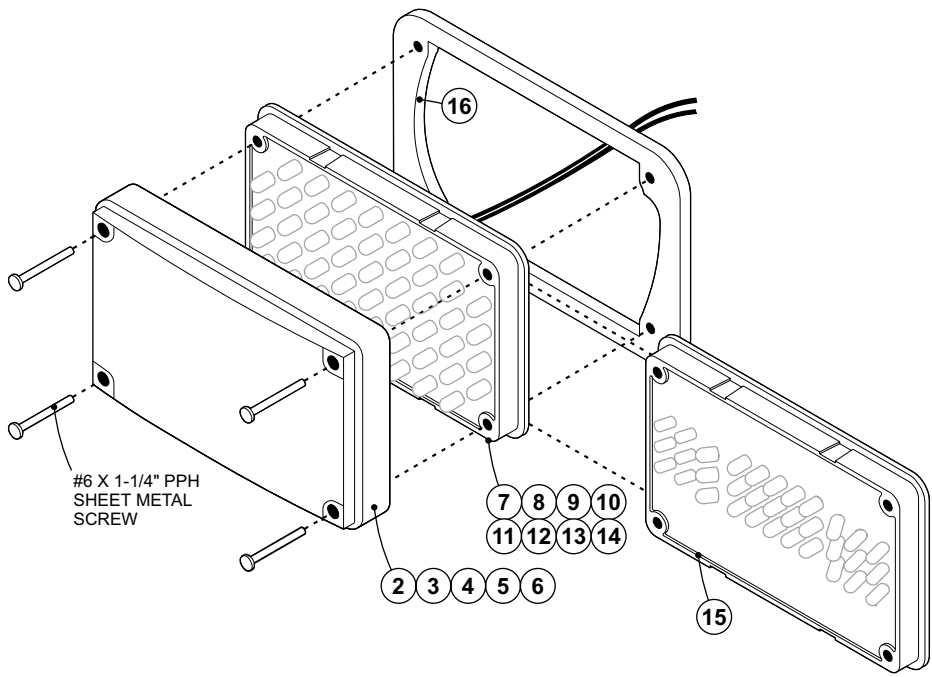

FLASHER	
Wire	Function
Colored Wire color will be whatever the color of its LED is. (When light is switched on.)	+12 VDC
Black	Ground

BRAKE / TAIL / TURN	
Wire Color	Function
Yellow	+ 12 VDC / Brake / Turn
Brown	+12 VDC / Tail
White	To Chassis Ground

PATTERN SELECTION PROCEDURE:

IMPORTANT: Pattern selection requires the LED to be turned on. DO NOT LOOK DIRECTLY AT THE LEDs WHILE THE UNIT IS IN OPERATION.

NOTE: Although the location of the pins varies for each LED board, this procedure is applicable to all LED boards that offer selectable patterns. The location of these pins will vary between models, but they will always be on the LED side of the circuit board.

1. Remove the lens and locate the Pattern Activation Pins for your model LED. (Section of typical L.E.D. board below shows pins.)
2. Turn the LED flasher on.

- 3A. **TO CYCLE FORWARD THROUGH ALL PATTERNS:**
Use a penny (or any electrical conducting item) to contact both Pattern Activation Pins for less than 1 second & release. Repeat for next pattern.
- 3B. **TO CHOOSE A PATTERN:**
While cycling through the patterns, allow a pattern to run for more than five seconds, this will become the default pattern until it is changed.
- 3C. **TO CYCLE BACKWARDS THROUGH ALL PATTERNS:**
Hold penny against Activation Pins for more than 1 second and release. When you've chosen a pattern, turn off power and re-mount lens.

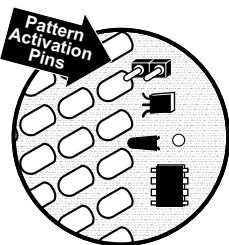

AVAILABLE FLASH PATTERNS:

- RAPIDFIRE™ 375** - 375 Single Flashes Per Minute
- RAPIDFIRE™ 150** - 150 Single Flashes Per Minute
- RAPIDFIRE™ 75** - 75 Single Flashes Per Minute
- RAPIDFIRE™ 30** - 30 Single Flashes Per Minute
- DOUBLE FLASH 150** - 150 Double Flashes Per Minute
- DOUBLE FLASH 75** - 75 Double Flashes Per Minute
- COMET FLASH®** - 75 Comet Flashes Per Minute
- ACTION FLASH™** - 2 Comet Flash / 4 X 150 SFP / 2 Comet
- MODU FLASH™** - 75 to 360 Single Flashes Per Minute
- SIGNAL ALERT™ 150** - 150 Flashes Per Minute
- SIGNAL ALERT™ 75** - 75 Flashes Per Minute Followed by Steady Burn
- STANDARD BRAKE** - Steady Burn
- SCAN** - 2 Cycles of Patterns 3 thru 12
- SIGNAL ALERT™ BRAKE** - 4 Flashes Cycle For 200 MS