

# WHELEN<sup>®</sup>

ENGINEERING COMPANY INC.

Route 145, Winthrop Road,  
Chester, Connecticut 06412  
Phone: (860) 526-9504  
Fax: (860) 526-4078  
Internet: [www.whelen.com](http://www.whelen.com)  
Sales e-mail: [autosale@whelen.com](mailto:autosale@whelen.com)  
Canadian Sales e-mail: [autocan@whelen.com](mailto:autocan@whelen.com)  
Customer Service e-mail: [custserv@whelen.com](mailto:custserv@whelen.com)

## Installation Guide Model 43 Strobe-Halogen or Strobe/LED Lighthouse

### Safety First

This document provides all the necessary information to allow your Whelen product to be properly and safely installed. Before beginning the installation and/or operation of your new product, the installation technician and operator must read this manual completely. Important information is contained herein that could prevent serious injury or damage.

- **Proper installation of this product requires the installer to have a good understanding of automotive electronics, systems and procedures.**
- **If mounting this product requires drilling holes, the installer MUST be sure that no vehicle components or other vital parts could be damaged by the drilling process. Check both sides of the mounting surface before drilling begins. Also de-burr any holes and remove any metal shards or remnants. Install grommets into all wire passage holes.**
- **If this product is mounted with tape or Velcro<sup>™</sup>, clean the mounting surface with a 50/50 mix of isopropyl alcohol and water and dry thoroughly.**
- **Do not install this product or route any wires in the deployment area of your air bag. Equipment mounted or located in the air bag deployment area will damage or reduce the effectiveness of the air bag, or become a projectile that could cause serious personal injury or death. Refer to your vehicle owners manual for the air bag deployment area. The User/Installer assumes full responsibility to determine proper mounting location, based on providing ultimate safety to all passengers inside the vehicle.**
- **For this product to operate at optimum efficiency, a good electrical connection to chassis ground must be made. The recommended procedure requires the product ground wire to be connected directly to the NEGATIVE (-) battery post.**
- **If this product uses a remote device to activate or control this product, make sure that this control is located in an area that allows both the vehicle and the control to be operated safely in any driving condition.**
- **Do not attempt to activate or control this device in a hazardous driving situation.**
- **This product contains either strobe light(s), halogen light(s), high-intensity LEDs or a combination of these lights. Do not stare directly into these lights. Momentary blindness and/or eye damage could result.**
- **Use only soap and water to clean the outer lens. Use of other chemicals could result in premature lens cracking (crazing) and discoloration. Lenses in this condition have significantly reduced effectiveness and should be replaced immediately. Inspect and operate this product regularly to confirm its proper operation and mounting condition. Do not use a pressure washer to clean this product.**
- **It is recommended that these instructions be stored in a safe place and referred to when performing maintenance and/or reinstallation of this product.**
- **FAILURE TO FOLLOW THESE SAFETY PRECAUTIONS AND INSTRUCTIONS COULD RESULT IN DAMAGE TO THE PRODUCT OR VEHICLE AND/OR SERIOUS INJURY TO YOU AND YOUR PASSENGERS!**

**Installation:**

1. Position the lighthouse in its approximate mounting location. Make sure that the lighthouse will not interfere with any existing equipment or items on the opposite side of the mounting surface.
  2. Position the supplied mounting template on the mounting location and temporarily secure it to the surface. Be sure the template is FLAT against the surface.
- NOTE:** Before proceeding, place the reflector against the template and confirm that the mounting holes on the template line up with the actual mounting holes on the reflector.
3. Using an appropriately sized drill bit, drill the mounting holes.

4. Cut an opening in the mounting surface as indicated on the template.
5. Route the cable assembly towards the strobe power supply. Be sure that both ring terminals are grounded to the vehicle chassis ground.
6. Plug the lighthouse into the cable and plug the cable into the strobe power supply. Test lighthouse before securing it to the vehicle.
7. Secure the assembly onto the mounting surface with the supplied sheet metal screws.

**IMPORTANT!** If a Strobe/LED lighthouse is being installed, the LED must be used with a flasher. Do not wire the LED for steady on activation.

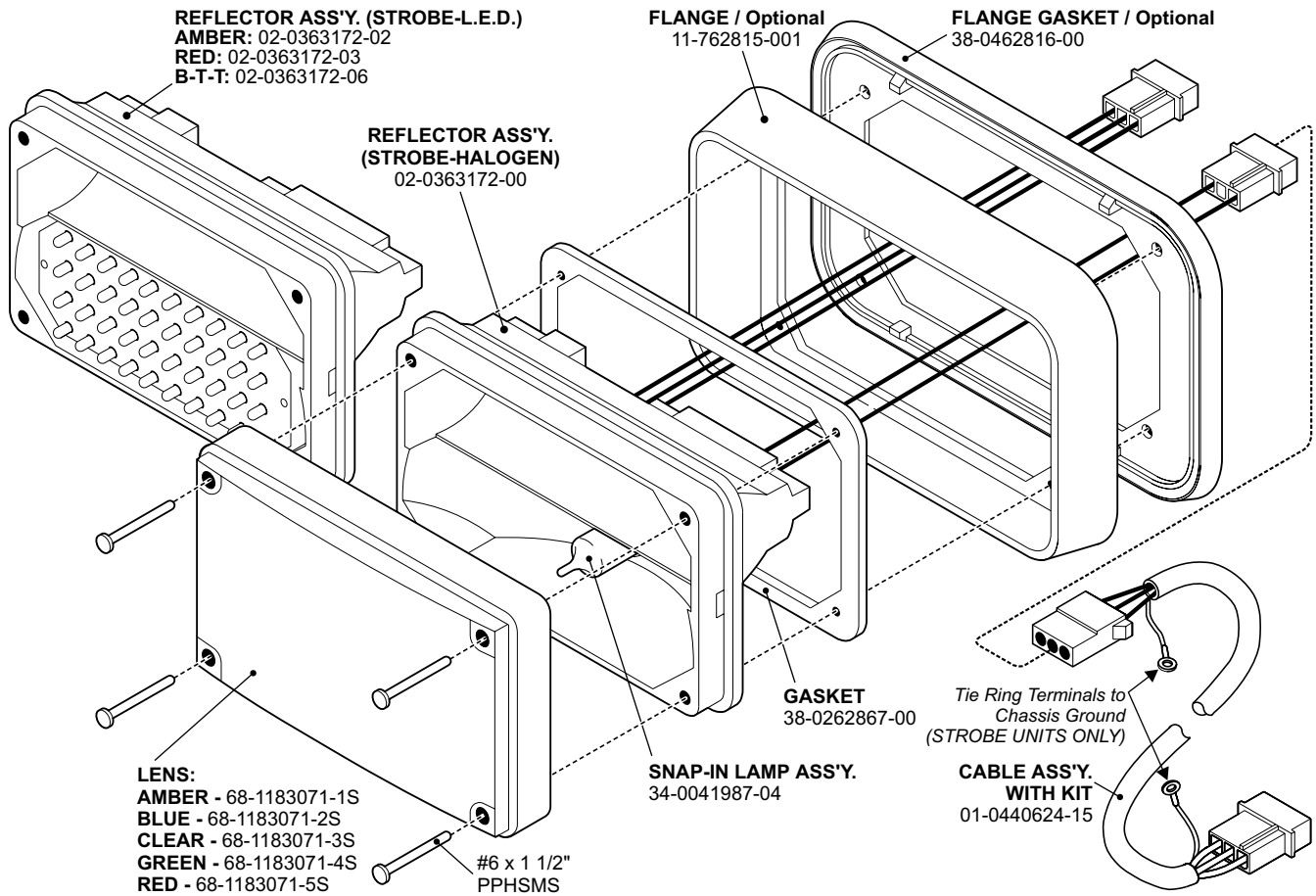

**IMPORTANT NOTE:** The outer surfaces of this product may be cleaned with mild soap and water. Use of any other chemicals may void the product warranty. Do not use a pressure washer.

**WARNING:** All customer supplied wires that connect to the positive terminal of the battery, must supply at least 125% of the maximum operating current, and be fused at the battery, to carry the load.

**WARNING:** The strobe power supply is a high voltage device. do not touch the strobe tube or power supply assembly while the unit is in operation. Wait at least 10 minutes after turning off the power before starting any work or trouble shooting.

