

# WHELEN<sup>®</sup>

ENGINEERING COMPANY INC.

51 Winthrop Road  
Chester, Connecticut 06412-0684  
Phone: (860) 526-9504  
Fax: (860) 526-4078  
Internet: [www.whelen.com](http://www.whelen.com)  
Sales e-mail: [autosale@whelen.com](mailto:autosale@whelen.com)  
Canadian Sales e-mail: [autocan@whelen.com](mailto:autocan@whelen.com)  
Customer Service e-mail: [custserv@whelen.com](mailto:custserv@whelen.com)

## Installation Guide: Edge<sup>®</sup> Ultra Lightbar (LC Series)

### Safety First

This document provides all the necessary information to allow your Whelen product to be properly and safely installed. Before beginning the installation and/or operation of your new product, the installation technician and operator must read this manual completely. Important information is contained herein that could prevent serious injury or damage.

- Proper installation of this product requires the installer to have a good understanding of automotive electronics, systems and procedures.
- If mounting this product requires drilling holes, the installer **MUST** be sure that no vehicle components or other vital parts could be damaged by the drilling process. Check both sides of the mounting surface before drilling begins. Also de-burr any holes and remove any metal shards or remnants. Install grommets into all wire passage holes.
- If this manual states that this product may be mounted with suction cups, magnets, tape or Velcro<sup>®</sup>, clean the mounting surface with a 50/50 mix of isopropyl alcohol and water and dry thoroughly.
- Do not install this product or route any wires in the deployment area of your air bag. Equipment mounted or located in the air bag deployment area will damage or reduce the effectiveness of the air bag, or become a projectile that could cause serious personal injury or death. Refer to your vehicle owner's manual for the air bag deployment area. The User/Installer assumes full responsibility to determine proper mounting location, based on providing ultimate safety to all passengers inside the vehicle.
- For this product to operate at optimum efficiency, a good electrical connection to chassis ground must be made. The recommended procedure requires the product ground wire to be connected directly to the **NEGATIVE (-)** battery post.
- If this product uses a remote device to activate or control this product, make sure that this control is located in an area that allows both the vehicle and the control to be operated safely in any driving condition.
- Do not attempt to activate or control this device in a hazardous driving situation.
- This product contains either strobe light(s), halogen light(s), high-intensity LEDs or a combination of these lights. Do not stare directly into these lights. Momentary blindness and/or eye damage could result.
- Use only soap and water to clean the outer lens. Use of other chemicals could result in premature lens cracking (crazing) and discoloration. Lenses in this condition have significantly reduced effectiveness and should be replaced immediately. Inspect and operate this product regularly to confirm its proper operation and mounting condition. Do not use a pressure washer to clean this product.
- It is recommended that these instructions be stored in a safe place and referred to when performing maintenance and/or reinstallation of this product.
- **FAILURE TO FOLLOW THESE SAFETY PRECAUTIONS AND INSTRUCTIONS COULD RESULT IN DAMAGE TO THE PRODUCT OR VEHICLE AND/OR SERIOUS INJURY TO YOU AND YOUR PASSENGERS!**

**For warranty information regarding this product, visit [www.whelen.com/warranty](http://www.whelen.com/warranty)**

**IMPORTANT! The lightbar should be located a minimum of 16" from any radio antennas!**

**Permanent Mounting:**

1. Locate the mounting foot and locking plate included with your lightbar. If not already present, install the locking plate onto the mounting foot. When properly positioned, this plate is centered from side to side on the mounting foot.
2. Flip the lightbar upside-down to expose the bottom of the extrusion and place the mounting foot onto the extrusion.
3. Rotate the mounting foot 90° in a counter-clockwise direction. Make sure that the edges of the mounting foot swing into position under the extrusion mounting lip.
4. Repeat this procedure for the remaining mounting foot and return the lightbar to its right side-up position.
5. Position the lightbar onto the vehicle roof in the desired mounting location. One often selected location is directly above the B-pillars. This area is the strongest part of the roof. Refer to your lightbar manual for cable exit location, to be sure that the lightbar is facing the proper direction.
6. Adjust the two mounting feet outwards so that they are as close to the edge of the roof as possible. Make sure that both mounting feet are in full contact with the roof. Be sure that there is no less than 1/2" clearance between the roof and the lightbar at their closest point. When the mounting feet are in their proper position, lightly tighten the locking plate allen head set screws.
7. Turn the lightbar upside down and firmly tighten all of the set screws from step 6 (2 or 4 per side).
8. On the adjustable foot, use the hole in the pad as a guide to drill the two holes into the mounting foot at the locations shown.

**Strap Mounting:**

1. Locate the mounting foot, anchor plate and locking plate included with your lightbar. If not already present, install the locking plate onto the mounting foot. When properly positioned, this plate is centered from side-to-side on the mounting foot.
2. Flip the lightbar upside-down to expose the bottom of the extrusion and place the mounting foot onto the extrusion.
3. Rotate the mounting foot 90° in a counter-clockwise direction. Make sure that the edges of the mounting foot swing into position under the extrusion mounting lip. Install an anchor plate onto the extrusion in the same manner.
4. Repeat this procedure for the remaining mounting foot and anchor plate and return the lightbar to its right side-up position.
5. Position the lightbar onto the vehicle roof in the desired mounting location. One often selected location is directly above the B-pillars. This area is the strongest part of the roof. Refer to your lightbar manual for cable exit location, to be sure that the lightbar is facing the proper direction.
6. Adjust the two mounting feet outwards so that they are as close to the edge of the roof as possible. Both mounting feet must be in full contact with the roof. Be sure that there is no less than 1/2" clearance between roof and lightbar at their closest point. When the mounting feet are in their proper position, lightly tighten the locking plate allen head set screws.

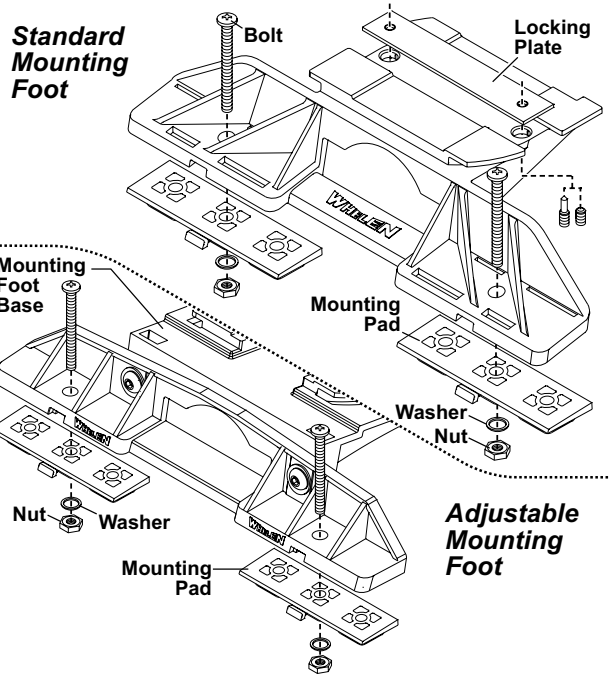

9. Place the lightbar in its final mounting position on the vehicle, mark the mounting hole locations off onto the mounting surface, remove the lightbar and drill the mounting holes.
10. Place the lightbar back onto the vehicle lined up with the mounting holes and secure the mounting feet to the vehicle with the supplied hardware.
7. Return the lightbar to an upside-down position. Slide each anchor plate outwards until it is fully engaged with its corresponding mounting foot. With the mounting feet and anchor plates in their proper positions firmly tighten all of the set screws (2 or 4 per side). Flip the lightbar right side-up and return it to its mounting position.
8. Open both drivers side doors. In the area directly below the mounting foot, pull the weatherstrip away from the vehicle so the area where the mounting strap will be secured is exposed. Repeat for the other side.
9. Insert the mounting strap through the mounting foot. Be sure that the strap fits flush against the area where it will be secured onto the vehicle. Insert the tension bolt through the mounting strap and anchor plate, into the tinnerman nut. Tighten slightly with a long-shafted, Phillips screwdriver. Repeat procedure for passenger side.
10. If your mounting strap has mounting holes in the end of the strap, use these holes as a template to drill appropriately sized pilot holes through the strap and into the vehicle. Repeat for passenger side of the vehicle.
11. Firmly tighten the tension bolts to secure the lightbar to the vehicle.

**NOTE: Model MKAJ is an adjustable mounting foot. On this model you may loosen the screws on the rear of the foot and adjust the angle of the lightbar. This feature can be used if the angle of the roof is not level with the road. IMPORTANT: To adjust the leveling screws you must use a torque wrench set at 35 to 40in./lbs.**

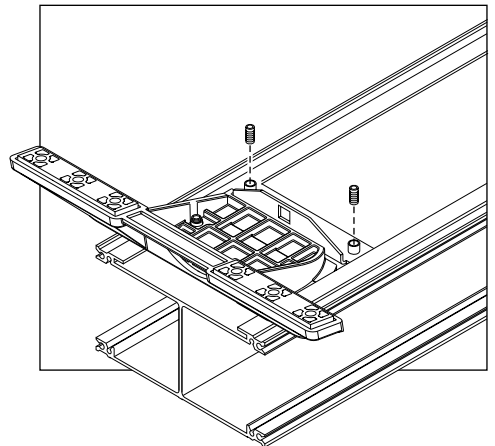
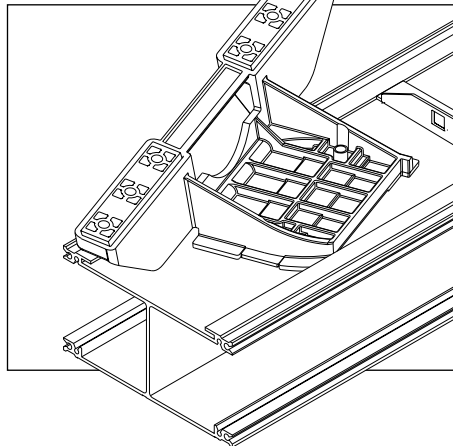
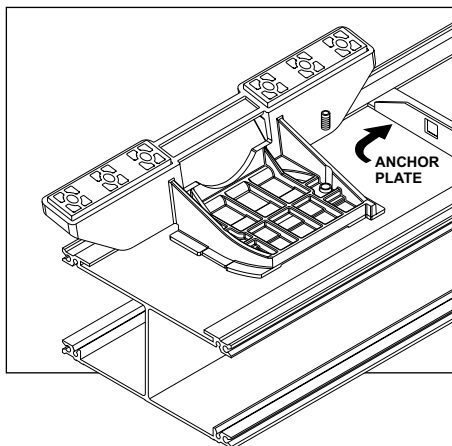

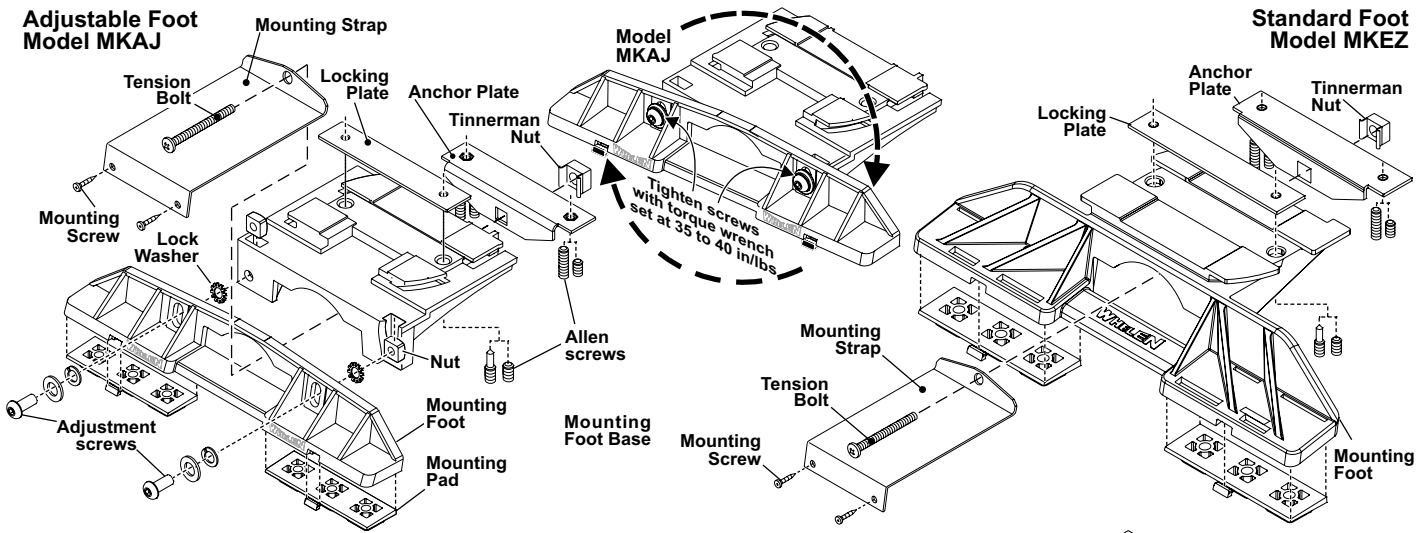

### 5" Mounting Foot

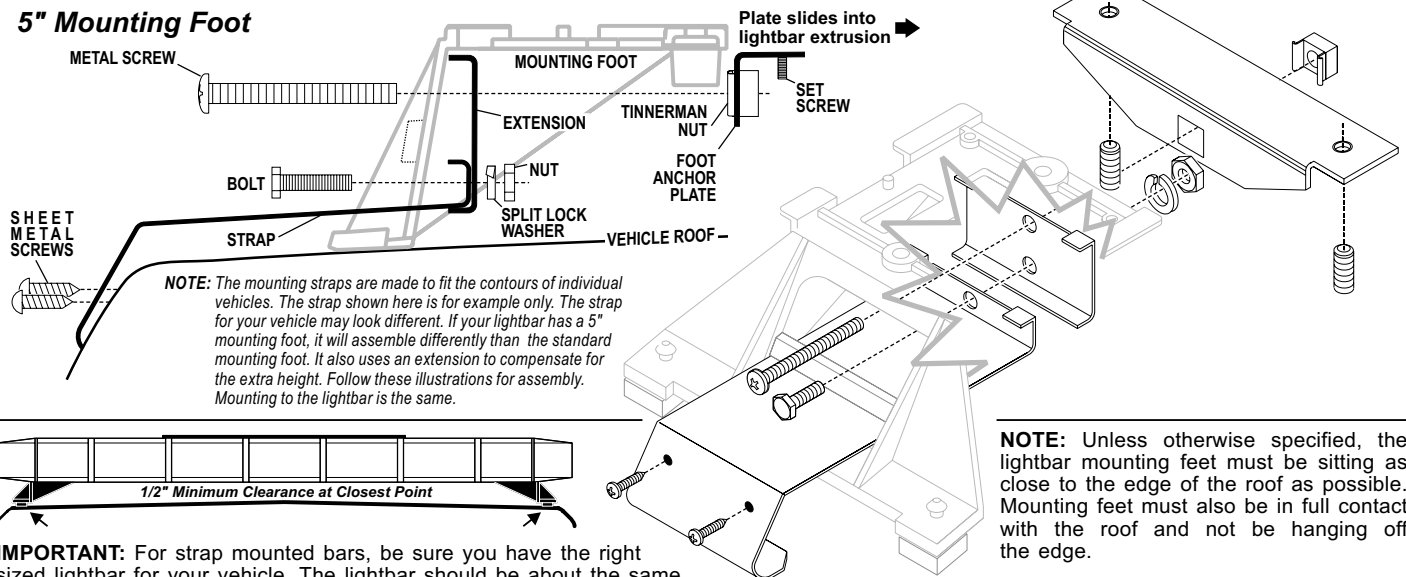

**NOTE:** Unless otherwise specified, the lightbar mounting feet must be sitting as close to the edge of the roof as possible. Mounting feet must also be in full contact with the roof and not be hanging off the edge.

**IMPORTANT:** For strap mounted bars, be sure you have the right sized lightbar for your vehicle. The lightbar should be about the same width as the vehicle roof. If the lightbar is too large or small it will not mount properly to the vehicle and may shift or come loose during driving.

### Routing your Edge Lightbar Cable(s)

1. To protect the headliner from damage caused by drilling the cable access hole through the vehicle roof, allow a 5" to 7" distance between roof and headliner by lowering the headliner before drilling.
2. Using a 1" hole saw, drill the cable access hole.

**NOTE:** There may be a roof support member that spans the distance between the driver's and passenger's side. **DO NOT DRILL THROUGH THIS MEMBER!** Adjust the location until the hole can be drilled without contacting this support member.

3. Use a round file to smooth and de-burr the edges of the hole.
4. Insert a 1" grommet (user supplied) into the cable access hole.
5. Insert the cable(s) through the cable access hole into the vehicle. Use RTV silicone to weatherproof the access hole after the cable(s) are pulled completely into the vehicle.
6. Route the cable(s) down through the B-pillar. The cable(s) must make a 90° turn to enter the B-pillar. Although routing the cable in this manner may be difficult, this has been determined to be the best procedure. It is up to the installation technicians discretion whether to route the cable(s) as recommended or use an alternative route. Pull the full length of the cable(s) out of the hole at the base of the B-pillar (Fig. 1) and route towards your switch panel. Refer to the instructions included with your switches for switch wiring information.

### Connecting the Cables

**WARNING!** All customer supplied wires that connect to the positive terminal of the battery must be sized to supply at least 125% of the maximum operating current and **FUSED** at the battery to carry that load. **DO NOT USE CIRCUIT BREAKERS WITH THIS PRODUCT!**

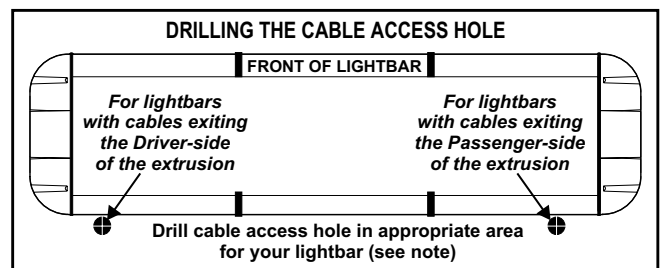

### Power Cable:

1. Open the wiring shield lid (Fig. 4) and route the power cable into the wiring shield and towards the firewall.
2. Follow the factory wiring harness through the firewall. It may be necessary to drill a hole in the firewall. If so, be absolutely sure that there are no components that could be damaged by drilling. After the hole has been drilled, insert a grommet to protect the cable.
3. Route the cable along the factory wiring harness towards the battery.
4. Install a 40 amp fuse block (customer supplied) on the end of the RED wire in the power cable. Remove the fuse from the fuse block before connecting any wires to the battery.

5. Connect the fuse block to the POSITIVE (+) terminal on the battery. There can not be more than two (2) feet of wire between the fuse block and the battery. The wire between the fuse block and the battery is "unprotected", do not allow this wire to come into contact with any other wires.
6. Connect the BLACK wire to the factory chassis ground near the battery.

**Control Cable:**

Extend the control cable to your switch panel and make the appropriate connections, using the information provided on page 4. *When you apply +12 VDC to a Control Cable wire, you activate its function.* The control cable connects to your control head or switch box and is fused there. Typical fusing is 5 Amps.

**Note:**The wire functions listed in this manual are the factory default settings for a fully loaded lightbar. To find the correct wire functions for the lightbar you ordered, refer to the switch operations sheet included.

**Low Power / VIOLET**

The type of switch used depends on how the operator wishes Hi/Lo to function:

**Latching Mode / Momentary Switch:** By applying +12 VDC voltage to the VIOLET wire for less than 1 sec., the power supply is "latched" into low power operation. Turn the unit off and back on to restore normal operation.

**Level Mode / Toggle Switch -** Applying +12 VDC voltage to the VIOLET wire for over 1 sec. holds the power supply in low power until voltage is removed.

**ScanLock™ / WHT/BLU or WHT VIO**

The ScanLock™ wire changes the flash patterns displayed by the lighthoods. To use ScanLock™ you must activate the lighthoods you wish to change. WHITE-BLUE is the ScanLock™ wire that changes the Strobe Lights and WHITE-VIOLET is the ScanLock™ wire that changes the LEDs.

**To cycle forward through all patterns:** Activate the lighthoods you want to change, then apply +12 volts to the appropriate ScanLock™ wire for less than 1 second and release. This will change the pattern. Repeat to go to next pattern.

**To choose a pattern:** While cycling through the patterns, when you find the pattern you want let it run for more than 5 seconds and it will lock in and become the default pattern.

**To reset to the factory default pattern:** Turn off the option you want to reset, apply +12 volts to the ScanLock™ wire then turn the option back on.

Listed here are the available flash patterns for your Strobes and Flashers. You will notice with the "Flasher" patterns that when you change the front pattern, the rear pattern also changes. They can not be programmed separately.

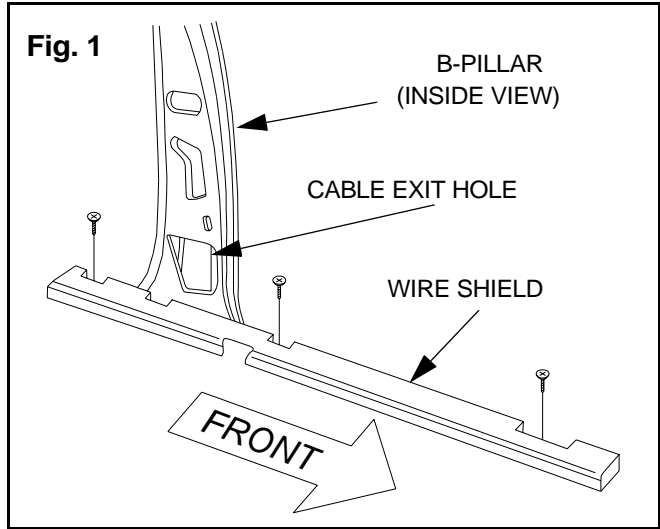

**Flasher Scan-Lock™ Patterns**

The REAR of the lightbar flashes: the lightbar flashes:

- SingleFlash 200 . . . . . SingleFlash 300
- DoubleFlash 120 . . . . . SingleFlash 300
- SingleFlash 300 . . . . . SingleFlash 300
- DoubleFlash 120 . . . . . SingleFlash 200
- SingleFlash 200 . . . . . SingleFlash 200
- DoubleFlash 120 . . . . . DoubleFlash 120
- SignalAlert™ 150 . . . . . SignalAlert™ 150
- DoubleFlash 120 . . . . . SignalAlert™ 150
- SingleFlash 200 . . . . . SignalAlert™ 150
- SingleFlash 300 . . . . . SignalAlert™ 150
- CometFlash® 150 . . . . . CometFlash® 150
- CometFlash® 150 . . . . . SingleFlash 375
- SingleFlash 375 . . . . . SingleFlash 375
- SingleFlash 375 . . . . . SingleFlash 75
- SingleFlash 75 . . . . . SingleFlash 75

**Strobe Scan-Lock™ Patterns**

- CometFlash® 150
- TripleFlash 185
- DoubleFlash 220
- SingleFlash 480
- ActionFlash™
- ModuFlash™
- MicroBurst 2™
- MicroBurst 3™
- LongBurst™
- ActionScan™

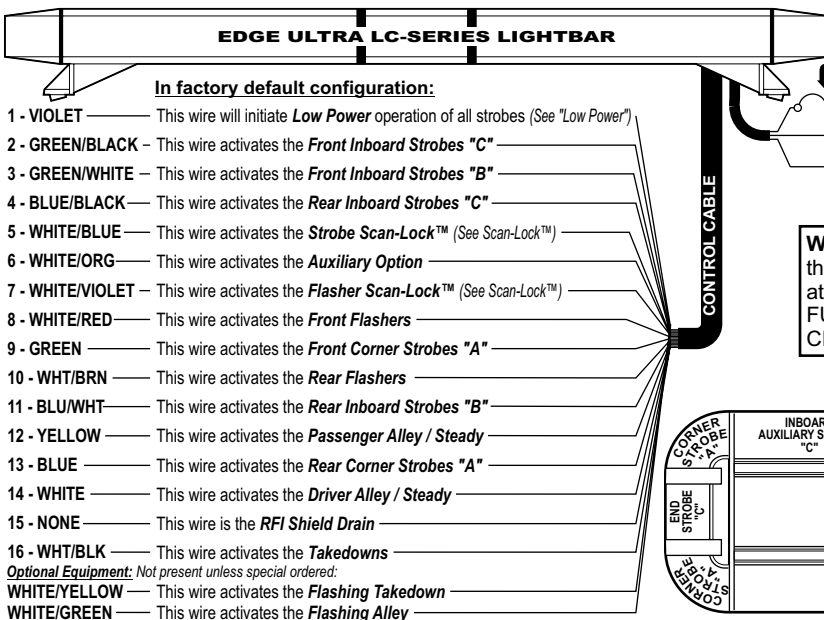

Fuse @ 40 amps for a fully loaded lightbar  
 POWER CABLE  
 RED - +12 VDC/8 AWG  
 BLACK - Ground/8 AWG  
 NONE - RFI Shield Drain

Applying +12 VDC to a control wire will enable that wires function.  
**IMPORTANT:** The proper fusing of the control wires, is explained under "Control Cable".

**WARNING:** All Customer supplied wires that connect to the positive terminal of the battery, must be sized to supply at least 125% of the maximum operating current and be FUSED at the battery to carry the load. DO NOT USE CIRCUIT BREAKERS WITH THIS PRODUCT!

