

WHELEN[®]

ENGINEERING COMPANY INC.

Route 145, Winthrop Road,
Chester, Connecticut 06412

Phone: (860) 526-9504

Fax: (860) 525-4078

Internet: www.whelen.com

Sales e-mail: autosale@whelen.com

Canadian Sales e-mail: autocan@whelen.com

Customer Service e-mail: custserv@whelen.com

Operating Guide: MPC02 Multi-Purpose Controller

Automotive: Serial Communication

Safety First

This document provides all the necessary information to allow your Whelen product to be properly and safely installed. Before beginning the installation and/or operation of your new product, the installation technician and operator must read this manual completely. Important information is contained herein that could prevent serious injury or damage.

- **Proper installation of this product requires the installer to have a good understanding of automotive electronics, systems and procedures.**
- **If mounting this product requires drilling holes, the installer MUST be sure that no vehicle components or other vital parts could be damaged by the drilling process. Check both sides of the mounting surface before drilling begins. Also de-burr any holes and remove any metal shards or remnants. Install grommets into all wire passage holes.**
- **If this manual states that this product may be mounted with suction cups, magnets, tape or Velcro™, clean the mounting surface with a 50/50 mix of isopropyl alcohol and water and dry thoroughly.**
- **Do not install this product or route any wires in the deployment area of your air bag. Equipment mounted or located in the air bag deployment area will damage or reduce the effectiveness of the air bag, or become a projectile that could cause serious personal injury or death. Refer to your vehicle owners manual for the air bag deployment area. The User/Installer assumes full responsibility to determine proper mounting location, based on providing ultimate safety to all passengers inside the vehicle.**
- **For this product to operate at optimum efficiency, a good electrical connection to chassis ground must be made. The recommended procedure requires the product ground wire to be connected directly to the NEGATIVE (-) battery post.**
- **If this product uses a remote device to activate or control this product, make sure that this device is located in an area that allows both the vehicle and the device to be operated safely in any driving condition.**
- **Do not attempt to activate or control this device in a hazardous driving situation.**
- **If this product contains strobe light(s), halogen light(s) or high-intensity LEDs, do not stare directly into these lights. Momentary blindness and/or eye damage could result.**
- **Use only soap and water to clean the outer lens. Use of other chemicals could result in premature lens cracking (crazing) and discoloration. Lenses in this condition have significantly reduced effectiveness and should be replaced immediately. Inspect and operate this product regularly to confirm its proper operation and mounting condition. Do not use a pressure washer to clean this product.**
- **It is recommended that these instructions be stored in a safe place and referred to when performing maintenance and/or reinstallation of this product.**
- **FAILURE TO FOLLOW THESE SAFETY PRECAUTIONS AND INSTRUCTIONS COULD RESULT IN DAMAGE TO THE PRODUCT OR VEHICLE AND/OR SERIOUS INJURY TO YOU AND YOUR PASSENGERS!**

For warranty information regarding this product, visit www.whelen.com/warranty

IMPORTANT!!!

Be sure to not only read this entire manual but also SAVE this and all Serial Communication manuals. They contain important data that may need to be referenced in the future. Consider storing these manuals in a 3-ring binder for easy referencing.

The MPC02, although technologically advanced, is simple to install. An aftermarket center console is recommended for the mounting location of the MPC02. This not only allows the driver to reach the MPC02 easily, but also keeps the MPC02 safely out of the path of the vehicle's SRS air-bag. Follow the console manufacturer's instructions for mounting information. The following steps will guide you through the installation process. This manual is written with the assumption that the MPC02 Multi-Purpose Controller and BLDISTI Power Distribution Center have already been installed and wired in your vehicle.

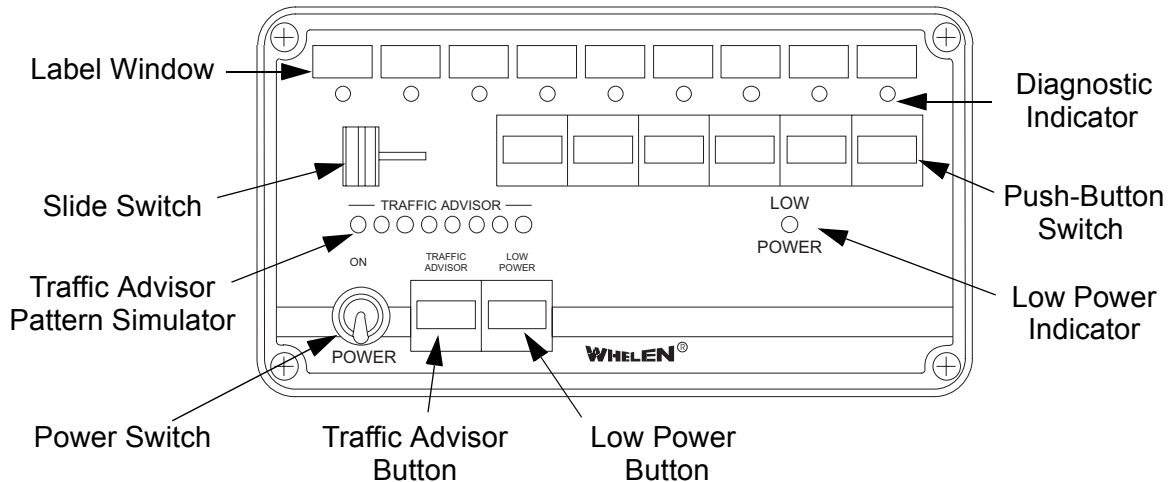

Section 1: The MPC02 Controls

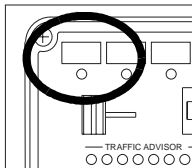

Label Window -

The label window displays the names of the configurations for a specific switch or button (called controls). There are 9 label windows, one for each of the 9 controls. The label windows are backlit and are illuminated when the dashboard lights are turned on (via the vehicle's dashlight dimmer switch).

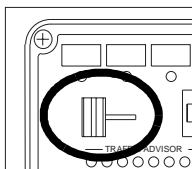

Slide Switch -

The first 3 of the 9 controls are selected with the Slide Switch. The slide switch has 4 positions:

Position #0 (farthest to the left) - This is an OFF position. When the slide switch is in this position, none of the programmed functions of the remaining 3 positions are active.

Position #1 (one detent to the right of the OFF position) - When the slide switch is in this position, the programmed function for this position is active. To de-activate position #1 functions, move the slide switch all the way to the left (Position #0).

Position #2 (two detents to the right of the OFF position) - When the slide switch is in this position, the programmed function for this position is active. To de-activate position #2 functions, move the slide switch all the way to the left (Position #0).

Position #3 (three detents to the right of the OFF position) - When the slide switch is in this position, the programmed function for this position is active. To de-activate position #3 functions, move the slide switch all the way to the left (Position #0).

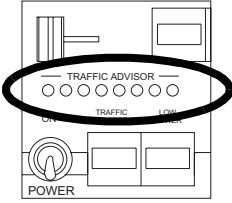

Traffic Advisor Pattern Simulator-

If the vehicle is equipped with a Whelen Traffic Advisor, the Traffic Advisor pattern simulator displays the currently selected Traffic Advisor flash sequence (e.g.: If the Traffic Advisor is a flash-to-left pattern, the pattern simulator will sequentially flash from right to left).

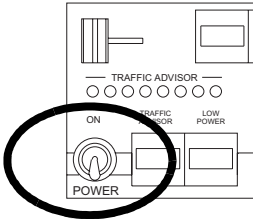

Power Switch -

This switch has 2 positions: Down (MPC02 Off) and Up (MPC02 On). When this switch is in the Off position, the entire network is inoperative and none of the installed serial communication components will function. When the switch is in the 'On' position, all of the components are functional and may be activated at the operator's discretion.

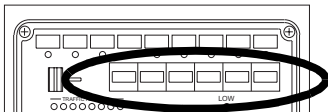

Push-button Switches -

The push-button switches activate specific, pre-programmed functions of the serial communications network. These 6 buttons are referred to as controls 4 (furthest button to the left) through 9 (furthest button to the right). Refer to the **Slide Switch** section for information on the first 3 controls. If you are not sure exactly how each control is configured, the configuration report, included with the MPC02, details the customized functions for each control.

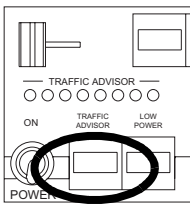

Traffic Advisor Control

This button is designated to control Traffic Advisor functions, if the vehicle is equipped with a Traffic Advisor. There are 4 patterns that are pre-programmed by the factory. Although specific patterns can be configured at the customer's request, the basic, non-custom patterns are described here for example purposes:

- | | |
|--------------------------------------|--------------------------|
| Press Control 8 | Sequence to Left |
| Press Control 8 a second time | Sequence to Right |
| Press Control 8 a third time | Split Pattern |
| Press Control 8 a fourth time | Flashing Pattern |

To terminate Traffic Advisor operation, press and hold the Traffic Advisor button.

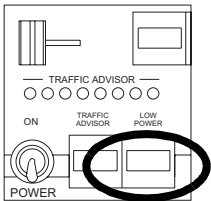

Low Power Activation Control

Pressing this button once, initiates low-intensity light operation. When the low-power mode has been activated, the diagnostic indicator on the MPC02 lights up to inform the operator that the low-power operation mode is active. Pressing Low Power a second time, returns the system to normal, full power operation. It is also the Si-Test™ initiation button. Refer to the Si-Test™ section for information on this feature.

Si-Test™ -

When Si-Test™ is activated, the MPC02 polls each installed serial communication component and confirms it's operating status. To initiate a Si-Test™, press and hold Lo Power for at least 5 seconds. As each component is tested, it's diagnostic indicator will turn on if there is no problem detected, or flash if a failure has been detected. If enabled by the factory or a factory authorized representative, a series of 3, separate alarm tones will be heard from the MPC02 whenever a failure has been detected.

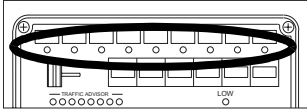

Diagnostic Indicator -

There are 9 diagnostic indicators; one for each of the 9 controls. Below each Label Window, there is a diagnostic indicator that is programmed to monitor the operation of that window's control. When a diagnostic indicator lamp is on, all of the programmed functions for that control are functioning properly. If a diagnostic indicator is flashing, one or more of the components being monitored are not functioning. If enabled by the factory or a factory authorized representative, a series of 3, separate alarm tones will be heard from the MPC02 whenever a failure has been detected.

Section 2: Additional Features

The MPC02 has been designed to incorporate auxiliary input and output features into the serial communications network. Essentially, this enables the MPC02 to not only control non-network components, but to allow non-network components to activate specific network functions.

Auxiliary Input-

The MPC02 may be connected to 2, non-network components. This allows auxiliary switches, such as the vehicle's neutral safety switch, a K-9 thermostat or a burglar alarm, to activate a pre-programmed, network component. For example: When the interior temperature of the vehicle has exceeded the K-9 thermostat's pre-set level, the MPC02 will automatically activate a specific, K-9 alarm that will alert the operator to the situation. Refer to the diagram below for wiring details.

Auxiliary Output-

The MPC02 may be connected to 2, non-network components. This allows the MPC02 to control auxiliary relays, such as a gunlock. For example: Pushing control button 5 releases the vehicle's gunlock. Refer to the diagram below for wiring details.

J6-AUX. INPUT		
PIN #	COLOR	FUNCTION
1	BROWN	AUX IN 1
2	RED	AUX IN 2
3	ORANGE	AUX OUT 1
4	YELLOW	AUX OUT 2

J7-COMMUNICATION INPUT		
PIN #	COLOR	FUNCTION
1	BLUE	+RS485
2	GREY	-RS485
3	WHITE	NOT USED
4	BLACK	NOT USED
5	DRAIN	SHIELD

J8- POWER INPUT		
PIN #	COLOR	FUNCTION
1	RED	+V IN
2	BLACK	GROUND
3	YELLOW	BACK LIGHT
4	N/C	N/C
5	N/C	N/C
6	N/C	N/C
7	N/C	N/C

SPECIFICATIONS

V IN	13.2VDC 20%
I IN (STANDBY)	< 10mA
I IN (BACKLIGHT)	< 100mA
I IN (HORN)	5 AMPS (MAX)
V (HORNRING)	V IN OR GROUND
I (HORNRING)	10mA (MIN) 5 AMPS (MAX)

WIRING DIAGRAM

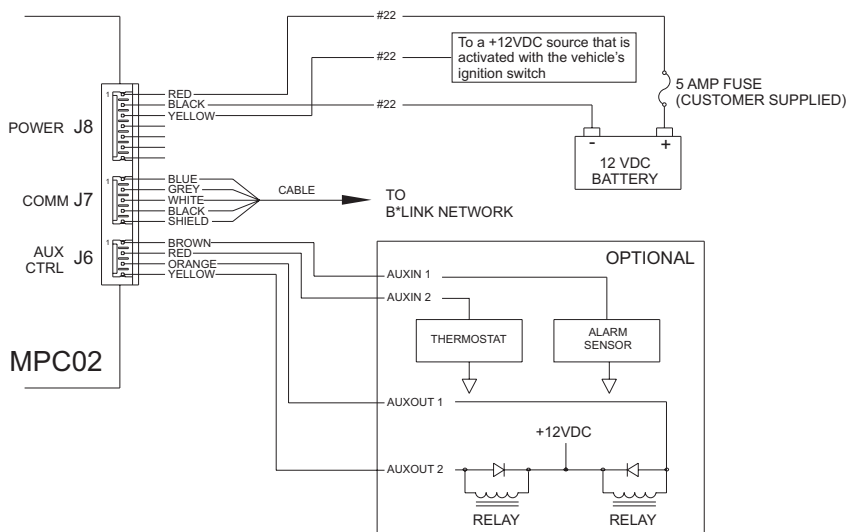

COMMUNICATIONS

RS485 — 9600 BPS

AUX. INPUT

AUX IN 1 (ENABLE) - < 1 VDC
 AUX IN 2 (ENABLE) - < 1 VDC
 AUX OUT 1 (ACTIVE) - < 1 VDC
 AUX OUT 2 (ACTIVE) - < 1 VDC