

WHELEN[®]

ENGINEERING COMPANY INC.

51 Winthrop Road,
Chester, Connecticut 06412-0684
Phone: (860) 526-9504
Fax: (860) 526-4078

Installation Guide: Edge[®] Ultra Endcap Gasket

Internet: www.whelen.com
Sales e-mail: autosale@whelen.com
Canadian Sales e-mail: autocan@whelen.com
Customer Service e-mail: custserv@whelen.com

IMPORTANT!

When installing or reinstalling the endcap gasket, mount the gasket onto the endcap so that it is oriented as shown below.

Use a torque wrench when tightening the endcap screws. Apply between 21 and 27 in/lbs of torque.

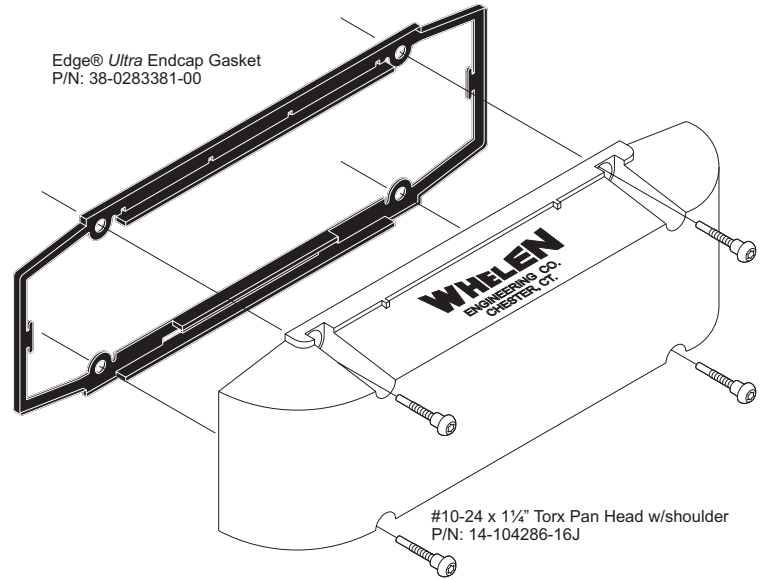

©2001 Whelen Engineering Company Inc.
Form No.13581A (060507)

For warranty information regarding this product, visit www.whelen.com/warranty

WHELEN[®]

ENGINEERING COMPANY INC.

51 Winthrop Road,
Chester, Connecticut 06412-0684
Phone: (860) 526-9504
Fax: (860) 526-4078

Installation Guide: Edge[®] Ultra Endcap Gasket

Internet: www.whelen.com
Sales e-mail: autosale@whelen.com
Canadian Sales e-mail: autocan@whelen.com
Customer Service e-mail: custserv@whelen.com

IMPORTANT!

When installing or reinstalling the endcap gasket, mount the gasket onto the endcap so that it is oriented as shown below.

Use a torque wrench when tightening the endcap screws. Apply between 21 and 27 in/lbs of torque.

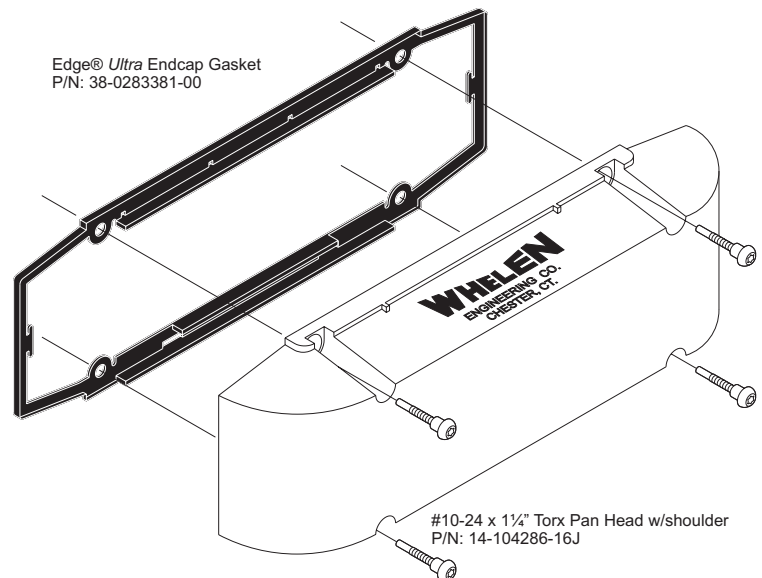

©2001 Whelen Engineering Company Inc.
Form No.13581A (060507)

For warranty information regarding this product, visit www.whelen.com/warranty