

WHELEN[®] ENGINEERING COMPANY INC.

51 Winthrop Road
 Chester, Connecticut 06412-0684
 Phone: (860) 526-9504
 Fax: (860) 526-4078
 Internet: www.whelen.com
 Sales e-mail: autosale@whelen.com
 Canadian Sales e-mail: autocan@whelen.com
 Customer Service e-mail: custserv@whelen.com

Installation Guide: Dual Underpro Siren Ford E-series Van & F-series Truck

DANGER! Sirens produces extremely loud emergency warning tones! Exposure to these tones without proper and adequate hearing protection, could cause ear damage and/or hearing loss! The Occupational Safety & Health Administration (www.osha.gov) provides information necessary to determine safe exposure times in Occupational Noise Exposure Section 1910.95. Until you have determined the safe exposure times for your specific application, operators and anyone else in the immediate vicinity should be required to wear an approved hearing protection device. **FAILURE TO FOLLOW THIS RECOMMENDATION COULD CAUSE HEARING LOSS!**

Safety First

This document provides all the necessary information to allow your Whelen product to be properly and safely installed. Before beginning the installation and/or operation of your new product, the installation technician and operator must read this manual completely. Important information is contained herein that could prevent serious injury or damage.

- Proper installation of this product requires the installer to have a good understanding of automotive electronics, systems and procedures.
- If mounting this product requires drilling holes, the installer **MUST** be sure that no vehicle components or other vital parts could be damaged by the drilling process. Check both sides of the mounting surface before drilling begins. Also de-burr any holes and remove any metal shards or remnants. Install grommets into all wire passage holes.
- If this manual states that this product may be mounted with suction cups, magnets, tape or Velcro™, clean the mounting surface with a 50/50 mix of isopropyl alcohol and water and dry thoroughly.
- Do not install this product or route any wires in the deployment area of your air bag. Equipment mounted or located in the air bag deployment area will damage or reduce the effectiveness of the air bag, or become a projectile that could cause serious personal injury or death. Refer to your vehicle owners manual for the air bag deployment area. The User/Installer assumes full responsibility to determine proper mounting location, based on providing ultimate safety to all passengers inside the vehicle.
- For this product to operate at optimum efficiency, a good electrical connection to chassis ground must be made. The recommended procedure requires the product ground wire to be connected directly to the **NEGATIVE (-)** battery post.
- If this product uses a remote device to activate or control this product, make sure this control is located in an area that allows both the vehicle and the control to be operated safely in any driving condition. **DO NOT ATTEMPT TO ACTIVATE OR CONTROL THIS DEVICE IN A HAZARDOUS DRIVING SITUATION.**
- It is recommended that these instructions be stored in a safe place and referred to when performing maintenance and/or reinstallation of this product.
- **FAILURE TO FOLLOW THESE SAFETY PRECAUTIONS AND INSTRUCTIONS COULD RESULT IN DAMAGE TO THE PRODUCT OR VEHICLE AND/OR SERIOUS INJURY TO YOU AND YOUR PASSENGERS!**

ACTIVATION OF THIS SIREN MAY DAMAGE UNPROTECTED EARS!



Wear Protection!

CAUTION

Loud siren noise can cause hearing damage and/or loss. Refer to OSHA Section 1910.95 prior to putting ANY siren into service!

For warranty information regarding this product, visit www.whelen.com/warranty

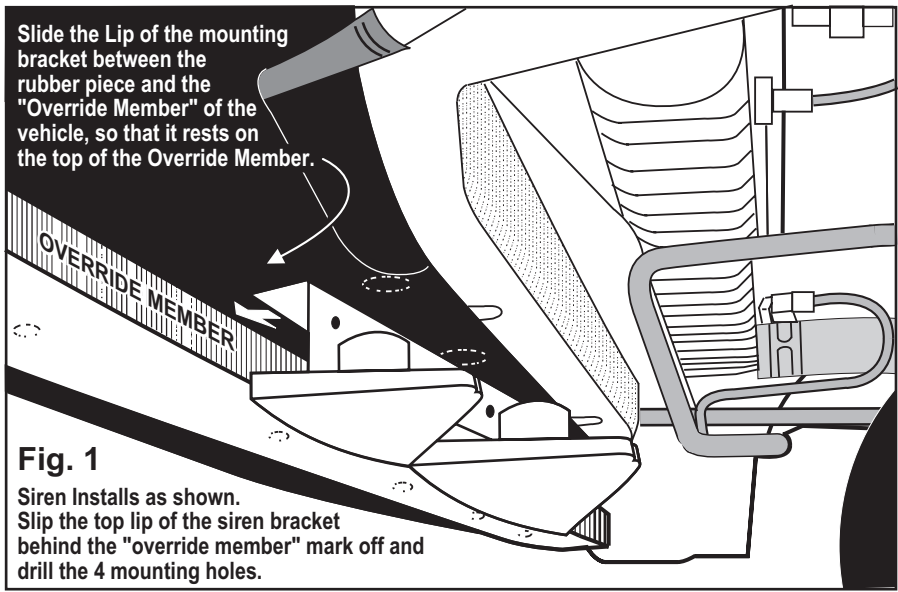

Fig. 1
Siren installs as shown. Slip the top lip of the siren bracket behind the "override member" mark off and drill the 4 mounting holes.

Installation / "F" Series Truck:

1. Locate the black rubber protective piece that attaches to the radiator support and runs up to the override member.
2. Slide the leading edge of the siren mounting brackets lip, between the top of the override member and this rubber piece. **NOTE:** The siren should be "centered" on the front of the vehicle.
3. With the bracket in place, mark off the location of the 4 mounting holes.
4. Drill the 4 mounting holes using a drill sized for the supplied "self tapping" mounting hardware. (5/16 - 18 X 1-1/4" HX WHR HD SELFTAP)
5. Mount the siren as shown.
6. Extend the siren wires to your siren amplifier and follow the amplifiers instructions for hookup.

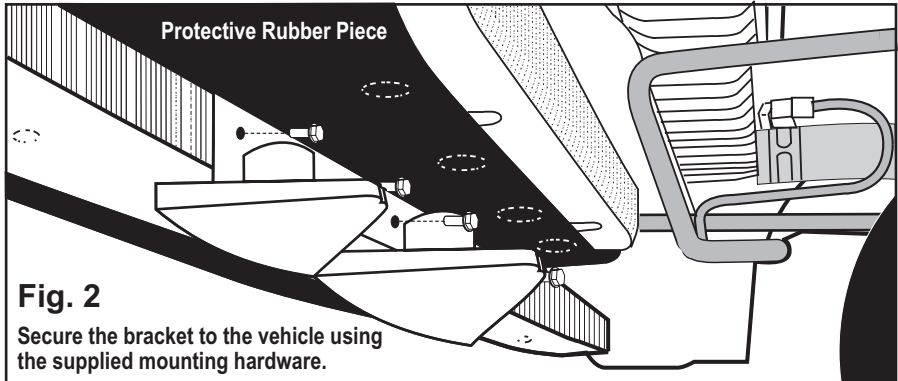

Fig. 2
Secure the bracket to the vehicle using the supplied mounting hardware.

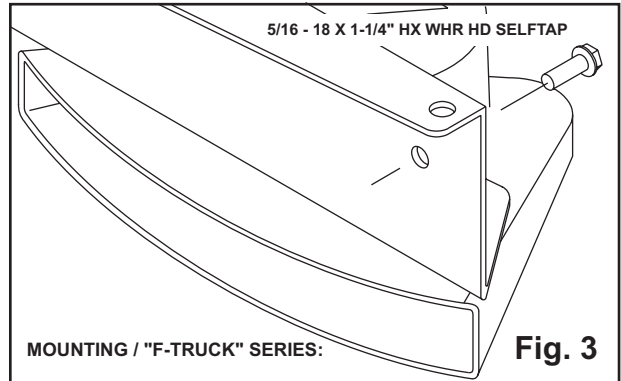

Fig. 3

Installation / "E" Series Van:

1. Locate the 4 pop rivets toward the front of the vehicle shown in Fig. 1.
2. Drill out the 4 rivets shown in Fig.2 to create clearance holes for the supplied mounting hardware.
3. Remove any extra pieces of rivet by reaching in through the front grill.
4. Install the mounting bracket using the supplied mounting hardware (Fig. 3 and Fig. 4).
5. Extend the siren wires to your siren amplifier and follow the amplifiers instructions for hookup.

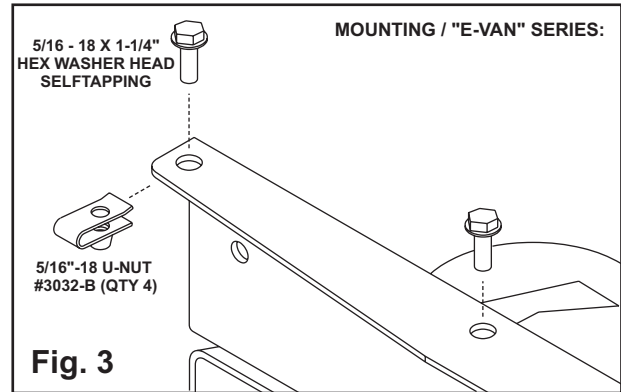
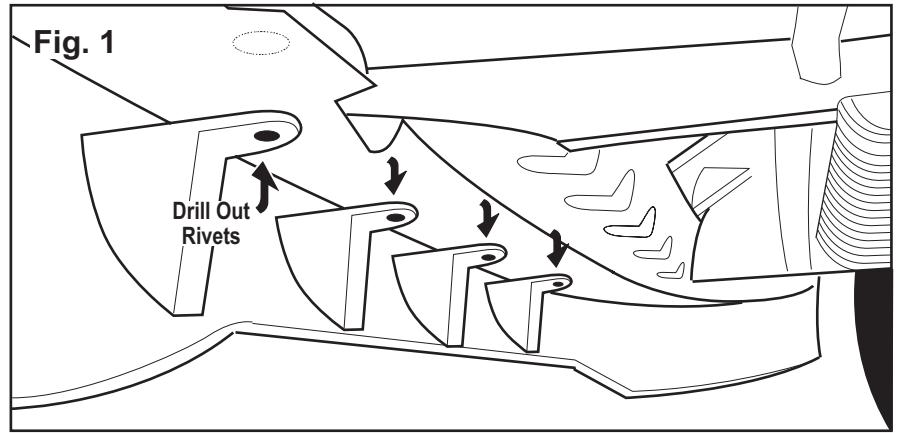

Fig. 3

