

WHELEN[®]

ENGINEERING COMPANY INC.

51 Winthrop Road
Chester, Connecticut 06412-0684
Phone: (860) 526-9504
Fax: (860) 526-4078
Internet: www.whelen.com
Sales e-mail: autosale@whelen.com
Canadian Sales e-mail: autocan@whelen.com
Customer Service e-mail: custserv@whelen.com

Installation Guide: Edge[®] Mini LFL 17.25" 4-Strobe Lightbar

Safety First

This document provides all the necessary information to allow your Whelen product to be properly and safely installed. Before beginning the installation and/or operation of your new product, the installation technician and operator must read this manual completely. Important information is contained herein that could prevent serious injury or damage.

- Proper installation of this product requires the installer to have a good understanding of automotive electronics, systems and procedures.
- If mounting this product requires drilling holes, the installer **MUST** be sure that no vehicle components or other vital parts could be damaged by the drilling process. Check both sides of the mounting surface before drilling begins. Also de-burr any holes and remove any metal shards or remnants. Install grommets into all wire passage holes.
- If this manual states that this product may be mounted with suction cups, magnets, tape or Velcro[®], clean the mounting surface with a 50/50 mix of isopropyl alcohol and water and dry thoroughly.
- Do not install this product or route any wires in the deployment area of your air bag. Equipment mounted or located in the air bag deployment area will damage or reduce the effectiveness of the air bag, or become a projectile that could cause serious personal injury or death. Refer to your vehicle owner's manual for the air bag deployment area. The User/Installer assumes full responsibility to determine proper mounting location, based on providing ultimate safety to all passengers inside the vehicle.
- For this product to operate at optimum efficiency, a good electrical connection to chassis ground must be made. The recommended procedure requires the product ground wire to be connected directly to the **NEGATIVE (-)** battery post.
- If this product uses a remote device to activate or control this product, make sure that this control is located in an area that allows both the vehicle and the control to be operated safely in any driving condition.
- Do not attempt to activate or control this device in a hazardous driving situation.
- This product contains either strobe light(s), halogen light(s), high-intensity LEDs or a combination of these lights. Do not stare directly into these lights. Momentary blindness and/or eye damage could result.
- Use only soap and water to clean the outer lens. Use of other chemicals could result in premature lens cracking (crazing) and discoloration. Lenses in this condition have significantly reduced effectiveness and should be replaced immediately. Inspect and operate this product regularly to confirm its proper operation and mounting condition. Do not use a pressure washer to clean this product.
- It is recommended that these instructions be stored in a safe place and referred to when performing maintenance and/or reinstallation of this product.
- **FAILURE TO FOLLOW THESE SAFETY PRECAUTIONS AND INSTRUCTIONS COULD RESULT IN DAMAGE TO THE PRODUCT OR VEHICLE AND/OR SERIOUS INJURY TO YOU AND YOUR PASSENGERS!**

For warranty information regarding this product, visit www.whelen.com/warranty

The Mini-LFL Lightbar MLFL17M* and MLFL22M* cigar plug models are wired at the factory and come ready to plug into your vehicle's cigar lighter 12-volt port. The MLFL17P* and MLFL22P* Permanent mount models come with a 4 conductor cable. Refer to the wiring diagram for connection. Refer to the mounting guide included with your lightbar for permanent mounting information.

IMPORTANT! The lightbar should be located a minimum of 16" from any radio antennas!

Magnetic Mount Warning!

THE USE OF ANY MAGNETICALLY MOUNTED WARNING DEVICE ON THE OUTSIDE OF A VEHICLE IN MOTION IS NOT RECOMMENDED AND IS THE SOLE RISK AND RESPONSIBILITY OF THE USER.

Wiring:

Hi/Low Control (GREEN)

The type of switch used is dependant on how the operator wishes the Hi/Lo feature to function:

Option 1: Latching Mode: By applying +voltage to the GREEN wire for less than 1 sec., the power supply is "latched" into low power operation. The unit must be turned off and then back on to restore normal, Hi power operation. A momentary switch is desired for this.

Option 2: Level Mode: Applying +voltage to the GREEN wire for more than 1 sec. holds the power supply in low power mode until that voltage is removed. A toggle switch is desired for this.

Scan-Lock™

TO CYCLE FORWARD THROUGH ALL PATTERNS: Apply +12 volts to the WHITE wire for less than 1 second and release. This will change the pattern. Repeat to go to next pattern.

TO CHOOSE A PATTERN: While cycling through the patterns, when you find the pattern you want, let it run for more than 5 seconds and it will lock in and become the default pattern.

TO RESET TO THE FACTORY DEFAULT PATTERN: Turn off power, apply +12 volts to the WHITE wire, then turn power back on.

| QTY | QTY | ITEM | PART NUMBER | DESCRIPTION |
|-----|-----|------|----------------|--|
| | * | | 01-0683623-00 | LIGHTBAR ASS'Y. with CIGAR PLUG / MINI "LFL" |
| | * | | 01-0683623-01 | LIGHTBAR ASS'Y. with 4C CABLE / MINI "LFL" |
| 1 | 1 | 1 | 11-363351-012 | BASE EXTRUSION |
| - | 4 | 2 | 08-0640834-01 | MOUNTING PAD |
| - | 4 | 3 | 65-0010192-00 | MAGNET X-80 |
| - | 4 | 4 | | 1/4-20 x 5/8" PPHMS |
| - | A/R | 5 | 66-0715403-00 | LOCTITE 242 THREADLOCKER (Not Shown) |
| - | 1 | 6 | 02-0240837-01 | INPUT CABLE ASS'Y. with CIGAR PLUG |
| 1 | 1 | 8 | 21-11101612-00 | 1/2" GROMMET |
| 2 | 2 | 9 | 26-0215001-06 | 6" TY-WRAP |
| 1 | 1 | 10 | 39-0408323-04 | 8 SOCKET CONNECTOR |
| 1 | 1 | 11 | 01-0269098-00 | LFL412 POWER SUPPLY ASS'Y. |
| - | 1 | 12 | 46-0763354-00 | POWER INPUT HARNESS (Not Shown) |
| 1 | 1 | 13 | 46-0763355-00 | STROBE OUTPUT HARNESS ASS'Y. |
| 4 | 4 | 14 | 02-0363332-00 | CORNER STROBE |
| A/R | A/R | 15 | 68-3163296-20 | CORNER STROBE LENS / BLUE |

| QTY | QTY | ITEM | PART NUMBER | DESCRIPTION |
|-----|-----|------|---------------|--|
| | * | | 01-0683623-00 | LIGHTBAR ASS'Y. with CIGAR PLUG / MINI "LFL" |
| | * | | 01-0683623-01 | LIGHTBAR ASS'Y. with 4C CABLE / MINI "LFL" |
| A/R | A/R | 16 | | #4 x 3/8" PPH PLASTI-LOC |
| 1 | 1 | 17 | 11-263352-012 | TOP EXTRUSION |
| 2 | 2 | 18 | 02-0342791-00 | LENS DIVIDER |
| 4 | 4 | 19 | 68-1963333B04 | 6-5/32" LENS / BLUE |
| 2 | 2 | 20 | 38-0283572-00 | ENDCAP GASKET |
| 4 | 4 | 21 | | #6-32 x 5/8" PPHMS |
| 2 | 2 | 22 | 68-1963237-20 | 500 SERIES OPTIC LENS / BLUE |
| 2 | 2 | 23 | 68-1183566-2S | ENDCAP LENS / BLUE / with SEAL |
| 4 | 4 | 24 | 13-062120-052 | #6-32 ELASTIC STOP NUT |
| 8 | 8 | 25 | 14-104286-16J | #10-24 x 1-1/4" TX. PHD. with SHOULDER |
| 2 | 2 | 27 | 15-105A76-168 | #10 x 1" TX. 100° FH PLASTI-LOC W/SEAL |
| 1 | - | 28 | 01-048328407S | MOUNTING KIT 7S / CENTURION |
| 1 | - | 29 | 46-0763379-00 | POWER INPUT / 4C INPUT HARNESS |
| 1 | - | 30 | 02-0241912-01 | INPUT CABLE ASS'Y. / 4C |

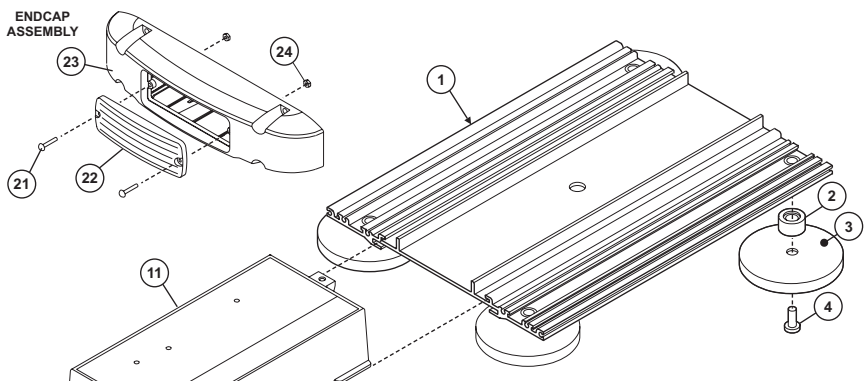
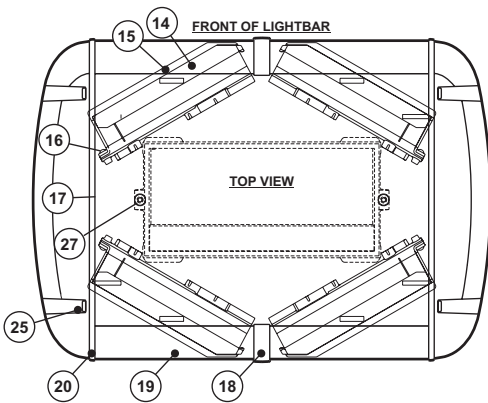

WARNING!
 All customer supplied wires that connect to the positive terminal of the battery must be sized to supply at least 125% of the maximum operating current and FUSED at the battery to carry that load. DO NOT USE CIRCUIT BREAKERS WITH THIS PRODUCT!

