

# WHELEN<sup>®</sup>

ENGINEERING COMPANY INC.

Route 145, Winthrop Road,

Chester, Connecticut 06412

Phone: (860) 526-9504

Fax: (860) 526-4078

Internet: [www.whelen.com](http://www.whelen.com)

Sales e-mail: [autosale@whelen.com](mailto:autosale@whelen.com)

Canadian Sales e-mail: [autocan@whelen.com](mailto:autocan@whelen.com)

Customer Service e-mail: [custserv@whelen.com](mailto:custserv@whelen.com)

## Installation Manual: Model 508 Series Stop / Tail / Turn / Lighthouse

### Safety First

This document provides all the necessary information to allow your Whelen product to be properly and safely installed. Before beginning the installation and/or operation of your new product, the installation technician and operator must read this manual completely. Important information is contained herein that could prevent serious injury or damage.

- **Proper installation of this product requires the installer to have a good understanding of automotive electronics, systems and procedures.**
- **If mounting this product requires drilling holes, the installer MUST be sure that no vehicle components or other vital parts could be damaged by the drilling process. Check both sides of the mounting surface before drilling begins. Also de-burr any holes and remove any metal shards or remnants. Install grommets into all wire passage holes.**
- **If this product is mounted with tape or Velcro™, clean the mounting surface with a 50/50 mix of isopropyl alcohol and water and dry thoroughly.**
- **Do not install this product or route any wires in the deployment area of your air bag. Equipment mounted or located in the air bag deployment area will damage or reduce the effectiveness of the air bag, or become a projectile that could cause serious personal injury or death. Refer to your vehicle owners manual for the air bag deployment area. The User/Installer assumes full responsibility to determine proper mounting location, based on providing ultimate safety to all passengers inside the vehicle.**
- **For this product to operate at optimum efficiency, a good electrical connection to chassis ground must be made. The recommended procedure requires the product ground wire to be connected directly to the NEGATIVE (-) battery post.**
- **If this product uses a remote device to activate or control this product, make sure that this control is located in an area that allows both the vehicle and the control to be operated safely in any driving condition.**
- **Do not attempt to activate or control this device in a hazardous driving situation.**
- **This product contains either strobe light(s), halogen light(s), high-intensity LEDs or a combination of these lights. Do not stare directly into these lights. Momentary blindness and/or eye damage could result.**
- **Use only soap and water to clean the outer lens. Use of other chemicals could result in premature lens cracking (crazing) and discoloration. Lenses in this condition have significantly reduced effectiveness and should be replaced immediately. Inspect and operate this product regularly to confirm its proper operation and mounting condition. Do not use a pressure washer to clean this product.**
- **It is recommended that these instructions be stored in a safe place and referred to when performing maintenance and/or reinstallation of this product.**
- **FAILURE TO FOLLOW THESE SAFETY PRECAUTIONS AND INSTRUCTIONS COULD RESULT IN DAMAGE TO THE PRODUCT OR VEHICLE AND/OR SERIOUS INJURY TO YOU AND YOUR PASSENGERS!**

## Installation:

There are two ways to mount the 508 lighthouse, each offering its own benefits:

- Secured to the vehicle using the supplied sheet metal screws.
- Secured to the vehicle using an industry-strength, double-sided adhesive tape, like Scotch™ brand VHB™ model 4956 foam tape.

This manual will outline the first procedure:

1. Remove the lenses and position the reflector assembly on its mounting location. Make sure that the 508 will not interfere with any existing equipment. Also be aware of all items on the opposite side of the mounting surface to prevent any possible damage to existing components.
2. With the reflector assembly positioned on the mounting location, temporarily secure it to the surface with masking tape. Be sure the reflector assembly is FLAT against the surface.

3. Mark the 4 mounting holes and the 1 wire access holes using the reflector as a template. (See below)
4. Now remove the reflector and drill the mounting holes with an appropriately sized drill.
5. It is a good idea to deburr the wire holes and install a rubber grommet (customer supplied) to protect the wires.

**WARNING! All customer supplied wires that connect to the positive (+) terminal of the battery, must be sized to supply atleast 125% of the maximum operating current, and fused "at the battery" to carry that load.**

6. Wire the light using the wiring diagram on the next page.
7. Mount lenses onto reflector and secure with supplied lens screws.

**Note: When mounting the lenses make sure the drain hole is on the bottom. Be sure the gaskets drain hole is also mounted on the bottom. Each gasket is labeled.**

## Mounting Dimensions / This is Not a Template

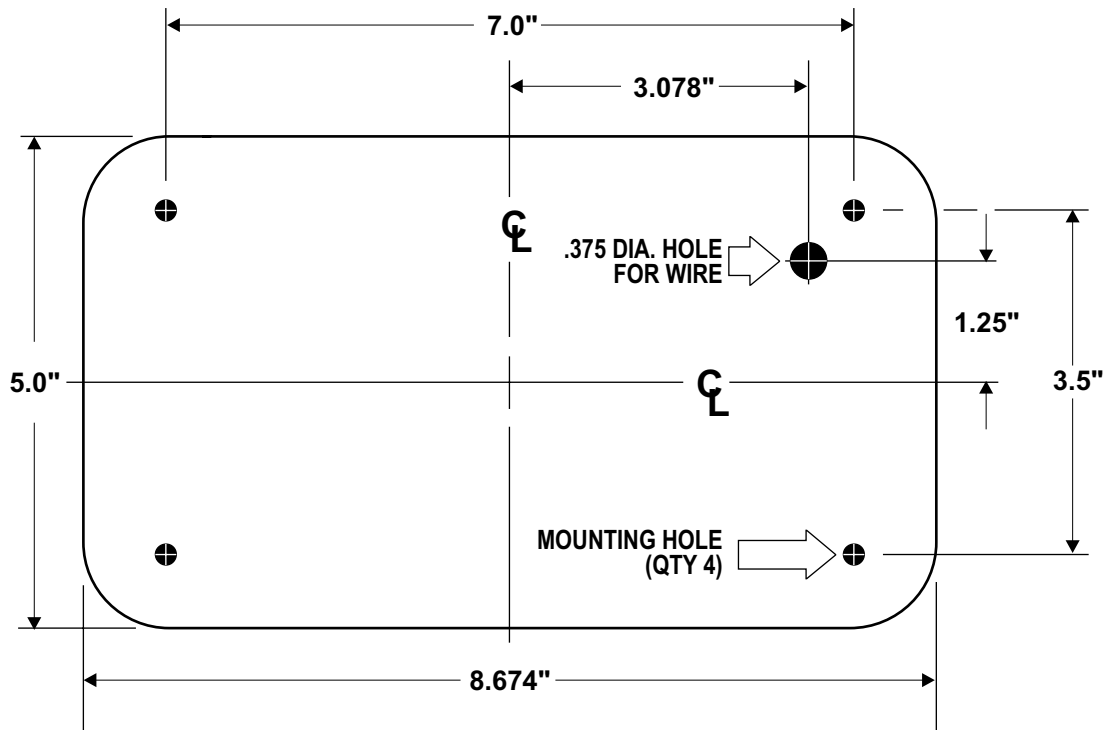

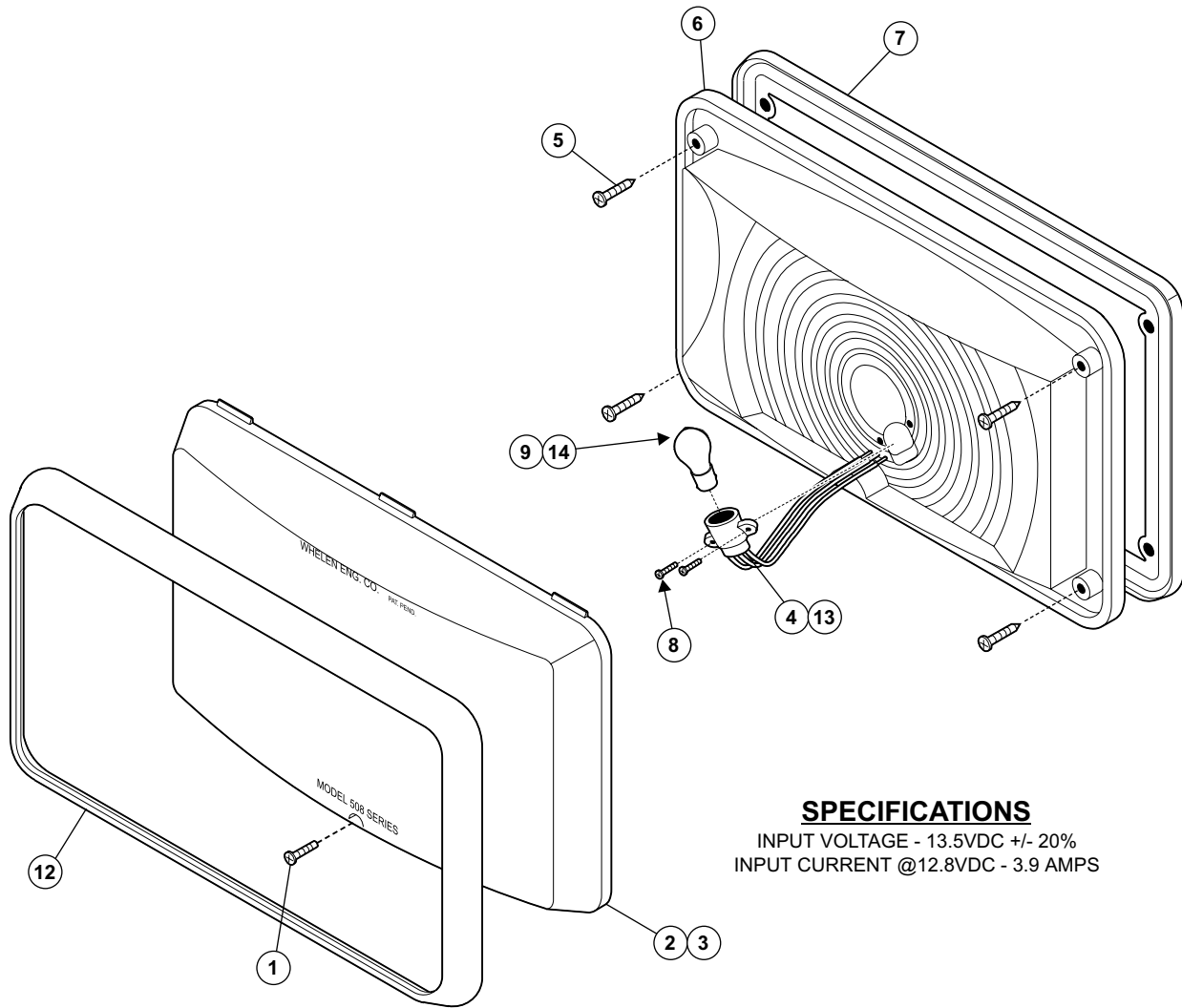

**SPECIFICATIONS**  
 INPUT VOLTAGE - 13.5VDC +/- 20%  
 INPUT CURRENT @12.8VDC - 3.9 AMPS

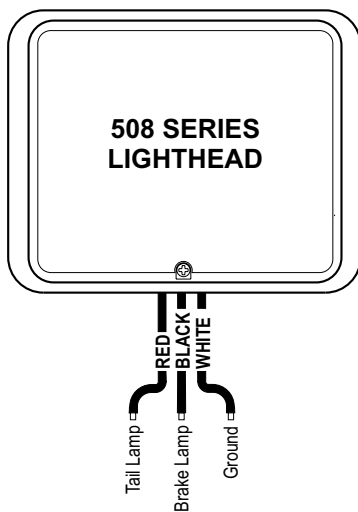

**MODEL 508 SERIES HALOGEN STOP/TAIL/TURN LIGHT**

QTY	ITEM	PART NUMBER	DESCRIPTION
*	*	01-0682669( )	MODEL 508 SERIES / HALOGEN STOP-TAIL-TURN LIGHT
1	1	14-082216-080	8-32 X 1/2 PPHMS SS
A/R	2	68-1182419-10	LENS / AMBER
A/R	3	68-1182419-50	LENS / RED
A/R	4	33-0042149-00	DUAL FILAMENT LAMP HOLDER ASS'Y
4	5	15-101416-160	#10 x 1" PPHSMS
1	6	68-5982458-02	DIRECTIONAL REFLECTOR METALIZED with SEAL
1	7	38-0462719-00	REFLECTOR GASKET
2	8	15-065419-070	#6x7/16" PPH PLASTI-LOK
A/R	9	34-0062389-00	LAMP ASS'Y 12.8V-14V / 27-12WATT HOR. DUAL FIL.
A/R	10	66-0422788-03	VHB 3" TAPE / NOT SHOWN
A/R	11	66-0422788-04	VHB 4" TAPE / NOT SHOWN
A/R	12	11-783516-002	FLANGE COVER
A/R	13	33-0042822-00	LAMPHOLDER ASSY / BAYONET DUAL FILAMENT
A/R	14	33-0021562-00	LAMP / STOP-TAIL-TURN

**PART NUMBER KEY:**  
 BASIC P/N LAMP COLOR FLANGE

01-0682669

LAMP: - = SNAP-IN  
 1 = BAYONET

FLANGE: 0 = without CHROME COVER  
 1 = with CHROME COVER

COLOR: A = AMBER  
 R = RED