

# WHELEN<sup>®</sup>

ENGINEERING COMPANY INC.

Route 145, Winthrop Road,

Chester, Connecticut 06412

Phone: (860) 526-9504

Fax: (860) 526-4078

Internet: [www.whelen.com](http://www.whelen.com)

Sales e-mail: [autosale@whelen.com](mailto:autosale@whelen.com)

Canadian Sales e-mail: [autocan@whelen.com](mailto:autocan@whelen.com)

Customer Service e-mail: [custserv@whelen.com](mailto:custserv@whelen.com)

## Installation Guide UHFGND Headlight Flasher (Negative Switching)

### Safety First

This document provides all the necessary information to allow your Whelen product to be properly and safely installed. Before beginning the installation and/or operation of your new product, the installation technician and operator must read this manual completely. Important information is contained herein that could prevent serious injury or damage.

- **Proper installation of this product requires the installer to have a good understanding of automotive electronics, systems and procedures.**
- **If mounting this product requires drilling holes, the installer MUST be sure that no vehicle components or other vital parts could be damaged by the drilling process. Check both sides of the mounting surface before drilling begins. Also de-burr any holes and remove any metal shards or remnants. Install grommets into all wire passage holes.**
- **If this product is mounted with tape or Velcro™, clean the mounting surface with a 50/50 mix of isopropyl alcohol and water and dry thoroughly.**
- **Do not install this product or route any wires in the deployment area of your air bag. Equipment mounted or located in the air bag deployment area will damage or reduce the effectiveness of the air bag, or become a projectile that could cause serious personal injury or death. Refer to your vehicle owners manual for the air bag deployment area. The User/Installer assumes full responsibility to determine proper mounting location, based on providing ultimate safety to all passengers inside the vehicle.**
- **For this product to operate at optimum efficiency, a good electrical connection to chassis ground must be made. The recommended procedure requires the product ground wire to be connected directly to the NEGATIVE (-) battery post.**
- **If this product uses a remote device to activate or control this product, make sure that this control is located in an area that allows both the vehicle and the control to be operated safely in any driving condition.**
- **Do not attempt to activate or control this device in a hazardous driving situation.**
- **It is recommended that these instructions be stored in a safe place and referred to when performing maintenance and/or reinstallation of this product.**
- **FAILURE TO FOLLOW THESE SAFETY PRECAUTIONS AND INSTRUCTIONS COULD RESULT IN DAMAGE TO THE PRODUCT OR VEHICLE AND/OR SERIOUS INJURY TO YOU AND YOUR PASSENGERS!**

## IMPORTANT NOTES!

- The use of a flashing headlight system may be regulated by state, county, or municipal authorities. It is the responsibility of the end user to comply with these regulations.
- The installation of a headlight flasher system requires a modification to the standard headlight wiring harness. This modification may effect the warranty of your vehicle. It is the responsibility of the end user to verify the warranty conditions with the vehicle manufacturer. Also, the use of a headlight flasher may shorten the high beam bulb life.
- Before attempting the installation of the UHFGNDC headlight flasher, thoroughly read and understand instructions and steps shown below!
- Disconnect the battery from the electrical system before attempting any part of this installation!
- All customer supplied wires that connect to the positive (+) terminal of the battery, must be sized to supply at least 125% of the maximum operating current, and be fused "at the battery" to carry that load.

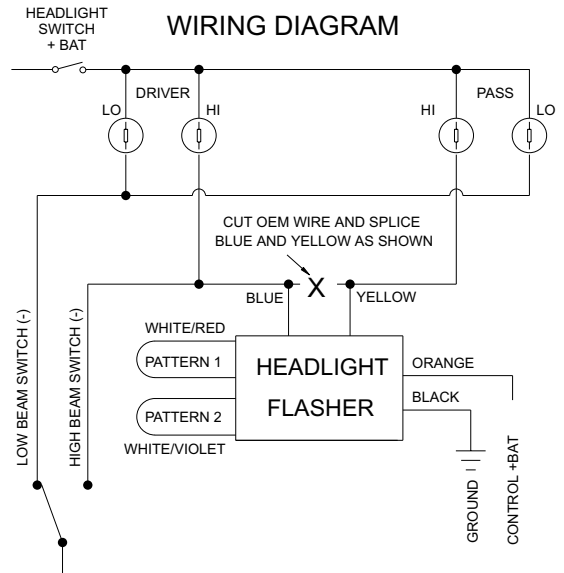

## Installation

There are two different switching methods used to activate the headlight/parking lights in a motor vehicle; **Positive-Side** Switching and **Ground-Side** Switching. For example, the headlights may use Ground-Side switching, while the parking lights may use Positive-Side switching. **This product is designed for use only with GROUND-Side headlight switching!** Before installing this product, it will be necessary to contact the vehicle manufacturer to confirm that the vehicle in question uses Ground-Side headlight switching.

1. Mount the UHFGND in the engine compartment near the battery and headlights. DO NOT mount the unit directly on the engine or close to the exhaust system.
2. Connect the UHFGND wires to the vehicle as outlined here.
  - BLACK** - Connect to the vehicle's chassis ground.
  - BLUE** - Connect to the end of the cut wire from the driver-side high beam headlight (see wiring diagram). This BLUE wire may be extended using 14 AWG wire.
  - YELLOW** - Connect to the end of the cut wire from the passenger-side high beam headlight (see wiring diagram). This YELLOW wire may be extended using 14 AWG wire.
  - ORANGE** - Connect to a +12VDC power switch (200 mA MIN./customer supplied).
3. Test the flasher for proper operation

## Flash Pattern Selection

There are 4 available flashrates for the UHFGND. These rates are determined by two jumper wires; WHITE/RED and WHITE/VIOLET. The following table defines the available flashrates.

WHT/RED	WHT/VIO	Flashrate
Intact	Intact	Modulflash
CUT	Intact	280 SF Alternating
Intact	CUT	140 DF Alternating 140 SF Simultaneous
CUT	CUT	140 DF Alternating 280 SF Alternating

**SF = Single Flash per min.**  
**DF = Double Flash per min.**