

WHELEN[®]

ENGINEERING COMPANY INC.

51 Winthrop Road
Chester, Connecticut 06412-0684
Phone: (860) 526-9504
Fax: (860) 526-4078
Internet: www.whelen.com
Sales e-mail: autosale@whelen.com
Canadian Sales e-mail: autocan@whelen.com
Customer Service e-mail: custserv@whelen.com

Installation Guide: 400 Series Lighthouse Housing 2001 Navistar

Safety First

This document provides all the necessary information to allow your Whelen product to be properly and safely installed. Before beginning the installation and/or operation of your new product, the installation technician and operator must read this manual completely. Important information is contained herein that could prevent serious injury or damage.

- **Proper installation of this product requires the installer to have a good understanding of automotive electronics, systems and procedures.**
- **If mounting this product requires drilling holes, the installer MUST be sure that no vehicle components or other vital parts could be damaged by the drilling process. Check both sides of the mounting surface before drilling begins. Also de-burr any holes and remove any metal shards or remnants. Install grommets into all wire passage holes.**
- **If this manual states that this product may be mounted with suction cups, magnets, tape or Velcro[®], clean the mounting surface with a 50/50 mix of isopropyl alcohol and water and dry thoroughly.**
- **Do not install this product or route any wires in the deployment area of your air bag. Equipment mounted or located in the air bag deployment area will damage or reduce the effectiveness of the air bag, or become a projectile that could cause serious personal injury or death. Refer to your vehicle owner's manual for the air bag deployment area. The User/Installer assumes full responsibility to determine proper mounting location, based on providing ultimate safety to all passengers inside the vehicle.**
- **For this product to operate at optimum efficiency, a good electrical connection to chassis ground must be made. The recommended procedure requires the product ground wire to be connected directly to the NEGATIVE (-) battery post.**
- **If this product uses a remote device to activate or control this product, make sure that this control is located in an area that allows both the vehicle and the control to be operated safely in any driving condition.**
- **Do not attempt to activate or control this device in a hazardous driving situation.**
- **This product contains either strobe light(s), halogen light(s), high-intensity LEDs or a combination of these lights. Do not stare directly into these lights. Momentary blindness and/or eye damage could result.**
- **Use only soap and water to clean the outer lens. Use of other chemicals could result in premature lens cracking (crazing) and discoloration. Lenses in this condition have significantly reduced effectiveness and should be replaced immediately. Inspect and operate this product regularly to confirm its proper operation and mounting condition. Do not use a pressure washer to clean this product.**
- **It is recommended that these instructions be stored in a safe place and referred to when performing maintenance and/or reinstallation of this product.**
- **FAILURE TO FOLLOW THESE SAFETY PRECAUTIONS AND INSTRUCTIONS COULD RESULT IN DAMAGE TO THE PRODUCT OR VEHICLE AND/OR SERIOUS INJURY TO YOU AND YOUR PASSENGERS!**

For warranty information regarding this product, visit www.whelen.com/warranty

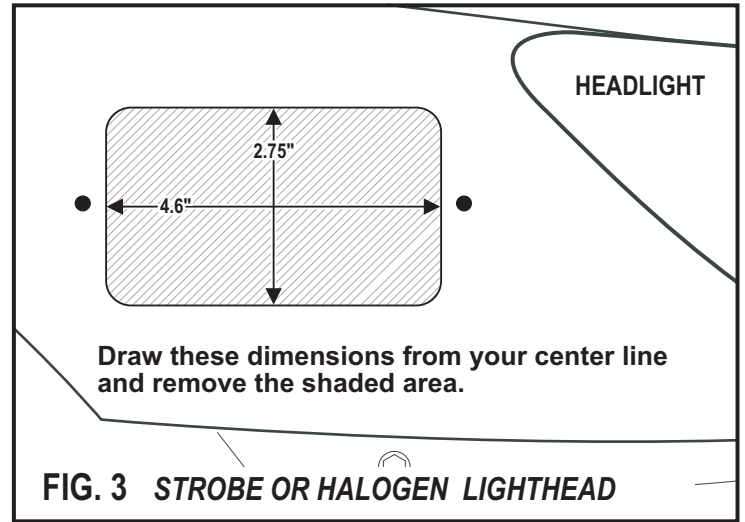
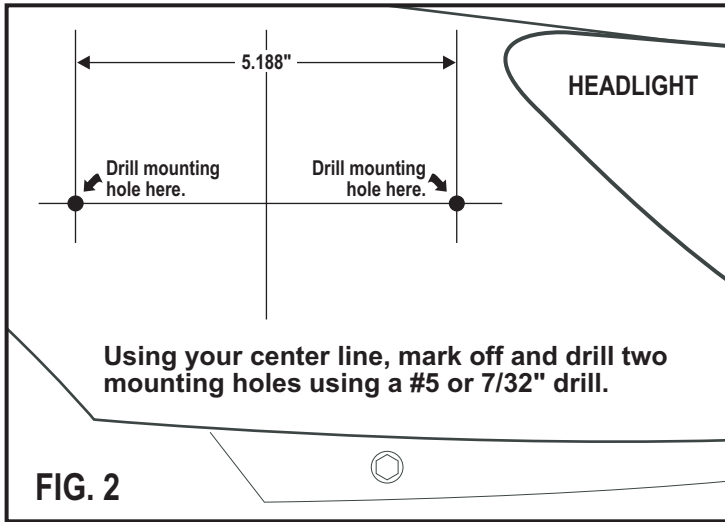
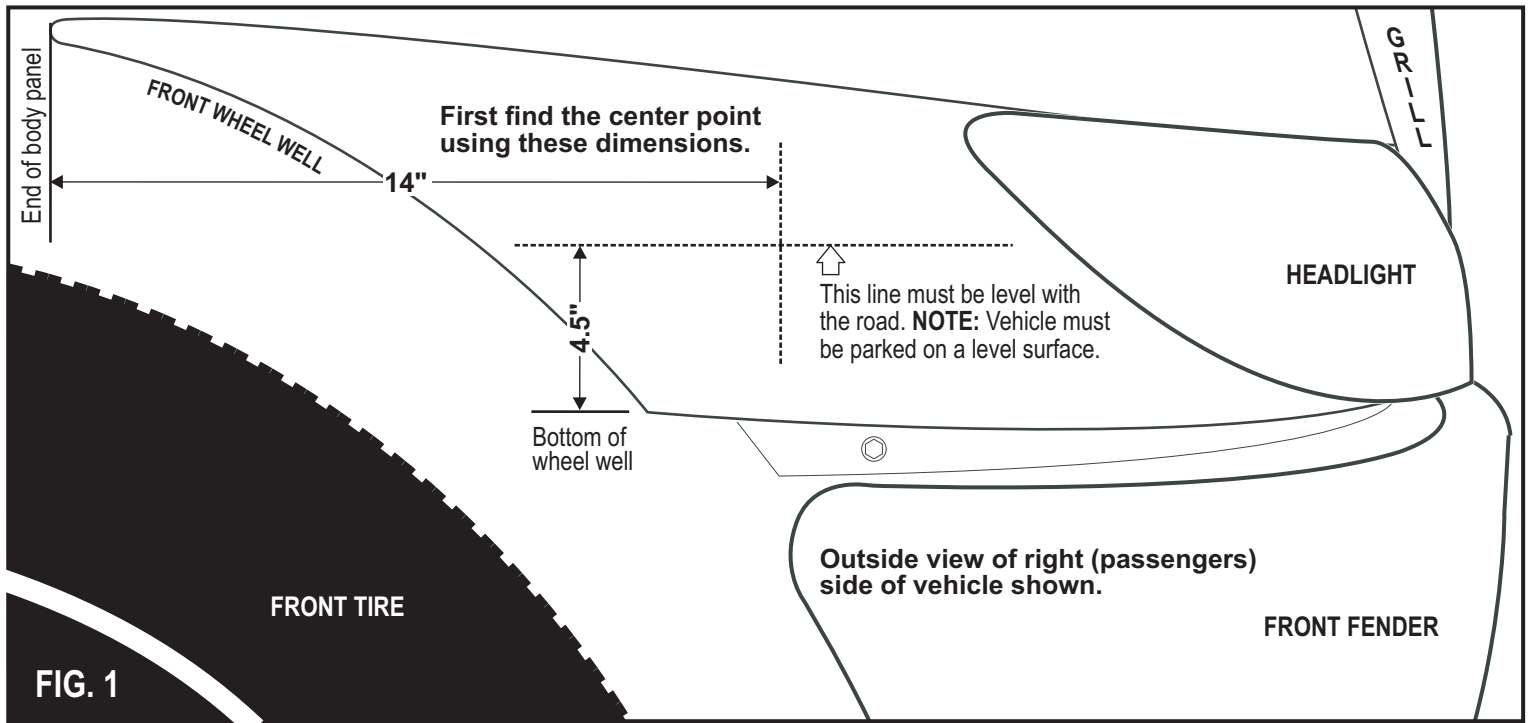

Installation:

You will need to park the vehicle on a level surface for the installation. As the diagram shows, the horizontal mounting hole line must be level with the road. Draw this line using a level.

1. Find the center line of your lighthouse using the dimensions in Figure 1. Measure from the end of the body panel and draw the vertical line. Measure from the bottom of the wheel well and, using a level, draw the horizontal line.
2. Measure and drill the 2 mounting holes (Fig. 2).
3. If you are installing a strobe or halogen lighthouse measure out from the center line and cut-out and remove the area shown in Figure 3. If you have an LED lighthouse you will just need to drill a 1" wire hole as shown in Figure 4.
4. Attach the lighthouse to the vehicle (Fig. 5). Be sure to locate the wire exit hole (in the rear casting) on the bottom and run the wires through before tightening the mounting bolts.
5. Extend the lighthouse wires to your power source.

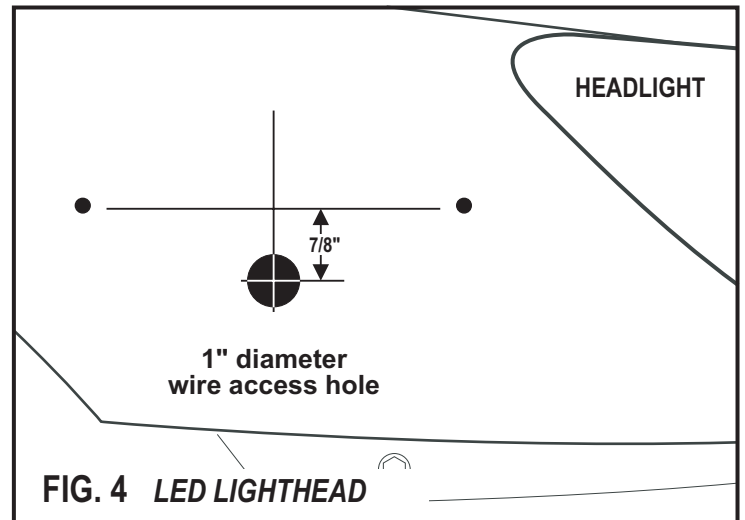

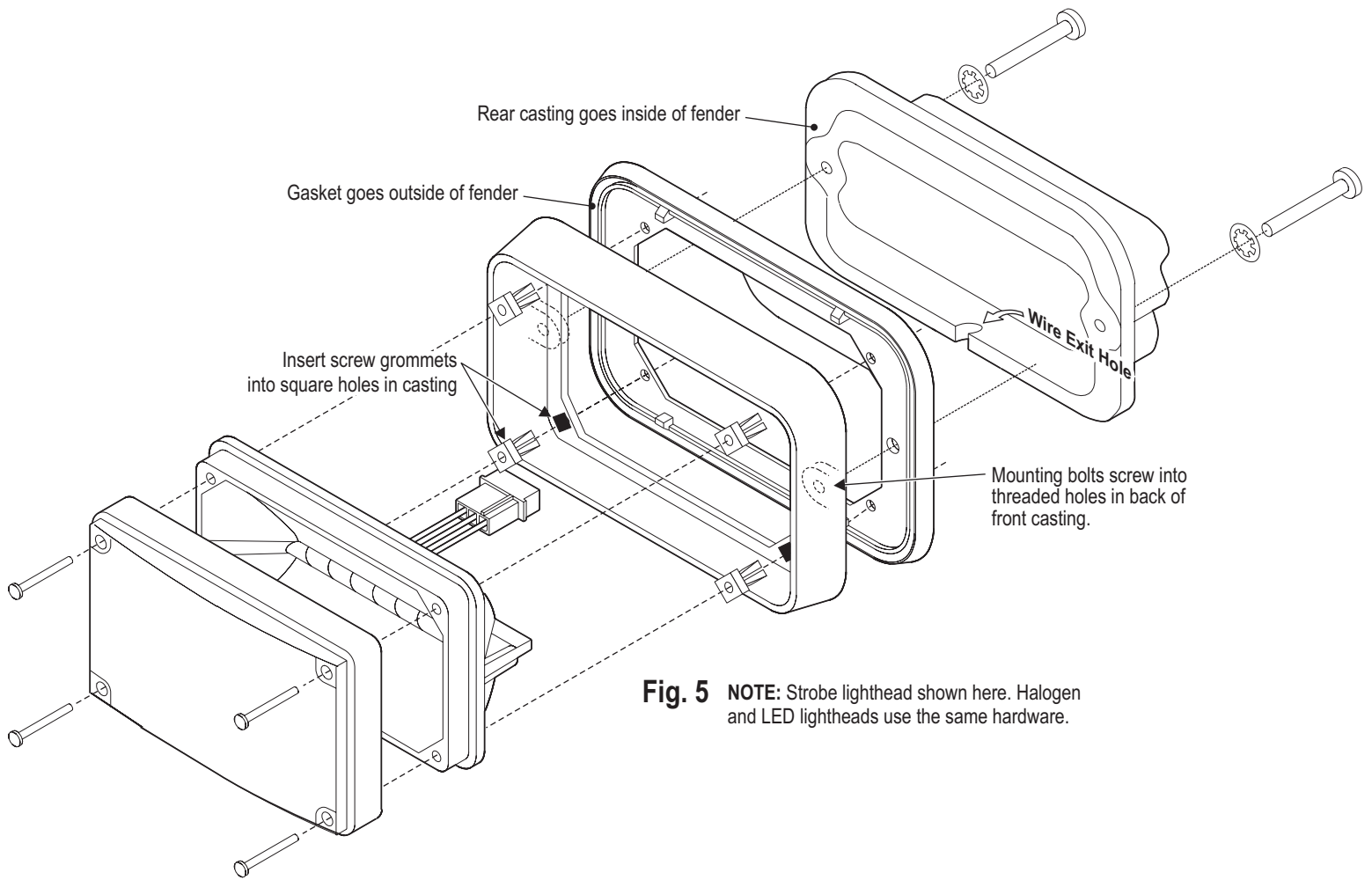

Fig. 5 NOTE: Strobe lighthead shown here. Halogen and LED lightheads use the same hardware.

**2001 NAVISTAR® 400 SERIES INTERSECTION LIGHT
RIGHT SIDE - P/N 01-0483746-R00**

QTY.	PART NUMBER	DESCRIPTION
1	11-483716-R00	RIGHT FRONT CASTING / 2001 NAV. INTERSECT.
1	11-483717-R00	RIGHT REAR COVER / 2001 NAV. INTERSECT.
4	13-062C40-16J	SCREW GROMMET / #6 FASTEX
2		SCREW / 10-24 x 2" PPHMS SS
2		WASHER #10 INT. TOOTH LOCK
1	34-0462816-00	GASKET

**2001 NAVISTAR® 400 SERIES INTERSECTION LIGHT
LEFT SIDE - P/N 01-0483746-L00**

QTY.	PART NUMBER	DESCRIPTION
1	11-483716-L00	LEFT FRONT CASTING / 2001 NAV. INTERSECT.
1	11-483717-L00	LEFT REAR COVER / 2001 NAV. INTERSECT.
4	13-062C40-16J	SCREW GROMMET / #6 FASTEX
2		SCREW / 10-24 x 2" PPHMS SS
2		WASHER / #10 INT. TOOTH LOCK
1	34-0462816-00	GASKET