

WHELEN[®]

ENGINEERING COMPANY INC.

Route 145, Winthrop Road,
Chester, Connecticut 06412
Phone: (860) 526-9504
Fax: (860) 526-4078
Internet: www.whelen.com
Sales e-mail: autosale@whelen.com
Canadian Sales e-mail: autocan@whelen.com
Customer Service e-mail: custserv@whelen.com

Installation Guide: 400-series Strobe-Halogen or Strobe-LED Lighthouse

Safety First

This document provides all the necessary information to allow your Whelen product to be properly and safely installed. Before beginning the installation and/or operation of your new product, the installation technician and operator must read this manual completely. Important information is contained herein that could prevent serious injury or damage.

- **Proper installation of this product requires the installer to have a good understanding of automotive electronics, systems and procedures.**
- **If mounting this product requires drilling holes, the installer MUST be sure that no vehicle components or other vital parts could be damaged by the drilling process. Check both sides of the mounting surface before drilling begins. Also de-burr any holes and remove any metal shards or remnants. Install grommets into all wire passage holes.**
- **If this manual states that this product may be mounted with suction cups, magnets, tape or Velcro™, clean the mounting surface with a 50/50 mix of isopropyl alcohol and water and dry thoroughly.**
- **Do not install this product or route any wires in the deployment area of your air bag. Equipment mounted or located in the air bag deployment area will damage or reduce the effectiveness of the air bag, or become a projectile that could cause serious personal injury or death. Refer to your vehicle owners manual for the air bag deployment area. The User/Installer assumes full responsibility to determine proper mounting location, based on providing ultimate safety to all passengers inside the vehicle.**
- **For this product to operate at optimum efficiency, a good electrical connection to chassis ground must be made. The recommended procedure requires the product ground wire to be connected directly to the NEGATIVE (-) battery post.**
- **If this product uses a remote device to activate or control this product, make sure that this control is located in an area that allows both the vehicle and the control to be operated safely in any driving condition.**
- **Do not attempt to activate or control this device in a hazardous driving situation.**
- **This product contains either strobe light(s), halogen light(s), high-intensity LEDs or a combination of these lights. Do not stare directly into these lights. Momentary blindness and/or eye damage could result.**
- **Use only soap and water to clean the outer lens. Use of other chemicals could result in premature lens cracking (crazing) and discoloration. Lenses in this condition have significantly reduced effectiveness and should be replaced immediately. Inspect and operate this product regularly to confirm its proper operation and mounting condition. Do not use a pressure washer to clean this product.**
- **It is recommended that these instructions be stored in a safe place and referred to when performing maintenance and/or reinstallation of this product.**
- **FAILURE TO FOLLOW THESE SAFETY PRECAUTIONS AND INSTRUCTIONS COULD RESULT IN DAMAGE TO THE PRODUCT OR VEHICLE AND/OR SERIOUS INJURY TO YOU AND YOUR PASSENGERS!**

For warranty information regarding this product, visit www.whelen.com/warranty

IMPORTANT NOTICE! This product has been designed for improved visibility. Prior to installing this product on any vehicle, check your state motor vehicle codes to confirm that this product complies with all state statutes.

Installation:

WARNING! DO NOT CONNECT the LED or HALOGEN connector to a strobe power supply!

WARNING! The LED must be connected to an electronic flasher. Allowing the LED to steady burn will damage the lighthouse and void the warranty.

WARNING! The strobe light power supply is a high voltage device. Do not touch or remove the strobe tube assembly while in operation. Wait 10 minutes after disconnecting the power source before starting any work on the power supply or system.

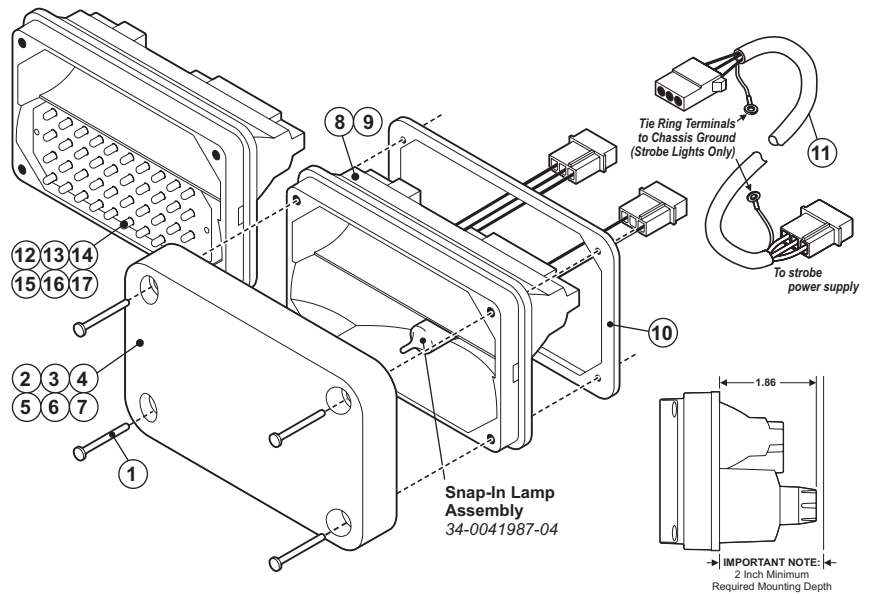

WARNING! All customer supplied wires that connect to the positive terminal of the battery must be sized to supply at least 125% of the maximum operating current and FUSED at the battery to carry that load. DO NOT USE CIRCUIT BREAKERS WITH THIS PRODUCT!

- Position the lighthouse in its mounting location. Make sure the lighthouse doesn't interfere with any existing equipment. Be aware of any items on the opposite side of the mounting surface and possible damage to existing components. Allow a 2 inch mounting depth (see above).
- Remove the lighthouse. Measure and mark off onto the mounting surface, the mounting holes and cut-out.
- Drill 4 pilot holes for a #6 sheet metal screw, than cut out and remove the area indicated in the mounting diagram.
- Extend the wires to your power source (LEDs must first be connected to a flasher). Follow the wiring below.
- Secure the assembly onto the mounting surface with the supplied sheet metal screws.

BASIC P/N	STYLE	COLOR	CABLE REQ.	STYLE:	LENS & LED COLOR:	CABLE:
01-0663479				1 = OPEN-HALOGEN 2 = STROBE-HALOGEN 3 = STROBE-LED 4 = STROBE-LED (B/T/T)	R = RED-RED B = BLUE-BLUE G = GREEN-GREEN A = AMBER-AMBER C = CLEAR-WHITE	5 = CLEAR-RED 2 = CLEAR-BLUE 4 = CLEAR-GREEN 1 = CLEAR-AMBER 0 = without CABLE 1 = with CABLE

QTY	QTY	QTY	QTY	ITEM	PART NUMBER	DESCRIPTION
		*			01-06634792 ()	MODEL 400 SERIES ASS'Y. / STROBE-HALOGEN
	*				01-06634791 ()	MODEL 400 SERIES ASS'Y. / OPEN-HALOGEN
					01-06634793 ()	MODEL 400 SERIES ASS'Y. / STROBE-LED
	*				01-06634794 R ()	MODEL 400 SERIES ASS'Y. / STROBE-LED / B-T-T
4	4	4	4	1		#6 x 1 1/2" PPHSMS
-	A/R	A/R	A/R	2	68-3183725-1S	LENS / AMBER
-	A/R	A/R	A/R	3	68-3183725-2S	LENS / BLUE
A/R	A/R	A/R	A/R	4	68-3183725-3S	LENS / CLEAR
-	A/R	A/R	A/R	5	68-3183725-4S	LENS / GREEN
A/R	A/R	A/R	A/R	6	68-3183725-5S	LENS / RED
A/R	A/R	A/R	A/R	7	02-0363485**S	LENS / SPLIT HORIZONTAL
-	-	-	1	8	02-0363172-00	ASS'Y. / REFLECTOR / STROBE-HALOGEN
-	-	1	-	9	02-0363172-01	ASS'Y. / REFLECTOR / OPEN-HALOGEN
1	1	1	1	10	38-0262867-00	GASKET
A/R	A/R	A/R	A/R	11	01-0440624-15	CABLE ASS'Y. with KIT
-	A/R	-	-	12	02-0363172-10	ASS'Y. / REFLECTOR / STROBE-LED / AMBER
-	A/R	-	-	13	02-0363172-50	ASS'Y. / REFLECTOR / STROBE-LED / RED
1	-	-	-	14	02-0363172-B0	ASS'Y. / REFLECTOR / STROBE-LED / B-T-T
-	A/R	-	-	15	02-0363172-20	ASS'Y. / REFLECTOR / STROBE-LED / BLUE
-	A/R	-	-	16	02-0363172-30	ASS'Y. / REFLECTOR / STROBE-LED / WHITE
-	A/R	-	-	17	02-0363172-40	ASS'Y. / REFLECTOR / STROBE-LED / GREEN

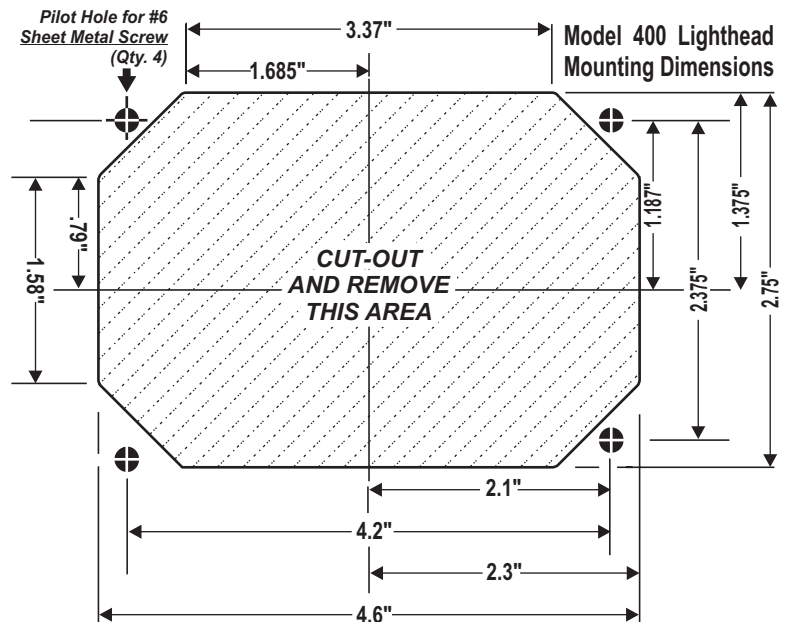

WIRING:

LED / Steady

This wire will be the +12 VDC color of the LED
BLACK-WHITE Ground

LED / B-T-T

YELLOW Brake light / +12VDC
BROWN Tail Light / +12VDC
WHITE Ground

STROBE

BLACK Cathode
RED Anode
WHITE Trigger

HALOGEN

RED +12 VDC
WHITE Ground