

WHELEN[®]

ENGINEERING COMPANY INC.

51 Winthrop Road
Chester, Connecticut 06412-0684
Phone: (860) 526-9504
Fax: (860) 526-4078
Internet: www.whelen.com
Sales e-mail: autosale@whelen.com
Canadian Sales e-mail: autocan@whelen.com
Customer Service e-mail: custserv@whelen.com

Installation Guide: Edge[®] 9M Lightbar

Safety First

This document provides all the necessary information to allow your Whelen product to be properly and safely installed. Before beginning the installation and/or operation of your new product, the installation technician and operator must read this manual completely. Important information is contained herein that could prevent serious injury or damage.

- Proper installation of this product requires the installer to have a good understanding of automotive electronics, systems and procedures.
- If mounting this product requires drilling holes, the installer **MUST** be sure that no vehicle components or other vital parts could be damaged by the drilling process. Check both sides of the mounting surface before drilling begins. Also de-burr any holes and remove any metal shards or remnants. Install grommets into all wire passage holes.
- If this manual states that this product may be mounted with suction cups, magnets, tape or Velcro[®], clean the mounting surface with a 50/50 mix of isopropyl alcohol and water and dry thoroughly.
- Do not install this product or route any wires in the deployment area of your air bag. Equipment mounted or located in the air bag deployment area will damage or reduce the effectiveness of the air bag, or become a projectile that could cause serious personal injury or death. Refer to your vehicle owner's manual for the air bag deployment area. The User/Installer assumes full responsibility to determine proper mounting location, based on providing ultimate safety to all passengers inside the vehicle.
- For this product to operate at optimum efficiency, a good electrical connection to chassis ground must be made. The recommended procedure requires the product ground wire to be connected directly to the **NEGATIVE (-)** battery post.
- If this product uses a remote device to activate or control this product, make sure that this control is located in an area that allows both the vehicle and the control to be operated safely in any driving condition.
- Do not attempt to activate or control this device in a hazardous driving situation.
- This product contains either strobe light(s), halogen light(s), high-intensity LEDs or a combination of these lights. Do not stare directly into these lights. Momentary blindness and/or eye damage could result.
- Use only soap and water to clean the outer lens. Use of other chemicals could result in premature lens cracking (crazing) and discoloration. Lenses in this condition have significantly reduced effectiveness and should be replaced immediately. Inspect and operate this product regularly to confirm its proper operation and mounting condition. Do not use a pressure washer to clean this product.
- It is recommended that these instructions be stored in a safe place and referred to when performing maintenance and/or reinstallation of this product.
- **FAILURE TO FOLLOW THESE SAFETY PRECAUTIONS AND INSTRUCTIONS COULD RESULT IN DAMAGE TO THE PRODUCT OR VEHICLE AND/OR SERIOUS INJURY TO YOU AND YOUR PASSENGERS!**

For warranty information regarding this product, visit www.whelen.com/warranty

IMPORTANT! The lightbar should be located a minimum of 16" from any radio antennas!

Permanent Mounting:

1. Locate the mounting foot and locking plate included with your lightbar. If not already present, install the locking plate onto the mounting foot. When properly positioned, this plate is centered from side to side on the mounting foot.
2. Flip the lightbar upside-down to expose the bottom of the extrusion and place the mounting foot onto the extrusion.
3. Rotate the mounting foot 90° in a counter-clockwise direction. Make sure that the edges of the mounting foot swing into position under the extrusion mounting lip.
4. Repeat this procedure for the remaining mounting foot and return the lightbar to its right side-up position.
5. Position the lightbar onto the vehicle roof in the desired mounting location. One often selected location is directly above the B-pillars. This area is the strongest part of the roof. Refer to your lightbar manual for cable exit location, to be sure that the lightbar is facing the proper direction.
6. Adjust the two mounting feet outwards so that they are as close to the edge of the roof as possible. Make sure that both mounting feet are in full contact with the roof. Be sure that there is no less than 1/2" clearance between the roof and the lightbar at their closest point. When the mounting feet are in their proper position, lightly tighten the locking plate allen head set screws.
7. Turn the lightbar upside down and firmly tighten all of the set screws from step 6 (2 or 4 per side).
8. On the adjustable foot, use the hole in the pad as a guide to drill the two holes into the mounting foot at the locations shown.

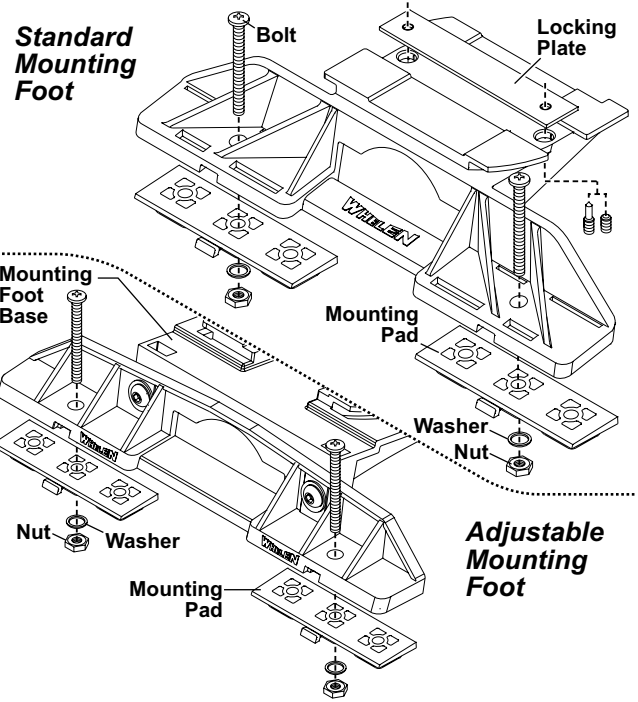

9. Place the lightbar in its final mounting position on the vehicle, mark the mounting hole locations off onto the mounting surface, remove the lightbar and drill the mounting holes.
10. Place the lightbar back onto the vehicle lined up with the mounting holes and secure the mounting feet to the vehicle with the supplied hardware.

Strap Mounting:

1. Locate the mounting foot, anchor plate and locking plate included with your lightbar. If not already present, install the locking plate onto the mounting foot. When properly positioned, this plate is centered from side-to-side on the mounting foot.
2. Flip the lightbar upside-down to expose the bottom of the extrusion and place the mounting foot onto the extrusion.
3. Rotate the mounting foot 90° in a counter-clockwise direction. Make sure that the edges of the mounting foot swing into position under the extrusion mounting lip. Install an anchor plate onto the extrusion in the same manner.
4. Repeat this procedure for the remaining mounting foot and anchor plate and return the lightbar to its right side-up position.
5. Position the lightbar onto the vehicle roof in the desired mounting location. One often selected location is directly above the B-pillars. This area is the

strongest part of the roof. Refer to your lightbar manual for cable exit location, to be sure that the lightbar is facing the proper direction.

6. Adjust the two mounting feet outwards so that they are as close to the edge of the roof as possible. Both mounting feet must be in full contact with the roof. Be sure that there is no less than 1/2" clearance between roof and lightbar at their closest point. When the mounting feet are in their proper position, lightly tighten the locking plate allen head set screws.
7. Return the lightbar to an upside-down position. Slide each anchor plate outwards until it is fully engaged with its corresponding mounting foot. With the mounting feet and anchor plates in their proper positions firmly tighten all of the set screws (2 or 4 per side). Flip the lightbar right side-up and return it to its mounting position.
8. Open both drivers side doors. In the area directly below the mounting foot, pull the weatherstrip away from the vehicle so the area where the mounting strap will be secured is exposed. Repeat for the other side.
9. Insert the mounting strap through the mounting foot. Be sure that the strap fits flush against the area where it will be secured onto the vehicle.

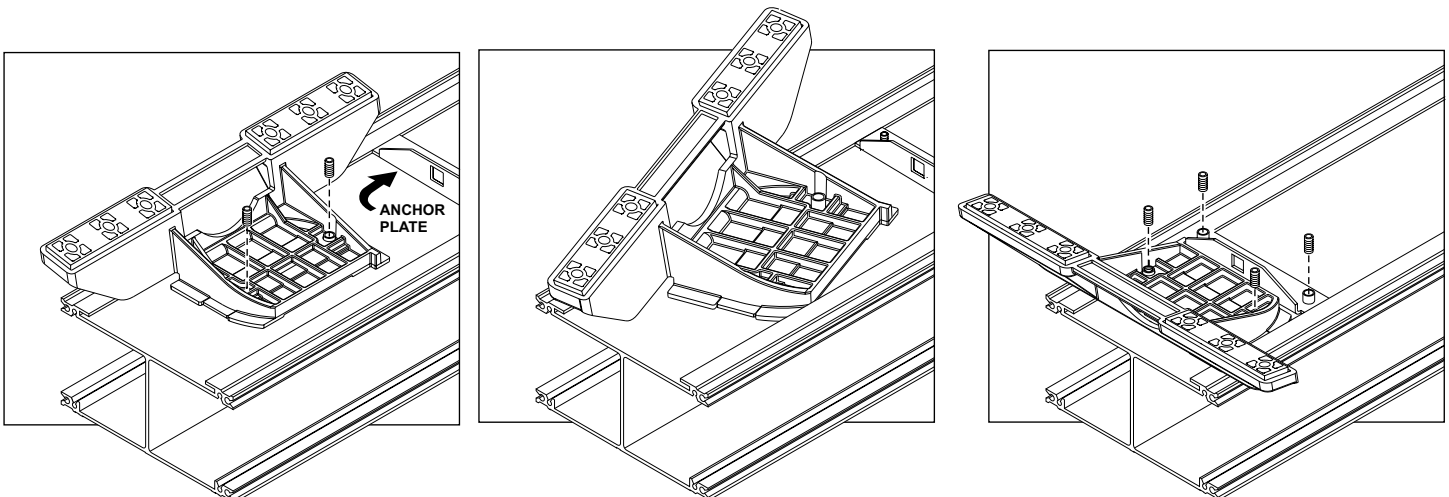

Insert the tension bolt through the mounting strap and anchor plate, into the tinnerman nut. Tighten slightly with a long-shafted, Phillips screwdriver. Repeat procedure for passenger side.

10. If your mounting strap has mounting holes in the end of the strap, use these holes as a template to drill appropriately sized pilot holes through the strap and into the vehicle. Repeat for passenger side of the vehicle.
11. Firmly tighten the tension bolts to secure the lightbar to the vehicle.

NOTE: Model MKAJ is an adjustable mounting foot. On this model you may loosen the screws on the rear of the foot and adjust the angle of the lightbar. This feature can be used if the angle of the roof is not level with the road. IMPORTANT: To adjust the leveling screws you must use a torque wrench set at 35 to 40in./lbs.

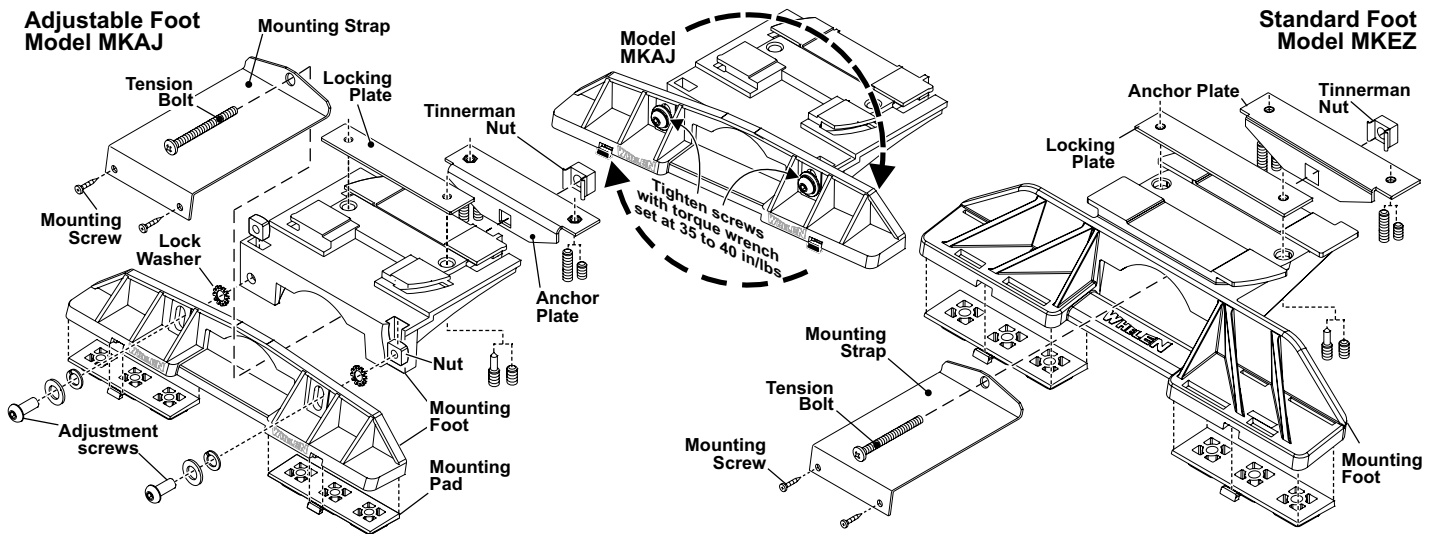

5" Mounting Foot

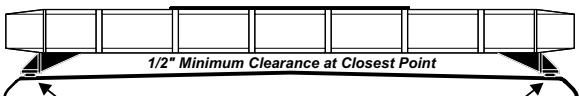
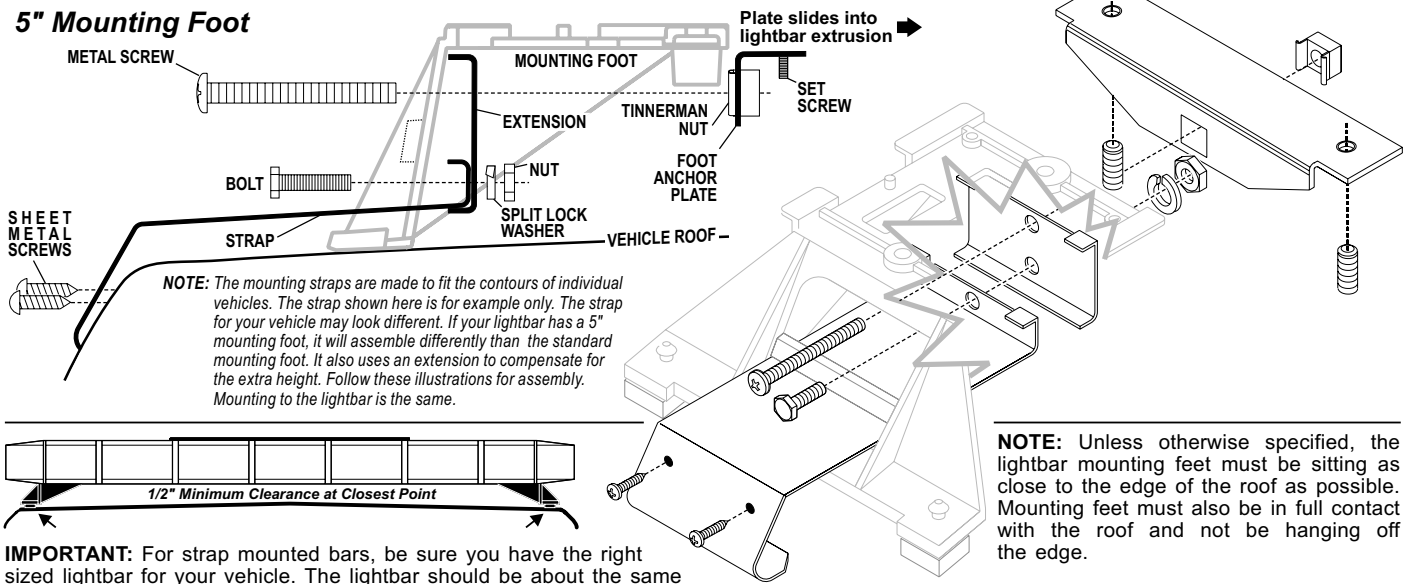

IMPORTANT: For strap mounted bars, be sure you have the right sized lightbar for your vehicle. The lightbar should be about the same width as the vehicle roof. If the lightbar is too large or small it will not mount properly to the vehicle and may shift or come loose during driving.

Routing your Edge® Lightbar Cable(s)

1. To protect the headliner from damage caused by drilling the cable access hole through the vehicle roof, allow a 5" to 7" distance between roof and headliner by lowering the headliner before drilling.
2. Using a 1" hole saw, drill the cable access hole.

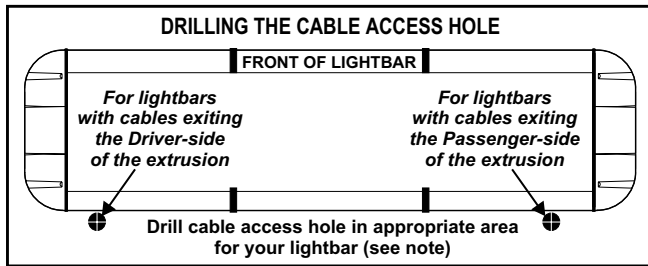

NOTE: There may be a roof support member that spans the distance between the driver's and passenger's side. **DO NOT DRILL THROUGH THIS MEMBER!** Adjust the location until the hole can be drilled without contacting this support member.

3. Use a round file to smooth and de-burr the edges of the hole.
4. Insert a 1" grommet (user supplied) into the cable access hole.
5. Insert the cable(s) through the cable access hole into the vehicle. Use RTV silicone to weatherproof the access hole after the cable(s) are pulled completely into the vehicle.
6. Route the cable(s) one at a time to their respective destinations (power cable to vehicle battery; control cable to customer switch panel). It is left to the installation technician's discretion to select a path for these cables that will both protect the cables from possible damage and not interfere with the operation of any other vehicle components or equipment. Refer to the instructions included with your switches for switch wiring information.

NOTE: The outer surfaces of this product may be cleaned with mild soap and water. Use of any other chemicals may void product warranty. Do not use a pressure washer.

Connecting the Cables

WARNING! All customer supplied wires that connect to the positive terminal of the battery must be sized to supply at least 125% of the maximum operating current and **FUSED** at the battery to carry that load. **DO NOT USE CIRCUIT BREAKERS WITH THIS PRODUCT!**

Power Cable:

1. Follow the factory wiring harness through the firewall. It may be necessary to drill a hole in the firewall. If so, be absolutely sure that there are no components that could be damaged by drilling. After the hole has been drilled, insert a grommet to protect the cable.

2. Route the cable along the factory wiring harness towards the battery. Install a 40 amp fuse block (customer supplied) on the end of the RED wire in the power cable. Remove the fuse from the fuse block before connecting any wires to the battery.
3. Connect the fuse block to the POSITIVE (+) terminal on the battery. There can not be more than two (2) feet of wire between the fuse block and the battery. The wire between the fuse block and the battery is "unprotected", do not allow this wire to come into contact with any other wires.
4. Connect the BLACK wire to the factory chassis ground adjacent to the battery.

Control Cable:

Extend the control cable to your switch panel and make the appropriate connections, using the information provided on pages 4 or 5, depending on which lightbar you have. When you apply +12 VDC to a Control Cable wire, you activate its function. The control cable connects to your control head or switch box and is fused there. Typical fusing is 5 Amps.

LowPower / VIOLET :

The type of switch used is dependant on how the operator wishes the Hi/Low feature to function:

Latching Mode: By applying +12 VDC voltage to the Violet wire for less than 1 sec., the power supply is "latched" into low power operation. The unit must be turned off and then back on to restore normal, Hi power operation. (A Momentary Switch is Preferred)

Level Mode: Applying +12 VDC voltage to the Violet wire for more than 1 sec. holds the power supply in low power mode until voltage is removed. (A Toggle Switch is Preferred)

NOTE: The wire functions listed in this manual are the factory default settings for a fully loaded lightbar. To find the correct wire functions for the lightbar you ordered, refer to the switch operations sheet included with your lightbar.

Troubleshooting:

Your lightbar should now be fully operational. If your lightbar is not functioning properly, check the following:

- The positive wire (RED) is properly connected to the battery, by way of the user supplied fuse block.
- A working fuse of the correct amperage (40 amp) is installed in the fuse block.
- The ground wire (BLACK) is properly connected to the factory ground.

If these connections are good, contact your Whelen representative for further assistance.

Changing Flash Patterns Without a Scan-Lock™ Cable:

The 9M lightbar is capable of displaying a variety of flash patterns. These patterns can be changed using one of two methods. The first is through the optional Scan-Lock™ pattern cable. This allows you to change patterns from within the vehicle and is preferred by customers who want to be able to easily change their flash patterns if need arises. For users who rarely or infrequently change patterns and do not require a Scan-Lock cable, you must partially disassemble the lightbar and change patterns manually.

WARNING: The strobe light power supply is a high voltage device. Do not remove strobe tubes or dismantle strobe light head assemblies in the system while it is in operation. Wait 10 minutes after turning off power before starting work or any trouble shooting.

WARNING! THIS PROCEDURE REQUIRES THE LIGHTBAR TO BE ACTIVE WHILE IN A PARTIALLY DISASSEMBLED STATE. DO NOT TOUCH ANY LIGHTBAR COMPONENTS EXCEPT FOR THOSE REFERENCED IN THIS PROCEDURE.

1. Notice where the cable enters the bottom of the extrusion. If it enters on the driver side, the Power Distribution Board will face the rear of the vehicle. If it enters on the passenger side, it will be facing the front of the vehicle.
2. Remove the endcap nearest to the cable entry. On the appropriate side (front or rear) of the lightbar, remove lenses and move lighthoods away from the extrusion until clear access to the Power Distribution Board has been gained. **Be sure to record the exact position of each component to ensure proper re-assembly.**
3. **Changing Strobe Lighthouse Patterns** - Locate the 3-position connector. Each of the 3 sockets control pattern selection for each of the lightbar's 3 strobe power supplies (PS:A, PS:B and PS:C). In the default configuration, the corner strobes use PS: A, the inboard strobes use PS: B and the end strobes use PS: C. Activate the strobe lights that are to receive the new flash pattern. Momentarily applying +12VDC to the appropriate socket will cycle that power supply's current flash pattern to the next flash pattern. Repeat this procedure until the desired pattern is displayed. Allowing this pattern to flash for a minimum of 5 seconds will make this pattern the default pattern.
4. **Changing Halogen Lighthouse Patterns** - Locate the 4-position connector on the appropriate halogen flasher (A or B). The socket located in position 4 controls pattern selection for the halogen lighthoods connected to that flasher. Momentarily applying +12VDC to this socket will cycle that halogen flasher's current flash pattern to the next one. Repeat this procedure until the desired pattern is displayed. Allowing this pattern to flash for a minimum of 5 seconds will make this pattern the default pattern.

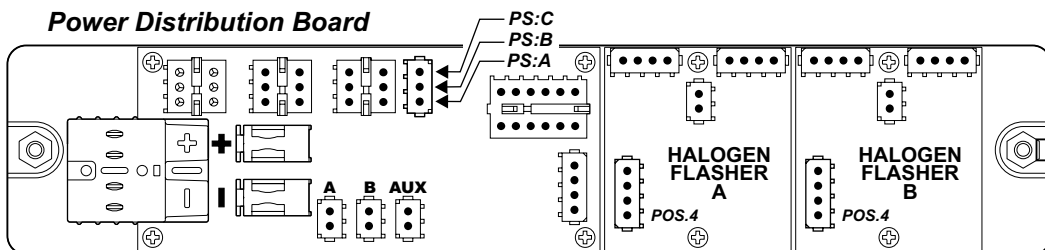

Restoring the Factory Default Pattern

To restore the factory default flash pattern, make sure that the lighthoods to be restored are off. For strobe lighthoods, apply +12VDC to the appropriate socket (see strobe lighthouse procedure above) while powering up the corresponding lighthoods. Allow pattern to be displayed for a minimum of 5 seconds to make this the default pattern.

For halogen lighthoods, use the same procedure as outlined for strobe lighthoods, substituting the halogen selection socket(s) where the strobe socket is referenced.

Mounting Lighthoods to Extrusion

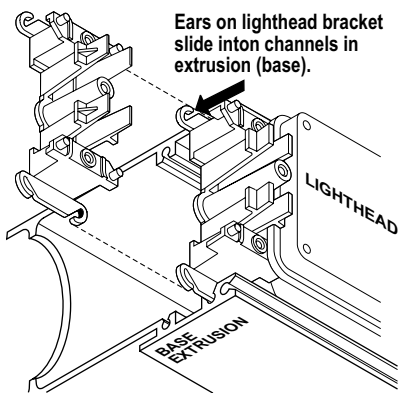

Lighthouse mounting holes snap into the raised bosses on the lighthouse bracket.

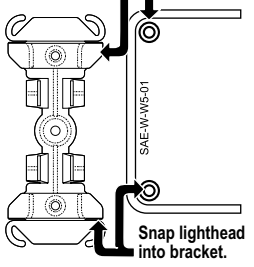

Installing a Corner Strobe

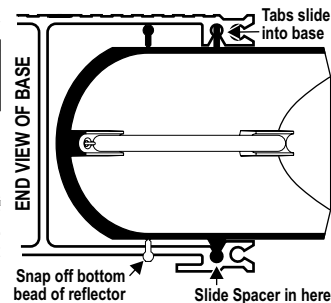
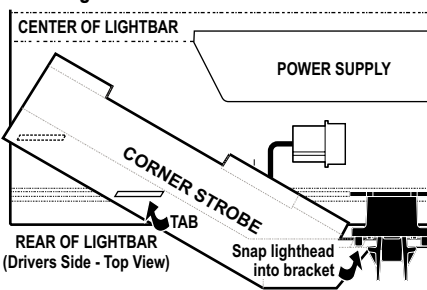

Before working on your strobe lights, disconnect the lightbar from power and remove the endcap. **WARNING: The strobe light power supply is a high voltage device. Do not remove the strobe tubes or dismantle the strobe lighthoods in the system while the unit is in operation. Wait 10 minutes after turning off power before working on the system.** To remove the lighthouse, unplug it from the mounting bracket, unplug it, and slide it out of the side of the lightbar base. If you are replacing the lighthouse, snap off the bottom bead on the new lighthouse as shown. Plug the new lighthouse into the lightbar, slide it into the base and snap it into the mounting bracket.

Endcap, Gasket, Lens & Spacer Installation

Remove the 4 screws (A) that hold the endcap (B) on and pull the endcap and gasket (C) off. Slide lenses (D) out of the lightbar, to gain access to the extrusion. When reinstalling the lenses and spacers, install the cord seal (NFPA). When reinstalling the endcap, place the endcap gasket into its position on the endcap and line up all the tabs and holes. Spacers (not shown) mount the same as lenses.

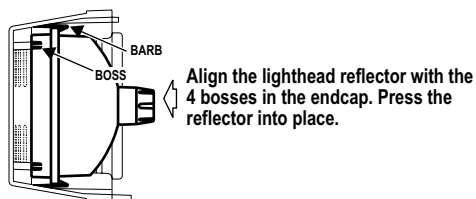
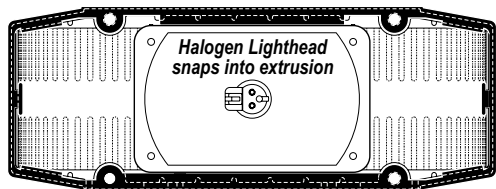

Seal Cord Installation / NFPA Only:

- 1 - Cut the seal cord approx. 1-1/2" longer than the extrusion on each side.
- 2 - Rub silicone over the cord seal leaving 3 to 4 inches on one end dry.
- 3 - Beginning with 1 corner lens, start the lens into the bottom lens track. Place the cord seal onto the groove in the top of the lens. Leave 1 to 2 inches free.
- 4 - Hold onto the left end of the seal hanging out and slide the corner lens into position.
- 5 - From the opposite end of the lightbar, pull the seal cord tight and install the remaining lenses and divider.

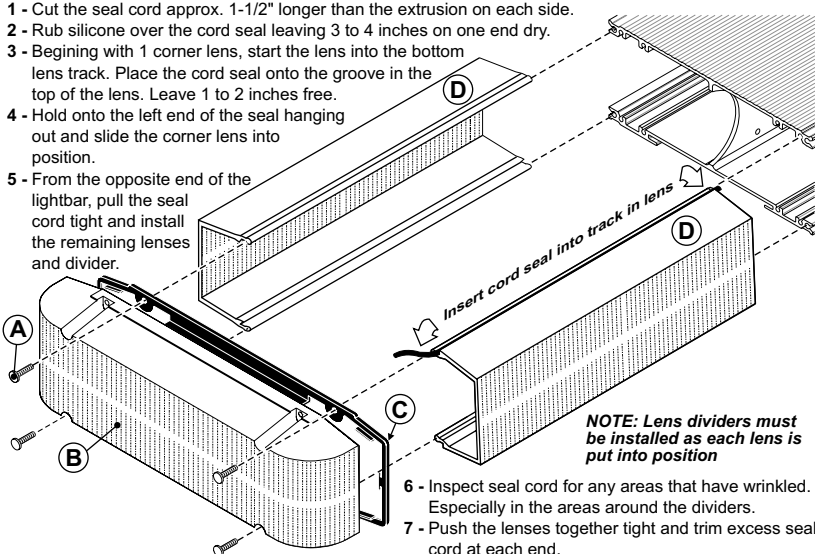

- 6 - Inspect seal cord for any areas that have wrinkled. Especially in the areas around the dividers.
- 7 - Push the lenses together tight and trim excess seal cord at each end.

EDGE® 9M SERIES LIGHTBAR for MODELS EQUIPPED with STROBE TRAFFIC ADVISOR™

MAIN FUSE CHART

To use the chart below: After determining which function wires you will use, add up the amp rating of each function wire. You must then multiply this by 1.25 (see warning) and fuse the RED power wire at this rating.

WIRE	FUNCTION	CURRENT DRAW
GRN	Front Corner Strobes	3 amps
BLU	Rear Corner Strobes	3 amps
GRN/WHT TRACE	Front Inboard Strobes	3 amps
BLU/WHT TRACE	Rear Inboard Strobes	3 amps
WHT/GRN TRACE	T.A. / 2 Strobe Flash	3 amps
WHT/BLU	T.A. / 4 Strobe Flash	6 amps
YEL	Passenger Alley Light	2.5 amps
WHT	Driver Alley Light	2.5 amps
WHT/BLK	Take-Down Lights	5 amps
WHT/BRN	Flasher "A"	5 amps
GRN/BLK	Right Traffic Advisor	6 amps
WHT/ORG	Auxiliary Option	5 amps
WHT/YEL	Flashing Take-Downs	2.5 amps
BLU/BLK	Left Traffic Advisor	6 amps

EXAMPLE: Using the WHITE/BLACK, WHITE, & WHITE/ ORANGE function wires, the total amp draw is 17.5 amps. Multiply this by 1.25 which comes out to 21.87 amps. You must fuse the RED power wire at 25 amps.

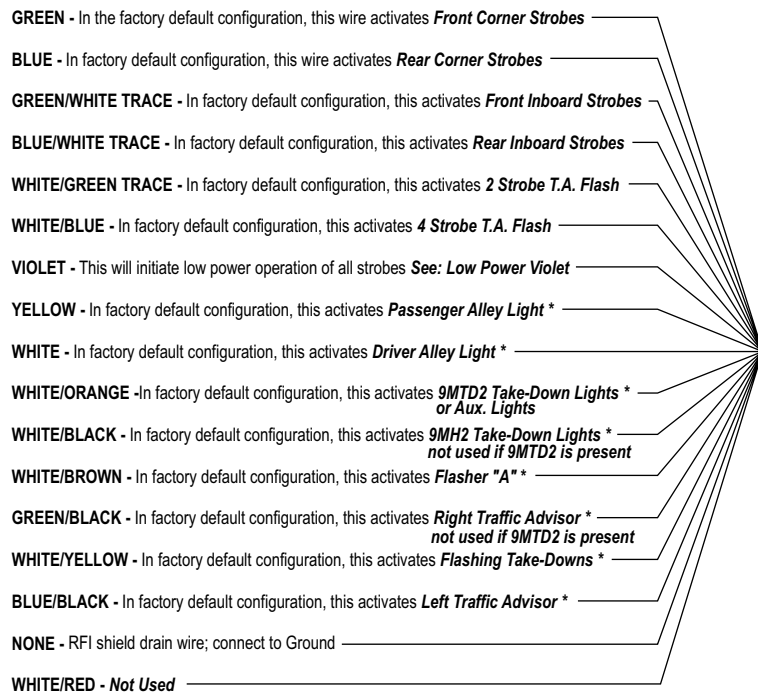

See Main Fuse Chart for fuse value * = Optional Equipment: May not be present on all Lightbars

- RED - +12 VDC/8 AWG
- BLACK - Ground/8 AWG
- NONE - RFI Shield Drain

EDGE® 9M SERIES LIGHTBAR

MAIN FUSE CHART

To use the chart below: After determining which function wires you will use, add up the amp rating of each function wire. You must then multiply this by 1.25 (see warning) and fuse the RED power wire at this rating.

WIRE	FUNCTION	CURRENT DRAW
GRN	Front Corner Strobes	3 amps
BLU	Rear Corner Strobes	3 amps
GRN/WHT TRACE	Front Inboard Strobes	3 amps
BLU/WHT TRACE	Rear Inboard Strobes	3 amps
GRN/BLK	Front Outboard Strobe	3 amps
BLU/BLK	Rear Outboard Strobe	3 amps
YEL	Passenger Alley Light	2.5 amps
WHT	Driver Alley Light	2.5 amps
WHT/BLK	Take-Down Lights	5 amps
WHT/BRN	Flasher "A"	5 amps
WHT/GRN	Flashers "B"	5 amps
WHT/ORG	Auxiliary Option	5 amps
WHT/YEL	Flashing Take-Downs	2.5 amps
WHT/BLU	Work Lights	5 amps
WHT/VIO	Flashing Work Lights	2.5 amps

EXAMPLE: Using the WHITE/BLACK, WHITE, & WHITE/ ORANGE function wires, the total amp draw is 17.5 amps. Multiply this by 1.25 which comes out to 21.87 amps. You must fuse the RED power wire at 25 amps.

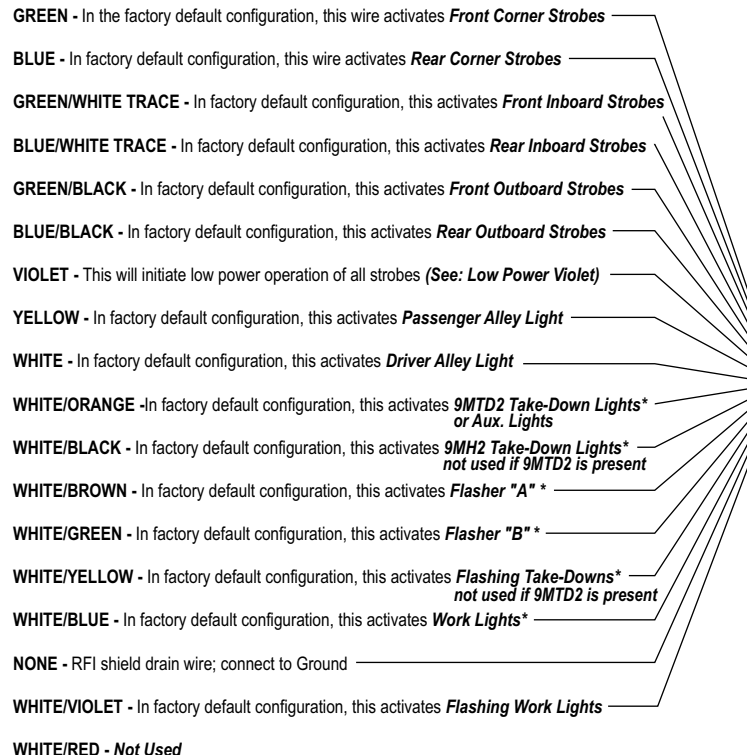

See Main Fuse Chart for fuse value * = Optional Equipment: May not be present on all Lightbars

- RED - +12 VDC/8 AWG
- BLACK - Ground/8 AWG
- NONE - RFI Shield Drain