

WHELEN[®]

ENGINEERING COMPANY INC.

51 Winthrop Road
Chester, Connecticut 06412-0684
Phone: (860) 526-9504
Fax: (860) 526-4078
Internet: www.whelen.com
Sales e-mail: autosale@whelen.com
Canadian Sales e-mail: autocan@whelen.com
Customer Service e-mail: custserv@whelen.com

Installation Manual: 400 Series Strobe Lighthouse

Safety First

This document provides all the necessary information to allow your Whelen product to be properly and safely installed. Before beginning the installation and/or operation of your new product, the installation technician and operator must read this manual completely. Important information is contained herein that could prevent serious injury or damage.

- **Proper installation of this product requires the installer to have a good understanding of automotive electronics, systems and procedures.**
- **If mounting this product requires drilling holes, the installer MUST be sure that no vehicle components or other vital parts could be damaged by the drilling process. Check both sides of the mounting surface before drilling begins. Also de-burr any holes and remove any metal shards or remnants. Install grommets into all wire passage holes.**
- **If this manual states that this product may be mounted with suction cups, magnets, tape or Velcro[®], clean the mounting surface with a 50/50 mix of isopropyl alcohol and water and dry thoroughly.**
- **Do not install this product or route any wires in the deployment area of your air bag. Equipment mounted or located in the air bag deployment area will damage or reduce the effectiveness of the air bag, or become a projectile that could cause serious personal injury or death. Refer to your vehicle owner's manual for the air bag deployment area. The User/Installer assumes full responsibility to determine proper mounting location, based on providing ultimate safety to all passengers inside the vehicle.**
- **For this product to operate at optimum efficiency, a good electrical connection to chassis ground must be made. The recommended procedure requires the product ground wire to be connected directly to the NEGATIVE (-) battery post.**
- **If this product uses a remote device to activate or control this product, make sure that this control is located in an area that allows both the vehicle and the control to be operated safely in any driving condition.**
- **Do not attempt to activate or control this device in a hazardous driving situation.**
- **This product contains either strobe light(s), halogen light(s), high-intensity LEDs or a combination of these lights. Do not stare directly into these lights. Momentary blindness and/or eye damage could result.**
- **Use only soap and water to clean the outer lens. Use of other chemicals could result in premature lens cracking (crazing) and discoloration. Lenses in this condition have significantly reduced effectiveness and should be replaced immediately. Inspect and operate this product regularly to confirm its proper operation and mounting condition. Do not use a pressure washer to clean this product.**
- **It is recommended that these instructions be stored in a safe place and referred to when performing maintenance and/or reinstallation of this product.**
- **FAILURE TO FOLLOW THESE SAFETY PRECAUTIONS AND INSTRUCTIONS COULD RESULT IN DAMAGE TO THE PRODUCT OR VEHICLE AND/OR SERIOUS INJURY TO YOU AND YOUR PASSENGERS!**

For warranty information regarding this product, visit www.whelen.com/warranty

Installation:

WARNING! The strobe light power supply is a high voltage device. Do not touch or remove the strobe tube assembly while in operation. Wait 10 minutes after disconnecting the power source before starting any work on the power supply or system.

WARNING! All customer supplied wires that connect to the positive terminal of the battery must be sized to supply at least 125% of the maximum operating current and **FUSED** at the battery to carry that load. **DO NOT USE CIRCUIT BREAKERS WITH THIS PRODUCT!**

1. Position the lighthouse in its approximate mounting location. Make sure that the lighthouse will not interfere with any existing equipment. Also, be aware of any and all items on the opposite side of the mounting surface to prevent any possible damage to existing components.
2. Remove the lighthouse. Measure and mark off onto the mounting surface, the mounting holes and cut-out as shown.
3. Using an appropriately sized drill bit, drill the pilot holes.
4. Cut out and remove the area indicated in the mounting diagram.
5. Route the cable assembly towards the strobe power supply. Be sure that both ring terminals are grounded to the vehicle chassis ground.
6. Plug the lighthouse into the cable and plug the cable into the strobe power supply. Test operation of the lighthouse before securing it to the vehicle.
7. Secure the assembly onto the mounting surface with the supplied sheet metal screws.

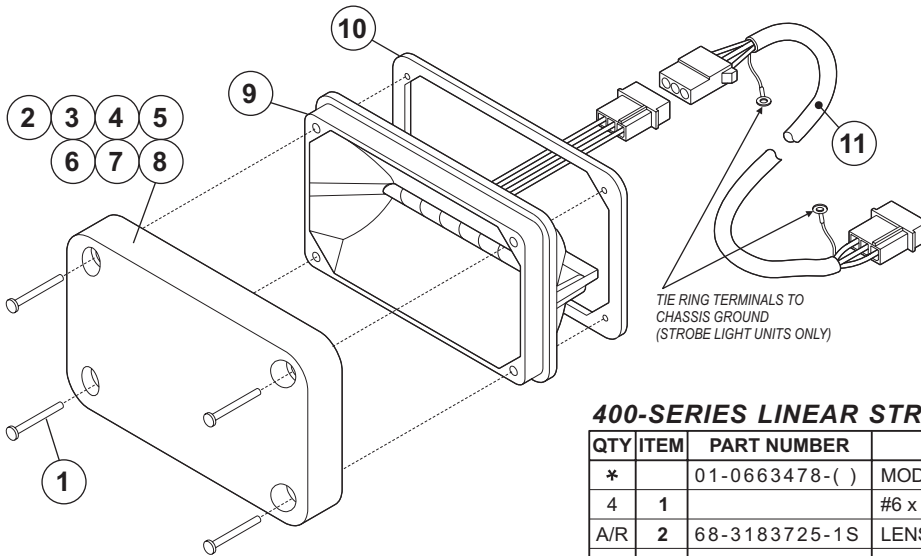

BASIC P/N **COLOR** **CABLE REQ.**

01-0663478-

COLOR:

R = RED C = CLEAR

B = BLUE * = SPLIT

G = GREEN 5 = "E" SPEC

A = AMBER RED

CABLE:

0 = without CABLE

1 = with CABLE

400-SERIES LINEAR STROBE LIGHTHEAD

QTY	ITEM	PART NUMBER	DESCRIPTION
*		01-0663478-()	MODEL 400 SERIES ASSEMBLY / LINEAR STROBE
4	1		#6 x 1 1/2" PHILLIPS PAN HEAD SMS
A/R	2	68-3183725-1S	LENS / AMBER
A/R	3	68-3183725-2S	LENS / BLUE
A/R	4	68-3183725-3S	LENS / CLEAR
A/R	5	68-3183725-4S	LENS / GREEN
A/R	6	68-3183725-5S	LENS / RED
A/R	7	68-3183725E5S	LENS / KKKE-SPEC RED
A/R	8	02-0363484**S	ASSEMBLY / SPLIT LENS
1	9	02-0362824-00	REFLECTOR ASSEMBLY / LINEAR
1	10	38-0262867-00	GASKET
A/R	11	01-0440624-15	CABLE ASSEMBLY with KIT

SPECIFICATIONS

VOLTAGE ANODE = 225 VDC (MIN.)

VOLTAGE TRIGGER = 150 VDC (MIN.)

